

**Important Information for Customers Using Fuji Square Pilot Light DP series
(A part of LED lights of CR partial pressure with working voltage 200-220VAC)**

We greatly appreciate your patronage for our products. Lately, we have found a failure of the Square Pilot Light DP series manufactured during a certain period of time; LED unit's lighting lifetime may decrease.

Models that apply to the descriptions both (1) and (2) below are concerned. Namely, they are part of LED lights of CR partial pressure with working voltage 200-220VAC. They will not lead to collateral effects such as fire and smoke.

We will inform customers of this important information through sales channel and **supply a replacement product of LED unit without charge** to customers using the concerned model(s). If your models apply to the descriptions below, please contact our sales personnel, specified agent, or distributor.

(1) [Concerned Models]

The following LED lights of CR partial pressure with working voltage 200-220VAC:

1. Square Pilot Light

Model number: DP36xxx-xM3, DP40xxx-xM3, and DP48xxx-xM3

2. LED unit (Replacement LED light of Square Pilot Light)

Reference: DN6Q001-2Mx and DN6Q001-3Mx

(2) [Concerned Lot (Manufactured Date)]

Manufactured between April 1st 2008 and November 24th 2009.

Please refer to the step 3 in the attachment 1 "Method of Replacing DP Square Pilot Light LED Unit" to check if your models fall under concerned models.

[For replacing LED unit]

From the standpoint of lifetime, this product can be easily replaced from the front face and be continuously used by changing LED unit. Please refer to the attachment 1 "Method of Replacing DP Square Pilot Light LED Unit" for how to replace LED unit as well as "Operation Display Device" catalogue.

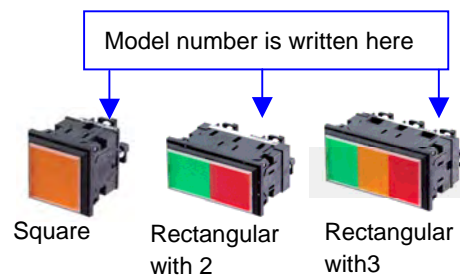

[Contact]

If you use the concerned model(s), please contact our sales personnel, specified agent, or distributor. If you are not sure whether or not your product is concerned or whom you should contact, please contact below:

Fuji Electric FA Components & Systems Co., Ltd Contact person: Inoue

E-mail: fukiage-cemadoguti@fujielectric.co.jp

Hours: 9:00am-5:00pm (except Sat, Sun, holidays, New-year holidays)

Your personal information (name, address, phone number, etc.) is intended to be used only for the subject matter and will be strictly controlled. Although we may disclose your personal information only within a required range in consigning part of our business to our business partner or a group company, we will responsibly supervise the handling of your personal information in the relevant business partner or group company.

Method of Replacing DP Square Pilot Light LED Unit

- ⚠ Warning** 1. This instruction shows how to replace the units. Please read this instruction and the safety precautions for handling the product in the catalogue before actual work.
- ⚠ Warning** 2. It can be replaced from the front face of the panel board without disconnecting; however, please note the following.
 - 2-1. Do not insert your finger(s) inside while removing LED unit. Though electrodes are at the farthest, touching on them may result in an electric shock.
- ⚠ Note** 2-2. We recommend that the panel board be closed during the work to prevent things from dropping.
- 3. We supply the inspected replacement without charge and guarantee its operation; therefore, it doesn't need to be checked at your site. However, we would ask you to perform lighting check with the test button for the important places where light test circuit etc are located.
- 4. Removed units need not to be returned to us. However if you would like to do so, please contact our sales personnel or the contact person shown on our website. We will inform you where to send.

Step 1. Tools

Use a flat-blade screwdriver.

Prepare one as shown in the illustration.

Illustration 1. A flat-blade screwdriver's size

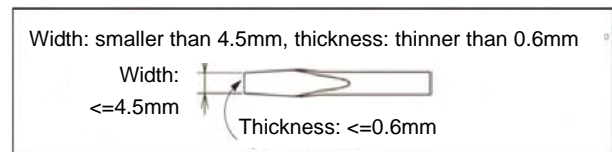

Step 2. Removing LED Unit

2.1 It can be removed from the front face of the panel board.

*No need to open the panel board.



2.2 Grooves can be seen. The picture is a rectangular type.

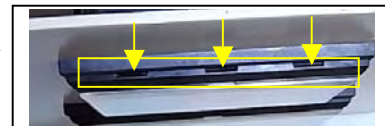

[Position of grooves]

Grooves are located as shown in the illustration.

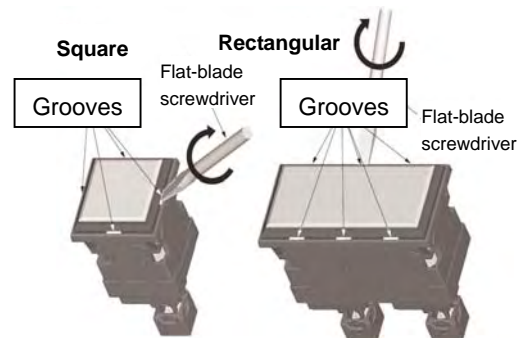

2.3 Insert the tip of the screwdriver into one of the grooves.

⚠ Note

Hold the product with your finger.

The product might fall when removing.

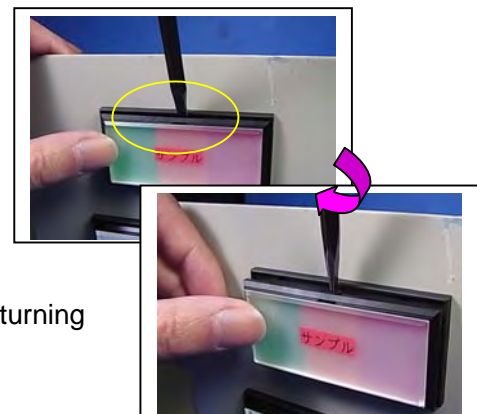

2.4 Pilot light (where LED unit is located) can be removed by turning the screwdriver.

2.5 Remove the pilot light.

Warning
 Although electrodes are at the farthest, do not insert your finger(s) inside while removing pilot light. It may result in an electric shock .

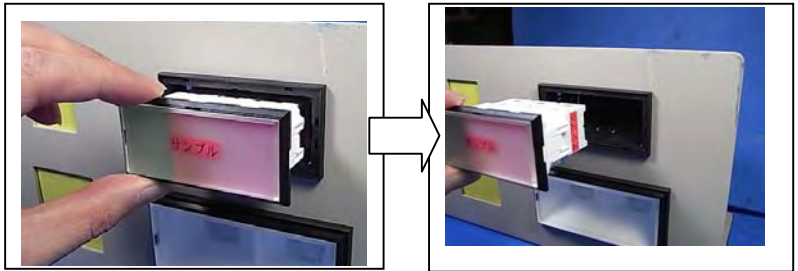

Step 3. Checking for models

3.1 Rectangular parts are located on the back of the removed pilot light.



X: Yellow one is concerned and needs to be replaced.
 O: Black one is not concerned and doesn't need to be replaced.
 *The picture on the right shows both yellow and black ones as an example.

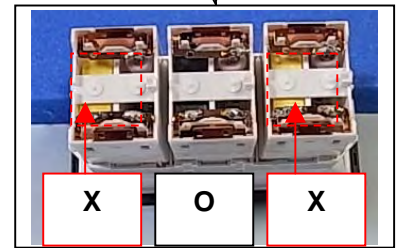

3.2 Checking LED unit specification
 Check its rated voltage, LED specification, and LED color.
 Replace with the same spec product.

1. Rated voltage and LED color

[220G] => 200Vac-220Vac

[220G] => G means LED's color is green

2.LED specification and LED color

[2MG] => Type of unit 2M or 3M

*Use 3M for 3-partition red (R) / orange (A) / white (W).

[2MG] => G means LED's color is green

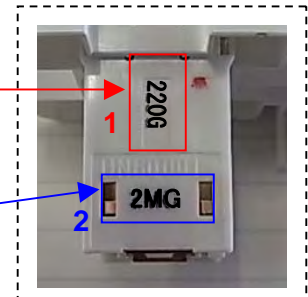

Step 4. Removing LED unit

4.1 Pilot light consists of "LED unit" and "Reflector"

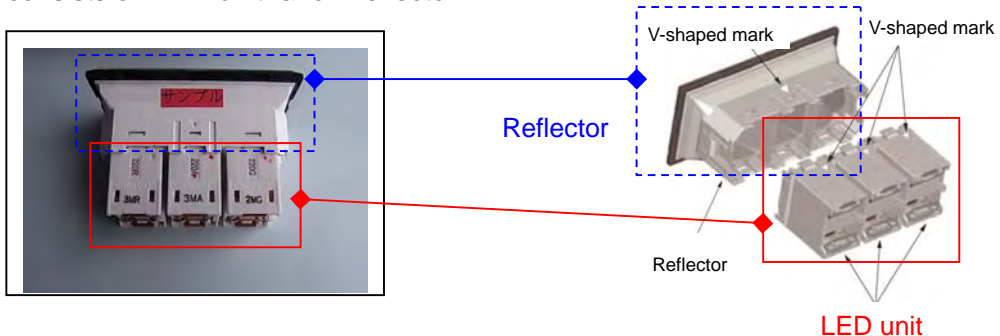

4.2 Insert a flat-blade screwdriver into a gap of a snap fit

1. Insert the screwdriver 2-3mm deep => 2. Slant it a little in the direction of the arrow => 3. Pull the LED unit

Note Do not hitch the screwdriver. It may damage the product.

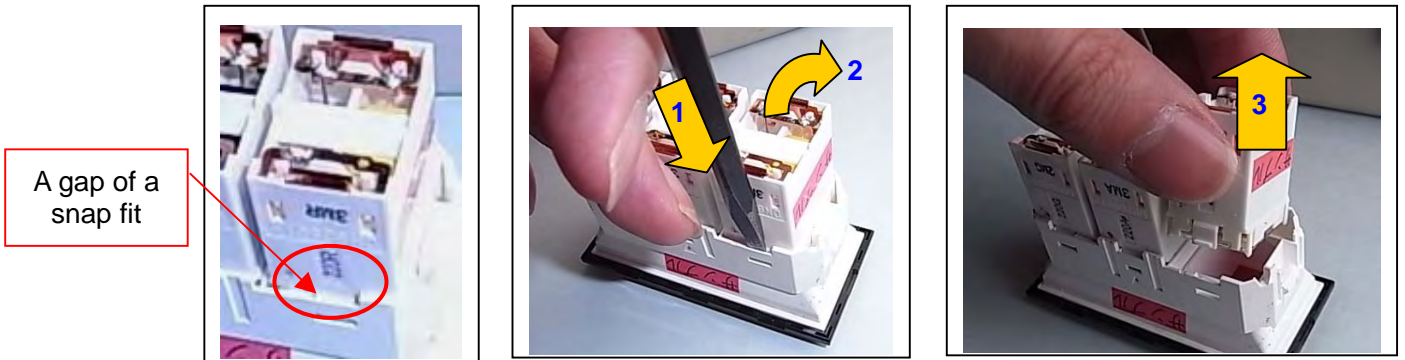

Step 5. Re-mounting LED unit

5.1 Check the specification of LED unit to be attached. Attach the same spec unit.

(Please see Step 3. 3.2 for checking LED unit)

5.2 “LED unit” and “Reflector” have attaching direction.

V-shaped marks of the LED unit and reflector should be seen on the same side.

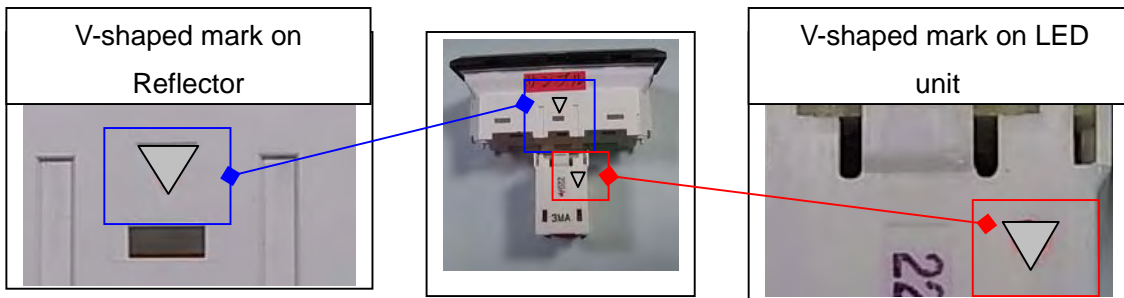

5.3 Attach a LED unit straight into a reflector one by one.

Attaching at a slant may damage the snap fit.

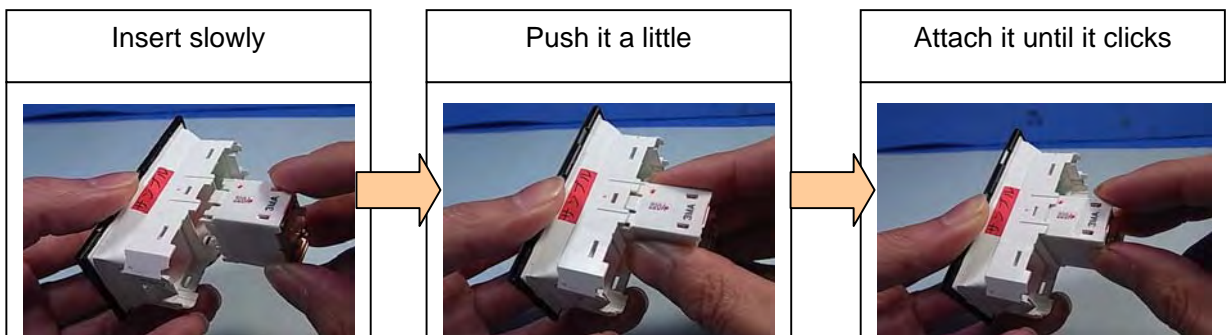

Step 6. Re-installing Pilot Light

Install the pilot light into the frame (panel board).

6.1 Reflector has installing direction. Check it before installing.

V-shaped mark should be on the upper side.

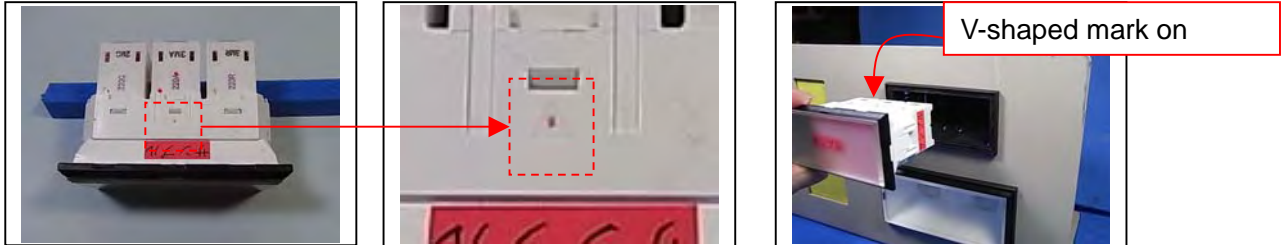

6.2 Install the pilot light into the frame.

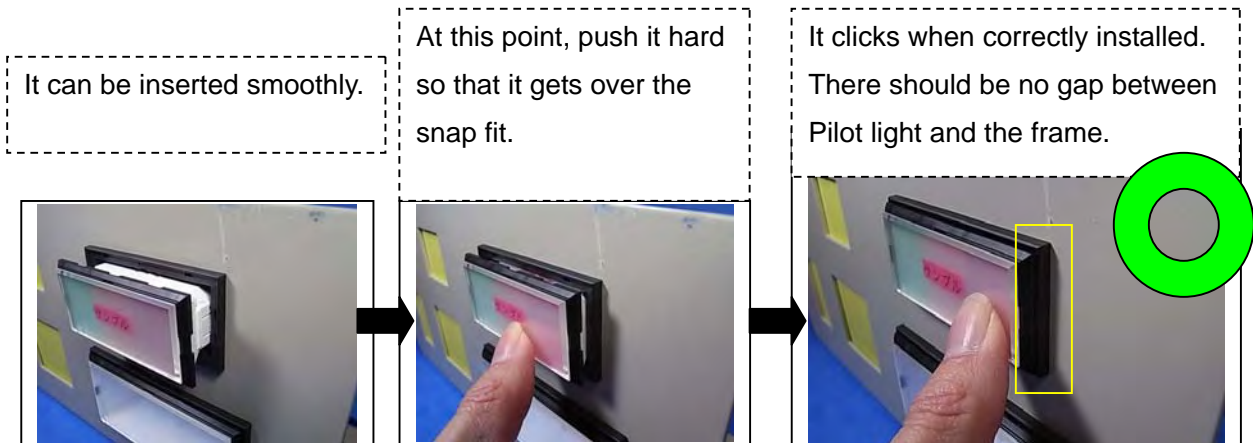

Note It cannot be installed if it is upside down.
Try again with the right direction.

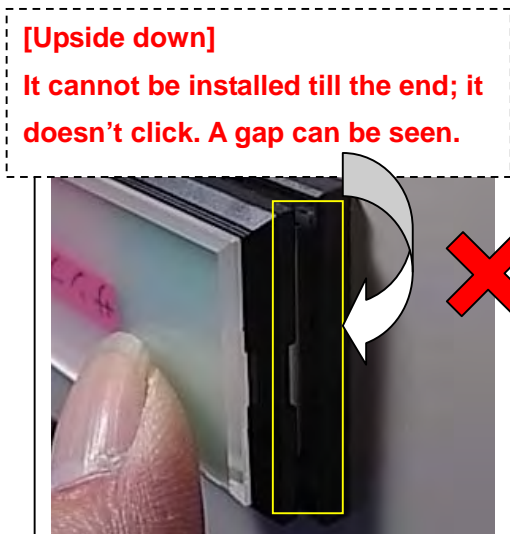

Replacement is completed.

April 21st 2010