

# Magnetic Contactors and Starters

## SC and SW series

### Versions

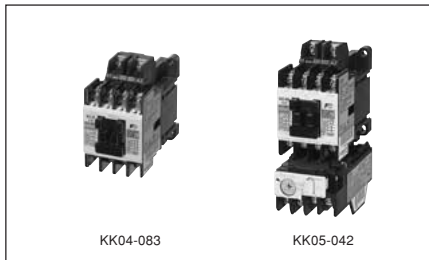

**Standard type contactors and starters**

Standard type is usually used to start and stop motors, and to open and close resistance loads like heaters or electric furnaces.  
See page 01/33.



**Contactors and starters with SUPER MAGNET**

IC operated SUPER MAGNET prevents coil burning and contact welding due to voltage fluctuations  
See page 01/33.



**Enclosed type starters**

Standard type starter are housed in a protective enclosure.  
See page 01/41.



**Reversing contactors and starters**

This type is most suitable for reversing operation of 3-phase motors or plugging or braking.  
See page 01/42.

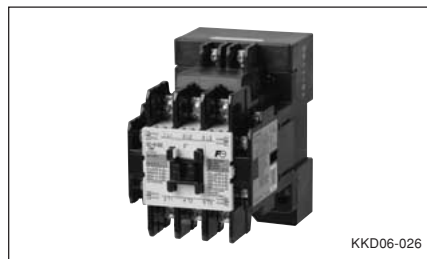

**DC-operated contactors and starters**

Main circuit is AC, and operation is carried out by DC operating coil. This type is useful for applications in which control power source is independent.  
See page 01/49.

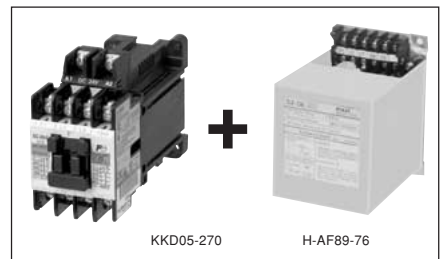

**OFF-delay release contactors and starters**

This is a combination of DC-operated magnetic contactor and off-delay release unit. This prevents circuit opening due to instantaneous voltage drops.  
See page 01/54.



**With extra pickup operating coil**

These contactors are suitable for use in places with poor power supply conditions. These contactors operate normally even if the coil input voltage falls to 75% of the coil rated voltage.  
See page 01/55.

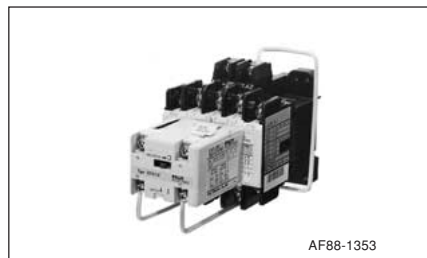

**Mechanical latch contactors**

Latch mechanism prevents the circuit from opening due to power failure, instantaneous power failure, or voltage drop of power source. This is suitable for change-over circuit and stand-by power supply equipment.  
See page 01/56.

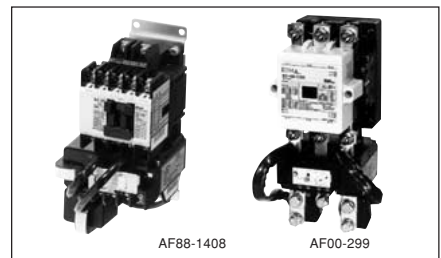

**Heavy starting duty starters**

This is suitable for overload protection or stall prevention of motors with longer starting times such as those for blowers and fans having a large inertia.  
See page 01/61.

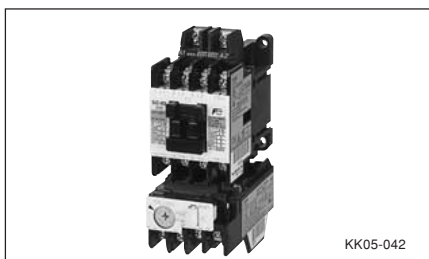

KK05-042

**Starters with quick-operating overload relay**

With the attached quick operating type O/L relay, this is suitable for protecting submersible pumps or compressor motors with a small heat capacity.  
 See page 01/63.

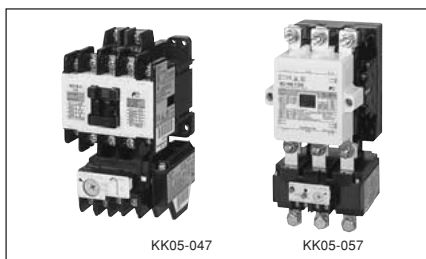

KK05-047

KK05-057

**Starters with phase-loss protective device**

The attached 2E thermal O/L relay protects against motor overload and as well as phase-loss.  
 See page 01/64.

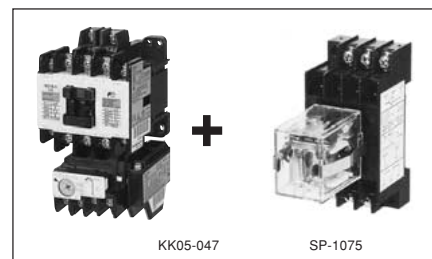

KK05-047

SP-1075

**Starters with phase-loss and phase-sequence protective device**

By combining 2E thermal O/L relay and phase-sequence relay, motor overload, phase-loss and phase-sequence protection is obtained.  
 See page 01/66.

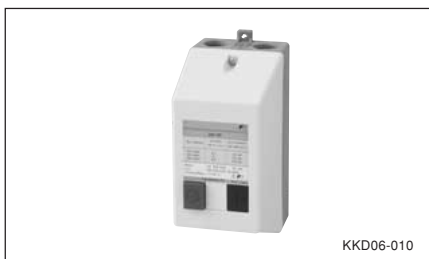

KKD06-010

**Starters with on-off and RESET pushbuttons**

Pushbuttons for close and open are built in the enclosure. Suitable for simple operations.  
 See page 01/68.



SD-704

**Dust-tight/light-corrosion resistant type starters**

The enclosure is dust-tight and corrosion-proof, and so is suitable for locations with dusty or corrosive atmospheres.  
 See page 01/70.

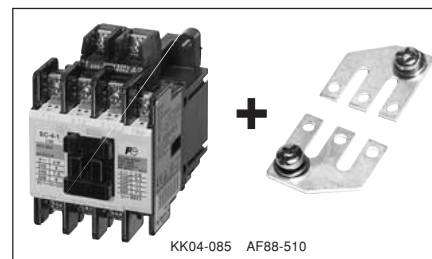

KK04-085

AF88-510

**Contactors for single-phase resistance load**

This is a standard type magnetic contactor with a 3-phase parallel plate terminal. This is most suitable for on-off operation of electric heaters, water heaters and electric lights.  
 See page 01/71.

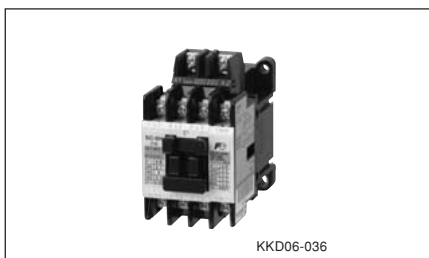

KKD06-036

**With single-button auxiliary contacts**

An auxiliary contact of a standard contactor is bifurcated. All SC-03H to SC-N12H contactor, however, feature single-button auxiliary contacts with a higher current rating than the contacts used by the standard contactor.  
 See page 01/72.



AF95-240

**With quick connection terminals**

No removing terminal screw is required. When contactor and starters with the quick connection terminals are shipped, these screws are inserted in the terminals section but make no contact. It reduces the number of wiring steps. Terminals with finger protection enable a high level of safety.  
 See page 01/73.

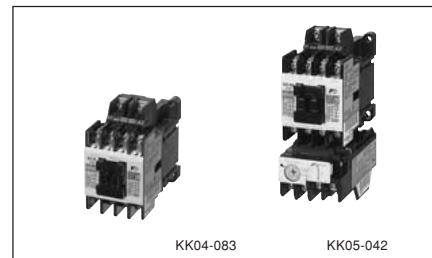

KK04-083

KK05-042

**UL, CSA, TÜV and CCC approved motor starters and contactors**

Many models of SC series conform to UL, CSA, TÜV and CCC requirements.  
 See page 01/129.

**DC operated contactors and starters**

Up to 37kW 440 Volts

■ **Description**

In most cases general purpose AC magnetic motor starters employ AC coils, and although “AC motor with AC controls” is the normal practice, in complicated controls troubles can be expected due to the instantaneous voltage drop or power failure in the AC power source. Thus, in some applications “AC motor with DC control” offers a better system.

FUJI manufactures two types of DC operated contactors. In one type the ON/OFF operation is carried out by a DC operating coil. The other type is operated by the SUPER MAGNET. The SC-03/G to N3/G types use the single coil system. They can be operated at full voltage. When requiring the DC operation for SC-N1 to N4 contactor, the contactor with SUPER MAGNET is substituted(SC-N1/SE to N4/SE). AC/DC operated types with SUPER

MAGNET  
 • SC-N1/SE to N4/SE, SW-N1/SE to N4/SE

• SC-N5 to N16, SW-N5/3H to 14/3H  
 These standard types employ the SUPER MAGNET.

■ **Ordering information**

Specify the following:

1. Ordering code
2. Operating coil voltage code
3. Contact arrangement:

In the case of the frame size 0/G to 5-1/G, specify the contact arrangement.

4. Overload relay setting range code.

■ **Ratings**

Max. motor capacity (kW)		Operational current (A)		Thermal current (A)	Auxiliary contact		Contactor Type	Starter (3-element) Type
200V	380V	200V	380V		NO	NC		
240V	440V	240V	440V					
2.5	4	11	9	20	1	—*1	SC-03/G	SW-03/G3H
3.5	5.5	13	12	20	1	—*1	SC-0/G	SW-0/G3H
3.5	5.5	13	12	20	1	1*2	SC-05/G	SW-05/G3H
4.5	7.5	18	16	25	1	—*1	SC-4-0/G	SW-4-0/G3H
5.5	11	22	22	32	1	—*1	SC-4-1/G	SW-4-1/G3H
5.5	11	22	22	32	1	1*3	SC-5-1/G	SW-5-1/G3H
7.5	15	32	32	50	2	2	SC-N1/G	SW-N1/G3H
11	18.5	40	40	60	2	2	SC-N2/G	SW-N2/G3H
15	22	50	50	80	2	2	SC-N2S/G	SW-N2S/G3H
18.5	30	65	65	100	2	2	SC-N3/G	SW-N3/G3H
7.5	15	32	32	50	2	2	SC-N1/SE	SW-N1/SE3H
11	18.5	40	40	60	2	2	SC-N2/SE	SW-N2/SE3H
15	22	50	50	80	2	2	SC-N2S/SE	SW-N2S/SE3H
18.5	30	65	65	100	2	2	SC-N3/SE	SW-N3/SE3H
22	40	80	80	135	2	2	SC-N4/SE	SW-N4/SE3H

Notes: 1. \*1 Auxiliary contact 1NC is available. \*2 Auxiliary contact 2NO or 2NC is available.  
 \*3 Auxiliary contact 2NO, 2NC, or 2NO+2NC is available. For enclosed type, 2NO+2NC is not available  
 2. Auxiliary contact 4NO+4NC is available on request for frame size N1 and above.



■ **Coil ratings**

Type	Coil voltage (V DC)	Power consumption (W)		Operating characteristic (V)	
		Inrush (W)	Sealed (W)	Pick-up voltage (V)	Drop-out voltage (V)
SC-03/G	12, 24, 48, 60,	7	7	88–124	24–52
SC-0/G	100, 110, 120	7	7	88–124	24–52
SC-05/G	200, 210, 220	7	7	86–122	28–56
SC-4-0/G		7	7	92–128	28–56
SC-4-1/G		7	7	92–128	28–56
SC-5-1/G		7	7	92–130	30–60
SC-N1/G		9	9	80–120	30–70
SC-N2/G		9	9	80–120	30–70
SC-N2S/G		12	12	80–120	24–60
SC-N3/G		12	12	80–120	24–60
SC-N1/SE	100–120 *1	150	2.6	140–160	40–100
SC-N2/SE	200–240 *2	150	2.6	140–160	40–100
SC-N2S/SE		185	2.7	140–160	40–100
SC-N3/SE		185	2.7	140–160	40–100
SC-N4/SE	24, 48	110	3.0	140–160	40–100

Notes: Operating coil voltage 200V DC for 03/G to N3/G  
 220V DC for N1/SE to N4/SE

\*1 The coil voltage from a DC power supply with single phase full-wave rectification will be 100 to 110 V.

\*2 The coil voltage from a DC power supply with single phase full-wave rectification will be 200 to 220 V.

■ **UL, CSA, TÜV and CCC approved:**  
 See page 01/129, 136, 140.

■ **Auxiliary contact**  
 Same as standard type, See page 01/28.

# Magnetic Contactors and Starters

## SC and SW series

### DC operated

#### ■ Dimensions

#### DC operated contactors

#### SC-03/G, SC-0/G

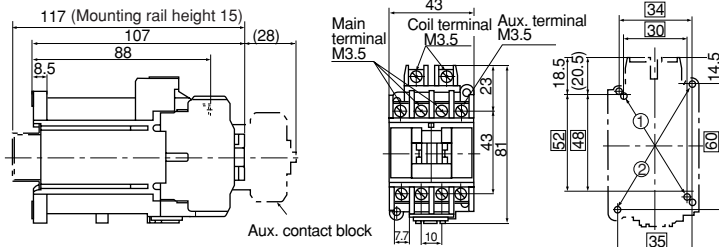

Mass:0.55kg

#### ■ Wiring diagrams

Auxiliary contact

1NO

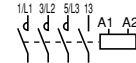

1NC

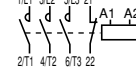

#### SC-05/G

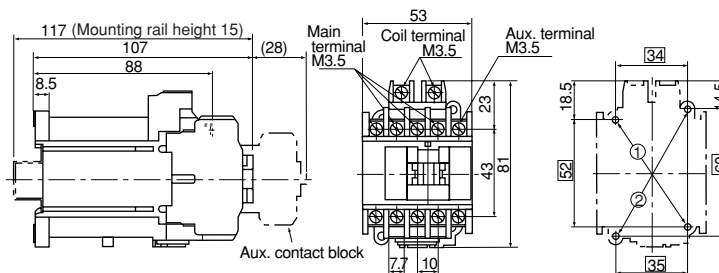

Mass:0.58kg

2NO

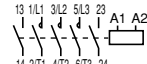

1NO+1NC

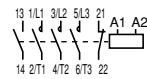

2NC



#### SC-4-0/G, SC-4-1/G

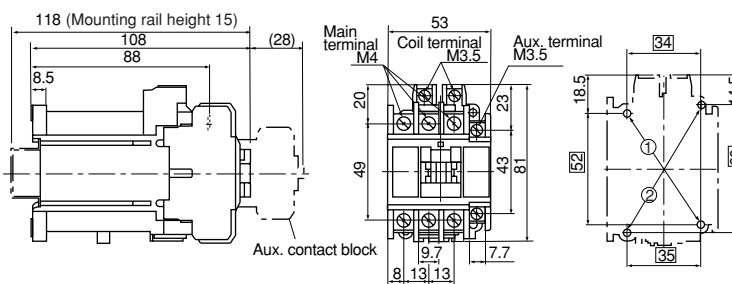

Mass:0.6kg

1NO

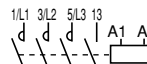

1NC

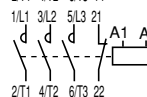

#### SC-5-1/G

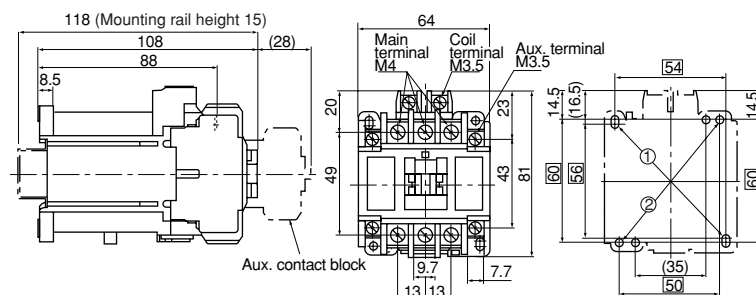

Mass:0.62kg

2NO

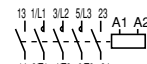

1NO+1NC

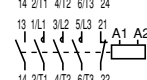

2NC

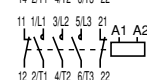

Note: Use the two mounting holes on a diagonal line to mount a contactor.  
Mounting holes indicated by ① are compatible with those of SRC type.  
Mounting holes indicated by ② are compatible with IEC standard

■ Dimensions  
 DC operated contactors  
**SC-N1/G, SC-N2/G**

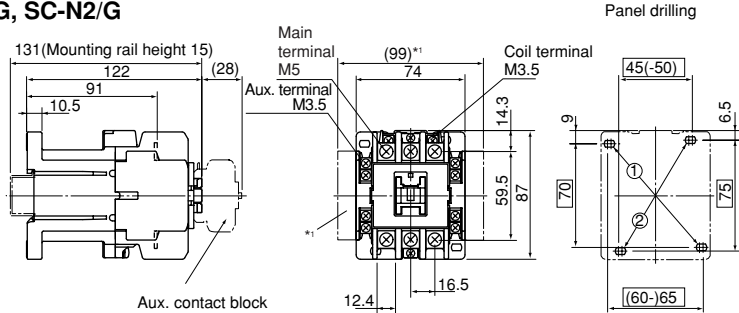

Mass: 0.82kg

\*1 For two side mounting aux. contact blocks mounted

**SC-N2S/G, SC-N3/G**

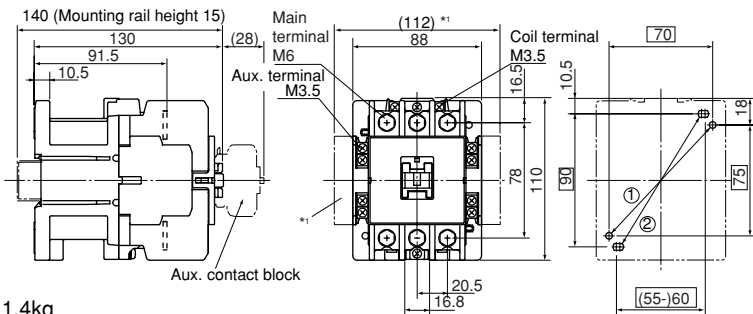

Mass: 1.4kg

\*1 For two side mounting aux. contact blocks mounted

■ Wiring diagrams  
**SC-N1/G to SC-N3/G**

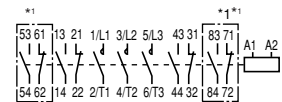

\*1 In case of auxiliary contact 4NO+4NC

DC operated starters  
**SW-03/G3H, SW-0/G3H**

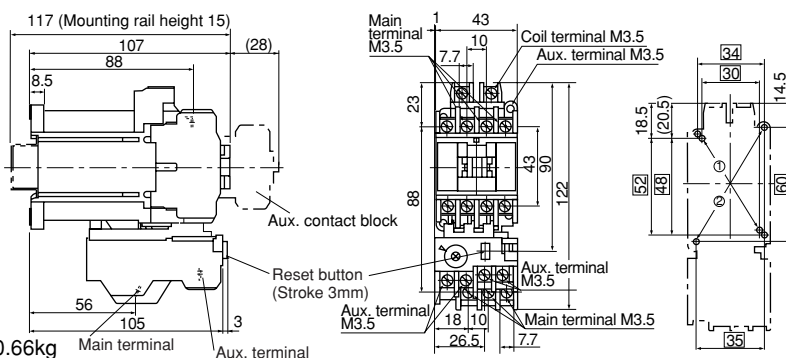

Mass: 0.66kg

**SW-05/G3H**

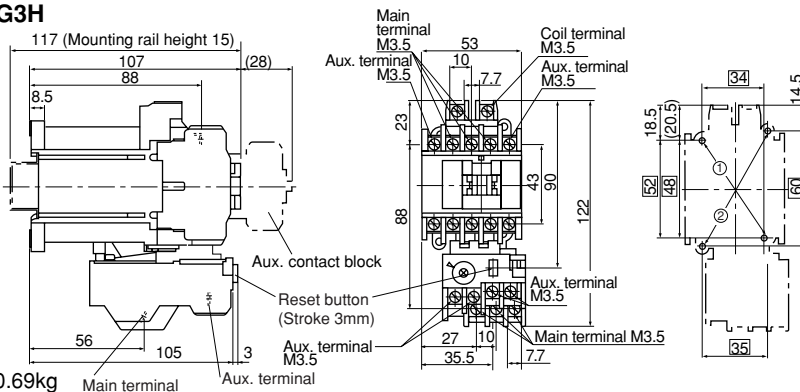

Mass: 0.69kg

■ Wiring diagrams

Auxiliary contact

1NO

1NC

2NO

1NO+1NC

2NC

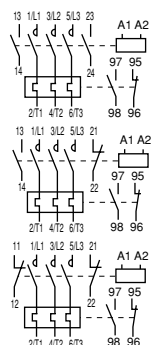
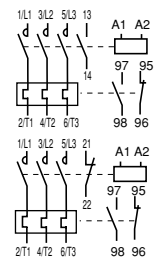

Note: Use the two mounting holes on a diagonal line to mount a contactor.  
 Mounting holes indicated by ① are compatible with those of SRC type.  
 Mounting holes indicated by ② are compatible with IEC standard

# Magnetic Contactors and Starters

## SC and SW series

### DC operated

#### ■ Dimensions

#### DC operated starters

#### SW-4-0/G3H, SW-4-1/G3H

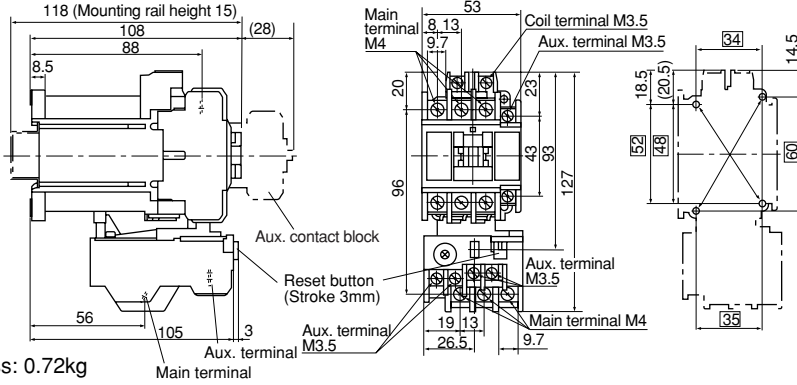

#### SW-5-1/G3H

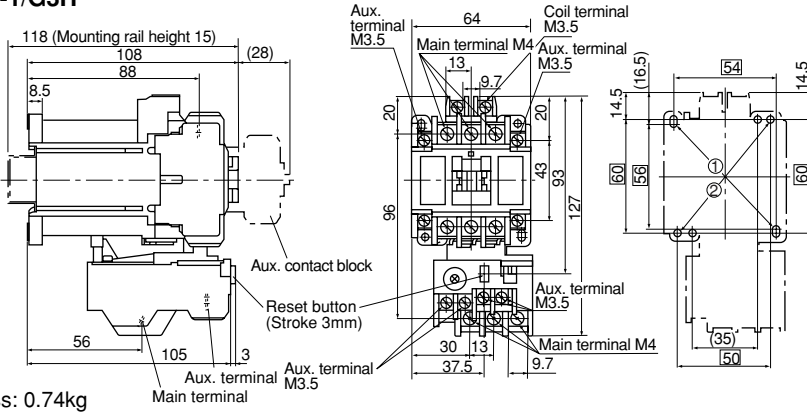

#### SW-N1/G3H, SW-N2/G3H

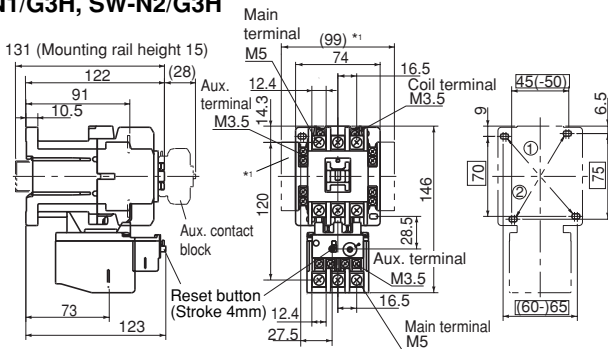

#### SW-N2S/G3H, SW-N3/G3H

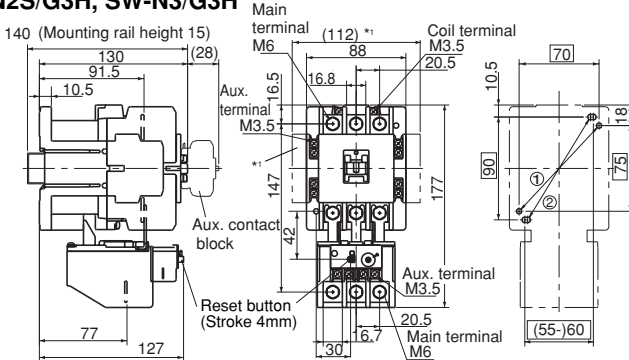

#### ■ Wiring diagrams

Auxiliary contact

1NO



1NC

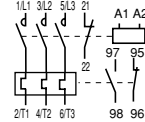

2NO

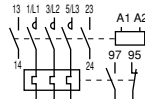

1NO+1NC

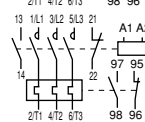

2NC

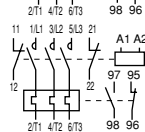

#### ■ Wiring diagrams

#### SW-N1/G3H to SW-N3/G3H

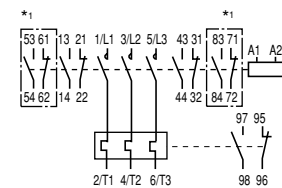

\*1 In case of auxiliary contact 4NO+4NC

Note: • Use the two mounting holes on a diagonal line to mount a contactor.  
 Mounting holes indicated by ① are compatible with those of SRC type.  
 Mounting holes indicated by ② are compatible with IEC standard  
 \*1 For two side mounting aux. contact blocks mounted  
 \*2 For front mounting aux. contact blocks mounted

■ Dimensions  
 DC operated contactors

SC-N1/SE, SC-N2/SE

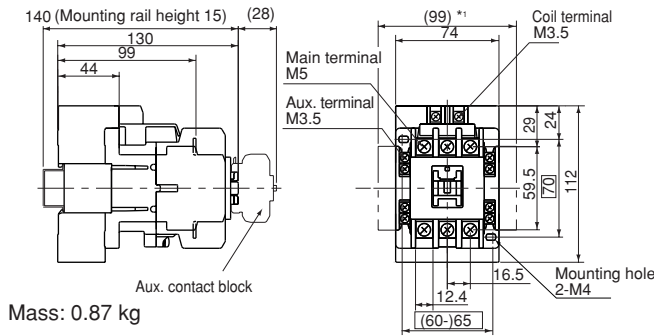

SC-N4/SE

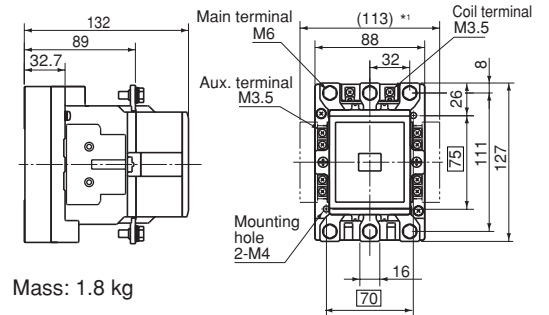

SC-N2S/SE, SC-N3/SE

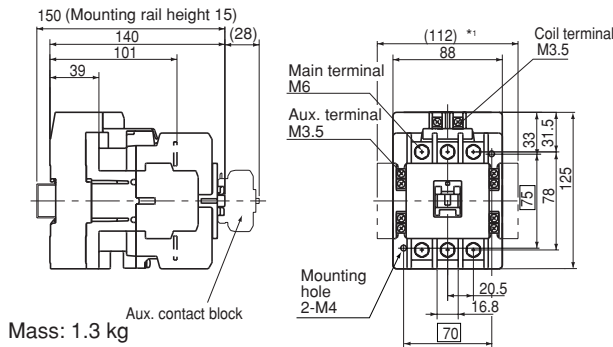

■ Wiring diagrams  
 SC-N1/SE to SC-N4/SE

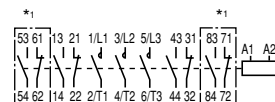

\*1 In case of auxiliary contact 4NO+4NC

Dimension for SC-N5 to SC-N16 types  
 Same as standard open type  
 See page 01/35, 01/36

DC operated starters  
 SW-N1/SE3H, SW-N2/SE3H

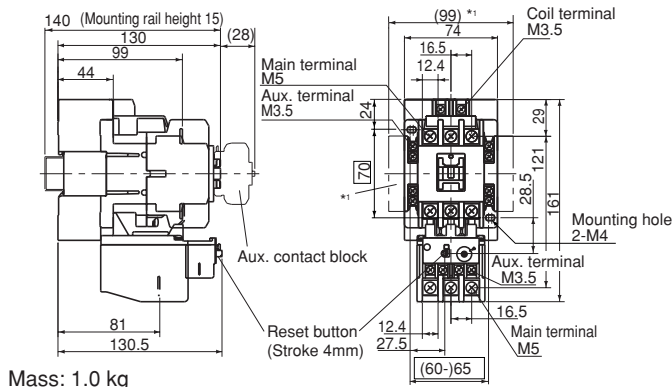

SW-N4/SE3H

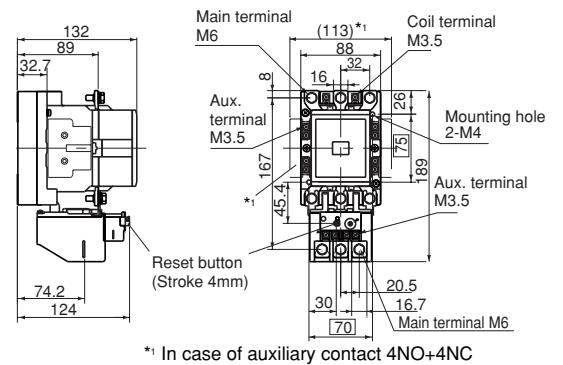

\*1 In case of auxiliary contact 4NO+4NC

SW-N2S/SE3H, SW-N3/SE3H

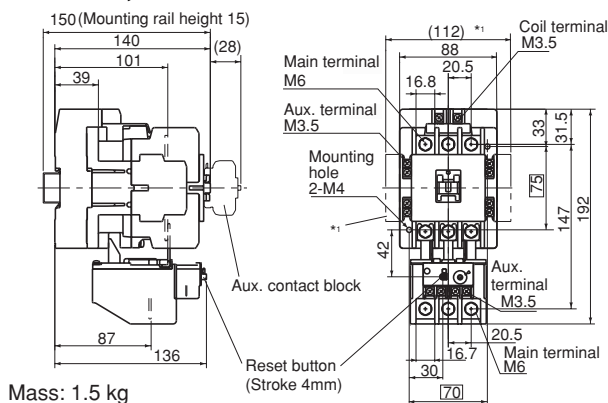

■ Wiring diagrams  
 SW-N1/SE3H to SW-N4/SE3H

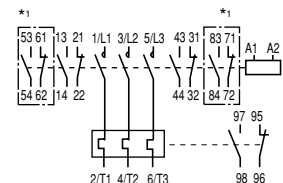

\*1 In case of auxiliary contact 4NO+4NC

Dimension for SW-N5/3H to SW-N14/3H types  
 Same as standard open type  
 See page 01/39, 01/40

Note: \*1 For two side mounting aux. contact blocks mounted

# Magnetic Contactors and Starters

## SC and SW series

### OFF-delay release

#### OFF-delay release type

##### ■ Description

This type contactor consists of DC-operated contactor and off-delay release unit, and the contacts are released with a delay of 1-4 or 1-5 seconds after the coil has been de-energized. When the standard type contactor suffers an instantaneous voltage drop

in the AC power supply or a power failure takes place the operating coils are de-energized and the reclosing of the contacts must be carried out every time. The off-delay release contactor is so designed that in the event of a brief power outage the coil will not release the contacts and the power is maintained making reclosing action unnecessary.

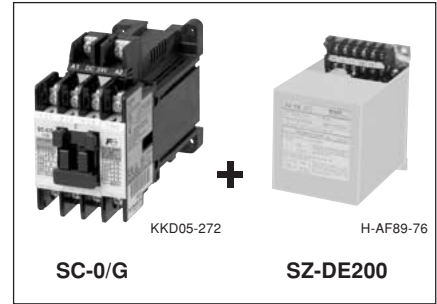

#### ■ Combination of OFF-delay release units and contactors

Contactor Type	Ordering code	Starter (3-element)		OFF-delay release unit	
		Type	Ordering code	Type	Ordering code
SC-03/G	SC11AG-■10	SW-03/G3H	SC11AGN-■10T□D	<b>SZ-DE</b> □	SZ1DE□
SC-0/G	SC13AG-■10	SW-0/G3H	SC13AGN-■10T□D		
SC-05/G	SC14AG-■11	SW-05/G3H	SC14AGN-■11T□D		
SC-4-0/G	SC18AG-■10	SW-4-0/G3H	SC18AGN-■10T□D		
SC-4-1/G	SC19AG-■10	SW-4-1/G3H	SC19AGN-■10T□D		
SC-5-1/G	SC20AG-■11	SW-5-1/G3H	SC20AGN-■11T□D		
SC-N1/G	SC25BAG-■22	SW-N1/G3H	SC25BAGN-■22T□D	<b>SZ-N1/GDE</b> □	SZ2N1GDE-□
SC-N2/G	SC35BAG-■22	SW-N2/G3H	SC35BAGN-■22T□D		
SC-N2S/G	SC50BAG-■22	SW-N2S/G3H	SC50BAGN-■22T□D		
SC-N3/G	SC65BAG-■22	SW-N3/G3H	SC65BAGN-■22T□D		
SC-N4/SE	SC80BAS-■22	SW-N4/SE3H	SC80BASN-■22T□D		
SC-N5	SC93BAA-■22	SW-N5/3H	SC93BAAN-■22T□D		
SC-N6	SC1CBAA-■22	SW-N6/3H	SC1CBAAN-■22T□D		
SC-N7	SC1FBAA-■22	SW-N7/3H	SC1FBAAN-■22T□D		
SC-N8	SC1JBAA-■22	SW-N8/3H	SC1JBAAN-■22T□D		
SC-N10	SC2CBAA-■22	SW-N10/3H	SC2CBAAN-■22T□D		
SC-N11	SC3ABAA-■22	SW-N11/3H	SC3ABAAN-■22T□D		
SC-N12	SC4ABAA-■22	SW-N12/3H	SC4ABAAN-■22T□D		
SC-N14	SC6ABAA-■22	SW-N14/3H	SC6ABAAN-■22T□D		

- Notes: 1. For contactor and starter.  
 Enter the coil voltage code in the ■ mark.  
 Enter the thermal overload relay ampere setting range code in the □ mark.  
 2. For off-delay release unit.  
 Enter the control voltage code in the □ mark.

#### ● OFF-delay release unit ordering code

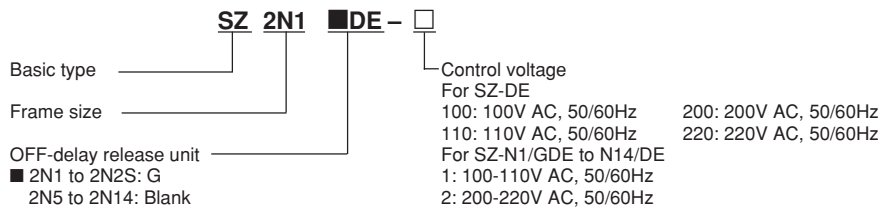

Note: If OFF-delay release contactors (starters) having capacities of frame size 03 to N3 are required the DC operated contactors (starters) will be combined with the OFF-delay release unit. When ordering make sure that the input voltage (AC) of the OFF-delay release unit is equal to the operating voltage (DC) of the contactors (starters).

Example:  
 SZ-N5/DE 100V AC 50Hz+SC-N5 100V DC  
 (OFF-delay release unit) + (Contactor)

#### ■ Performance data

Frame	Hold time	Making/breaking capacity	Operating cycles per hour	Life expectancy (operations)	
				Electrical	Mechanical
03/G to 5-1/G	1-5 sec.	10×le / 8×le	600	2 million*1	10 million
N1/G, N2/G	1-5 sec.	10×le / 8×le	600	2 million	10 million
N2S/G, N3/G	1-5 sec.	10×le / 8×le	600	2 million	5 million
N4/SE	1-4 sec.	10×le / 8×le	600	1 million	5 million
N5 to N11	1-4 sec.	10×le / 8×le	600	1 million	5 million
N12	1-4 sec.	10×le / 8×le	600	500,000	5 million
N14	1-4 sec.	10×le / 8×le	600	500,000	5 million

le: Rated operational current  
 Capacitor life: 100,000 operations  
 \*1 Frame size 4-0: 1.5 million  
 Conforming to Class AC-3, IEC 60947-4-1

#### OFF-delay release unit

##### ■ Wiring diagrams

##### SZ-DE100, 110, 200, 220

##### SZ-N1/GDE, N2S/GDE

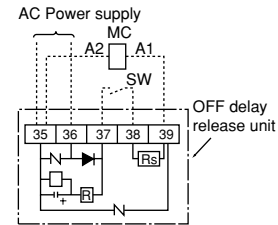

##### SZ-N5/DE to N14/DE

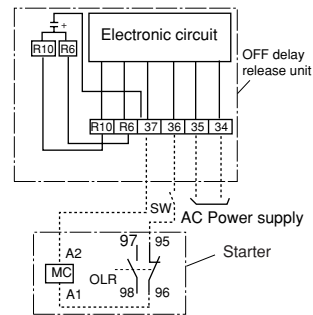

#### ■ Dimensions, mm

##### SZ-DE100, 110, 200, 220

##### SZ-N1/GDE, N2S/GDE

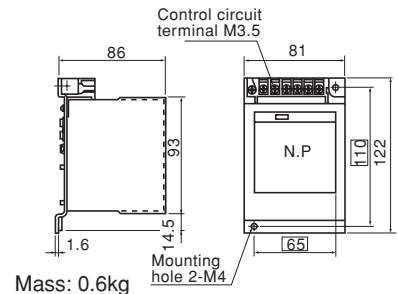

##### SZ-N5/DE to N14/DE

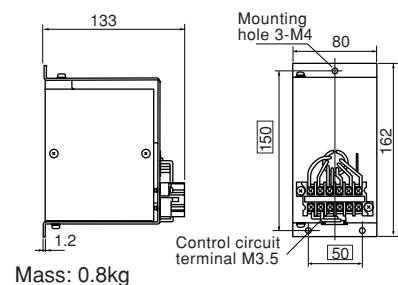

**Contactors and starters with extra pick-up operating coil**

■ **Description**

Generally, if the operating coil voltage of the contactor is within 85%–110% of its rated value normal operation can be expected. However, should the power source have a low capacity or if the supply point is some distance away from the power source a voltage drop can be expected and voltage may fall below 85% of its rated value under motor starting or similar conditions. Direct-on-line starting under these circumstances may result in poor starter performance, contacts welding together and coils overheating. The FUJI U-type contactors are provided with an extra operating coil which performs correctly even if the voltage is only 75% of its rated value. This starter is recommended for use in locations

where reduced voltage conditions are met. Standard types for frame sizes N5 and above can be used as the contactor or starter with extra pick-up operating coil. Enclosed type starters (03 to N4) are also available.

- **Ratings:** See page 01/28.
- **Coil voltage:** See page 01/30.
- **Dimensions:** Same as standard type. See page 01/34, 01/35.
- **Thermal overload relay:** See page 01/97.

■ **Ordering information**

- Specify the following:
1. Ordering code
  2. Motor ratings: Voltage, frequency, capacity (kW) and full load current.
  3. Operating coil voltage code

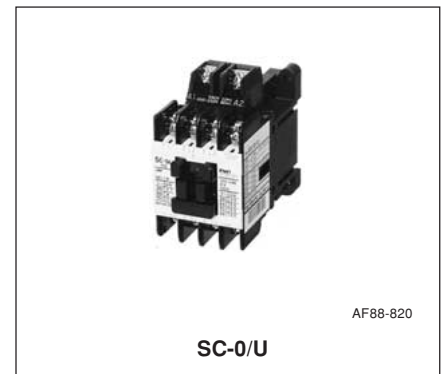

■ **Coil characteristics**

Contactor Type	Ordering code	Starter (3-element)		Aux. contact		Power consumption		Pick-up voltage (V)		Drop-out voltage (V)	
		Type	Ordering code	NO	NC	Inrush (VA)	Sealed (VA)	200V 50Hz	220V 60Hz	200V 50Hz	220V 60Hz
SC-03/U	SC11AU-■10	SW-03/U3H	SC11AUN-■10T□D	1	— *1	120	15	93–115	102–124	58–88	66–96
SC-0/U	SC13AU-■10	SW-0/U3H	SC13AUN-■10T□D	1	— *1	120	15	93–115	102–124	58–88	66–96
SC-05/U	SC14AU-■11	SW-05/U3H	SC14AUN-■11T□D	1	1 *2	120	15	93–116	103–126	60–90	70–99
SC-4-0/U	SC18AU-■10	SW-4-0/U3H	SC18AUN-■10T□D	1	— *1	120	15	100–120	110–130	63–90	73–100
SC-4-1/U	SC19AU-■10	SW-4-1/U3H	SC19AUN-■10T□D	1	— *1	120	15	100–120	110–130	63–90	73–100
SC-5-1/U	SC20AU-■11	SW-5-1/U3H	SC20AUN-■11T□D	1	1 *2	120	15	99–121	110–130	64–96	74–102
SC-5-1/U	SC20AU-■22	SW-5-1/U3H	SC20AUN-■22T□D	2	2	120	15	99–121	110–130	64–96	74–102
SC-N1/U	SC25BAU-■22	SW-N1/U3H	SC25BAUN-■22T□D	2	2 *3	130	13	104–122	114–132	68–88	80–98
SC-N2/U	SC35BAU-■22	SW-N2/U3H	SC35BAUN-■22T□D	2	2 *3	130	13	104–122	114–132	68–88	80–98
SC-N2S/U	SC50BAU-■22	SW-N2S/U3H	SC50BAUN-■22T□D	2	2 *3	195	14.3	104–120	118–134	72–90	84–102
SC-N3/U	SC65BAU-■22	SW-N3/U3H	SC65BAUN-■22T□D	2	2 *3	195	14.3	104–120	118–134	72–90	84–102
SC-N4/U	SC80BAU-■22	SW-N4/U3H	SC80BAUN-■22T□D	2	2 *3	235	20	104–120	118–134	72–90	84–102

Notes: 1 The standard SC-N5 to SC-N16 types are provided with the SUPER MAGNET which holds without chattering even if the line voltage drops to 65% of its rated value, so preventing the troubles such as contact welding or coil burning.  
 2. \*1 Auxiliary contact 1NC is available on request.  
 \*2 Auxiliary contact 2NO or 2NC is available on request.  
 \*3 Auxiliary contact 4NO+4NC is available on request  
 3. Enter the coil voltage code in the ■ mark.  
 Enter the thermal overload relay ampere setting range code in the □ mark.

■ **Performance data**

Type	Make and break capacity	Operating cycles per hour	Life expectancy (operations)	
			Electrical	Mechanical
Contactor	Starter			
SC-03/U	SW-03/U3H	IEC60947-4-1 class AC-3	2 million	2.5 million
SC-0/U	SW-0/U3H	Make: 10×Ie	2 million	2.5 million
SC-05/U	SW-05/U3H	Break: 8×Ie	2 million	2.5 million
SC-4-0/U	SW-4-0/U3H	(Ie : Operational current)	2 million	2.5 million
SC-4-1/U	SW-4-1/U3H		2 million	2.5 million
SC-5-1/U	SW-5-1/U3H		2 million	2.5 million
SC-N1/U	SW-N1/U3H		2 million	2.5 million
SC-N2/U	SW-N2/U3H		1 million	1 million
SC-N2S/U	SW-N2S/U3H		1 million	1 million
SC-N3/U	SW-N3/U3H		1 million	1 million
SC-N4/U	SW-N4/U3H		1 million	1 million

# Magnetic Contactors

## SC series

### Mechanical latch

#### Mechanical latch contactors

Up to 315kW 440 Volts AC 3-phase

#### ■ Description

Mechanical latch contactors are used where operating sequence continuity must be maintained regardless of any outside interruptions, such as voltage failure or instantaneous voltage drop. Typical applications are for electric furnaces, machine tool circuits, standby power supply and normal power changeover circuits in hospitals, schools and office buildings. These contactors are provided with two coils. One is CC (Closing Coil) and the other is TC (Tripping Coil). An interlocking circuit is provided between the CC coil and the TC coil. Since a coil voltage is not applied during operation it is extremely quiet. Power consumption can also be saved.

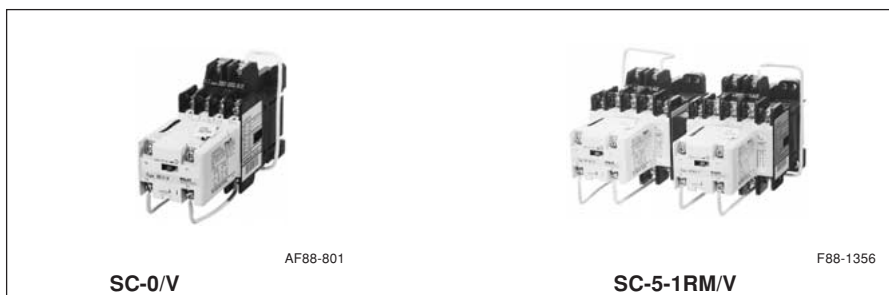

#### ■ Performance data

Frame size	Making capacity	Breaking capacity	Operating cycles per hour	Life expectancy (operations)	
				Electrical	Mechanical
<b>03/V to 5-1/V, 03/VG to 5-1/VG N1/VS to N3/VS N4/VS to N12/VS N14/VS</b>	10×Ie	8×Ie	1200	500,000	1 million
	10×Ie	8×Ie	600	500,000	500,000
	10×Ie	8×Ie	600	250,000	250,000
	10×Ie	8×Ie	600	100,000	100,000

Notes: Ie: Rated operational current.

- Mechanical latch units cannot be sold separately. Such units are only sold attached to contactors.
- Do not detach mechanical latch units from contactors and do not make modifications such as attaching mechanical latch units to other contactors.

#### ■ Types and ratings

##### • AC, AC/DC operated

Max. motor capacity (kW)						Rated operational current (A)			Rated thermal current Ith (A)	Non-reversing			Reversing				
200V	380V	200V	380V	240V	440V	200V	380V	240V		440V	Type	Aux. contact NO	NC	Ordering code	Type	Aux. contact NO	NC
2.5	4	11	9	20						<b>SC-03/V</b>	–	–	SC11AV-■00	<b>SC03RM/V</b>	–	–	SC11RV-■00
3.5	5.5	13	12	20						<b>SC-0/V</b>	–	–	SC13AV-■00	<b>SC0RM/V</b>	–	–	SC13RV-■00
3.5	5.5	13	12	20						<b>SC-05/V</b>	1	–	SC14AV-■10	<b>SC05RM/V</b>	2	–	SC14RV-■10
3.5	5.5	13	12	20							–	1	SC14AV-■01		–	2	SC14RV-■01
4.5	7.5	18	16	25						<b>SC-4-0/V</b>	–	–	SC18AV-■00	<b>SC-4-0RM/V</b>	–	–	SC18RV-■00
5.5	11	22	22	32						<b>SC-4-1/V</b>	–	–	SC19AV-■00	<b>SC-4-1RM/V</b>	–	–	SC19RV-■00
5.5	11	22	22	32						<b>SC-5-1/V</b>	1	–	SC20AV-■10	<b>SC-5-1RM/V</b>	2	–	SC20RV-■10
5.5	11	22	22	32							–	1	SC20AV-■01		–	2	SC20RV-■01
5.5	11	22	22	32							1	2	SC20AV-■12		2	4	SC20RV-■12
7.5	15	32	32	50						<b>SC-N1/VS</b>	2	2	SC25BAE-■22	<b>SC-N1RM/VS</b>	4	4	SC25BRE-■22
11	18.5	40	40	60						<b>SC-N2/VS</b>	2	2	SC35BAE-■22	<b>SC-N2RM/VS</b>	4	4	SC35BRE-■22
15	22	50	50	80						<b>SC-N2S/VS</b>	2	2	SC50BAE-■22	<b>SC-N2SRM/VS</b>	4	4	SC50BRE-■22
18.5	30	65	65	100						<b>SC-N3/VS</b>	2	2	SC65BAE-■22	<b>SC-N3RM/VS</b>	4	4	SC65BRE-■22
22	40	80	80	135						<b>SC-N4/VS</b>	1	2	SC80BAE-■12	<b>SC-N4RM/VS</b>	2	4	SC80BRE-■12
30	55	105	105	150						<b>SC-N5/VS</b>	1	2	SC93BAE-■12	<b>SC-N5RM/VS</b>	2	4	SC93BRE-■12
37	60	125	125	150						<b>SC-N6/VS</b>	1	2	SC1CBAE-■12	<b>SC-N6RM/VS</b>	2	4	SC1CBRE-■12
45	75	150	150	200						<b>SC-N7/VS</b>	1	2	SC1FBAE-■12	<b>SC-N7RM/VS</b>	2	4	SC1FBRE-■12
55	90	180	180	260						<b>SC-N8/VS</b>	1	2	SC1JBAE-■12	<b>SC-N8RM/VS</b>	2	4	SC1JBRE-■12
65	110	220	220	260						<b>SC-N10/VS</b>	1	2	SC2CBAE-■12	<b>SC-N10RM/VS</b>	2	4	SC2CBRE-■12
90	160	300	300	350						<b>SC-N11/VS</b>	1	2	SC3ABAE-■12	<b>SC-N11RM/VS</b>	2	4	SC3ABRE-■12
120	220	400	400	450						<b>SC-N12/VS</b>	1	2	SC4ABAE-■12	<b>SC-N12RM/VS</b>	2	4	SC4ABRE-■12
180	315	600	600	660						<b>SC-N14/VS</b>	1	2	SC6ABAE-■12	<b>SC-N14RM/VS</b>	2	4	SC6ABRE-■12

Notes: Since SC-N1/VS to SC-N14/VS are provided with the SUPER MAGNET they operate on both AC or DC. Enter the coil rated voltage code in the ■ mark, see page 01/27

##### • DC operated

Max. motor capacity (kW)						Rated operational current (A)			Rated thermal current Ith (A)	Non-reversing			Reversing				
200V	380V	200V	380V	240V	440V	200V	380V	240V		440V	Type	Aux. contact NO	NC	Ordering code	Type	Aux. contact NO	NC
2.5	4	11	9	20						<b>SC-03/VG</b>	–	–	SC11AD-■00	<b>SC03RM/VG</b>	–	–	SC11RD-■00
3.5	5.5	13	12	20						<b>SC-0/VG</b>	–	–	SC13AD-■00	<b>SC0RM/VG</b>	–	–	SC13RD-■00
3.5	5.5	13	12	20						<b>SC-05/VG</b>	1	–	SC14AD-■10	<b>SC05RM/VG</b>	2	–	SC14RD-■10
3.5	5.5	13	12	20							–	1	SC14AD-■01		–	2	SC14RD-■01
4.5	7.5	18	16	25						<b>SC-4-0/VG</b>	–	–	SC18AD-■00	<b>SC-4-0RM/VG</b>	–	–	SC18RD-■00
5.5	11	22	22	32						<b>SC-4-1/VG</b>	–	–	SC19AD-■00	<b>SC-4-1RM/VG</b>	–	–	SC19RD-■00
5.5	11	22	22	32						<b>SC-5-1/VG</b>	1	–	SC20AD-■10	<b>SC-5-1RM/VG</b>	2	–	SC20RD-■10
5.5	11	22	22	32							–	1	SC20AD-■01		–	2	SC20RD-■01
5.5	11	22	22	32							1	2	SC20AD-■12		2	4	SC20RD-■12

Note: Enter the coil rated voltage code in the ■ mark, see page 01/27

■ **Operating method**

**Closing**

When the closing coil is energized the latch mechanism interlocks to latch and the NC contact connected in series with the closing coil opens and the coil is de-energized.

**Tripping**

When the tripping coil is energized the latch is released and tripping is carried out by means of the back spring. At this time the NO contact connected in series with the tripping coil opens.

■ **Operating notes**

- When carrying out a sequence operating check make sure that the load circuit is open.
- The electrical signal time for closing and tripping should be 0.3 sec. or more.
- Tripping coil is short time rated. Tripping coil: Max. 15 seconds
- In the cases of 03/V to N3/VS versions the contacts cannot be replaced. In the cases of those versions above N4/VS the contacts can be replaced.
- Both closing and tripping circuits should be electrically interlocked with each other.

■ **Ordering information**

Specify the following:

1. Ordering code
2. Auxiliary contact arrangement: In the case of the frame size 05/V, 05/VG, 5-1/V or 5-1/VG, specify the contact arrangement.
3. Closing and tripping coil  
 For AC operated: Voltage and frequency  
 For DC operated: Voltage

■ **Coil characteristics**

**AC operated**

Type	Power consumption		Coil voltage *
	Closing (VA)	Tripping (VA)	
SC-03/V	95	150	100/100–110V AC 50/60Hz
SC-0/V	95	150	
SC-05/V	95	150	
SC-4-0/V	95	150	
SC-4-1/V	95	150	
SC-5-1/V	95	150	200/200–220V AC 50/60Hz
SC-N1/VS	100	140	
SC-N2/VS	100	140	
SC-N2S/VS	115	140	
SC-N3/VS	115	140	
SC-N4/VS	161	266	
SC-N5/VS	161	266	
SC-N6/VS	229	266	200/220V AC 50/60Hz
SC-N7/VS	229	266	
SC-N8/VS	273	385	
SC-N10/VS	273	385	
SC-N11/VS	490	385	
SC-N12/VS	490	385	
SC-N14/VS	500	660	

**DC operated**

Type	Power consumption		Coil voltage *
	Closing (W)	Tripping (W)	
SC-03/VG	7	150	100, 110V DC
SC-0/VG	7	150	
SC-05/VG	7	150	
SC-4-0/VG	7	150	200, 220V DC
SC-4-1/VG	7	150	
SC-5-1/VG	7	150	
SC-N1/VS	95	150	
SC-N2/VS	95	150	
SC-N2S/VS	110	150	200–220V DC
SC-N3/VS	110	150	
SC-N4/VS	153	198	
SC-N5/VS	153	198	100–110V DC
SC-N6/VS	216	198	
SC-N7/VS	216	198	
SC-N8/VS	260	294	
SC-N10/VS	260	294	
SC-N11/VS	515	294	
SC-N12/VS	515	294	
SC-N14/VS	500	660	

Notes: \*Other coil voltage can be supplied.  
 SC-03/V to 5-1/V: 24 to 220V AC 50/60Hz  
 SC-N1/VS to N12/VS: 24 to 220V AC 50/60Hz  
 SC-N14/VS: 100 to 220V AC 50/60Hz

Notes: \*Other coil voltage can be supplied.  
 SC-03/VG to 5-1/VG: 24 to 220V DC  
 SC-N1/VS to N12/VS: 24 to 220V DC  
 SC-N14/VS: 100 to 220V DC

■ **Operating circuit**

SC-03/V to 5-1/V  
 SC-03/VG to 5-1/VG

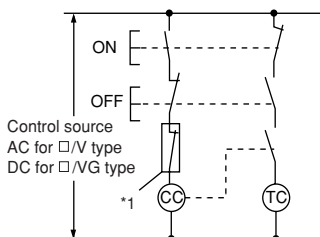

\*1 NC contact for closing coil to be de-energized

SC-N1/VS to N3/VS

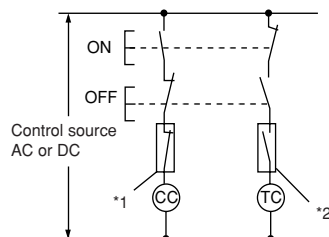

\*1 NC contact for closing coil to be de-energized.  
 \*2 NO contact for tripping coil to be de-energized.

SC-N4/VS to N14/VS

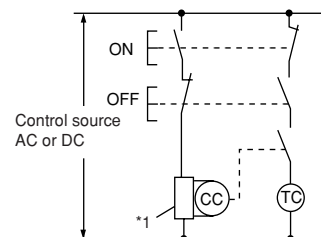

\*1 Solid-state circuit for closing coil to be controlled. (NC solid-state contact)

# Magnetic Contactors

## SC series

### Mechanical latch

#### Mechanical latch type contactors

##### ■ Dimensions, mm

SC-03/V to 5-1/V  
SC-03/VG to 5-1/VG

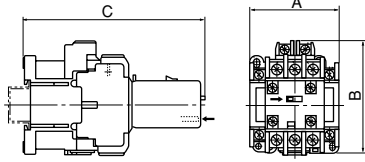

SC-N4/VS to N7/VS

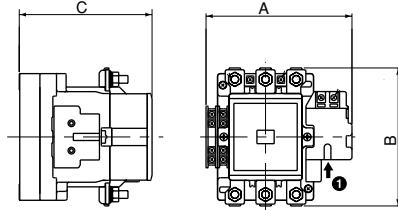

SC-N14/VS

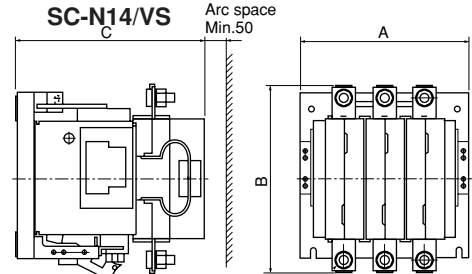

SC-N1/VS to N3/VS

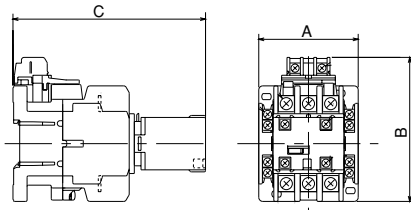

SC-N8/VS to N12/VS

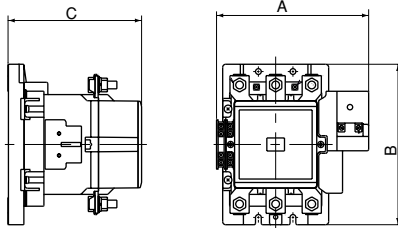

Dimensions for reference only.  
Confirm before construction begins.

Type	A	B	C	Mass (kg)
SC-03/V, 0/V	43	81	128	0.43
SC-05/V	53	81	128	0.45
SC-4-0/V, 4-1/V	53	81	129	0.47
SC-5-1/V	64	81	129	0.49
SC-03/VG, 0/VG	43	81	155	0.66
SC-05/VG	53	81	155	0.69
SC-4-0/VG, 4-1/VG	53	81	156	0.71
SC-5-1/VG	64	81	156	0.73

Type	A	B	C	Mass (kg)
SC-N1/VS, N2/VS	74	108	143.5	0.75
SC-N2S/VS, N3/VS	88	130	158	1.25
SC-N4/VS, N5/VS	140	127	132	2.3
SC-N6/VS	152	144	138	2.9
SC-N7/VS	167.5	156	140	3.2
SC-N8/VS, N10/VS	199	209	174	5.7
SC-N11/VS, N12/VS	215.5	240	195	8.6
SC-N14/VS	290	332	331	37

##### ■ Wiring diagrams

SC-03/V, 0/V, 4-0/V, 4-1/V  
SC-03/VG, 0/VG, 4-0/VG, 4-1/VG

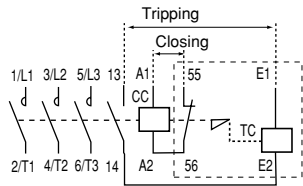

SC-5-1/V, /VG (Aux. contact 1NO+2NC)

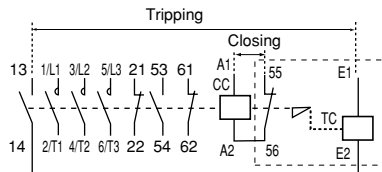

SC-N14/VS

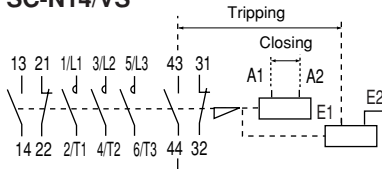

SC-05/V, 5-1/V SC-05/VG, 5-1/VG  
(Aux. contact 1NO)

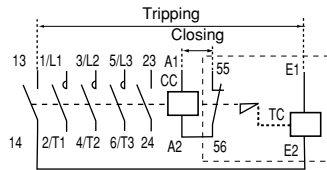

SC-N1/VS to N3/VS

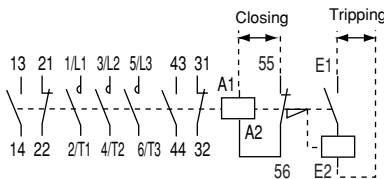

(Aux. contact 1NC)

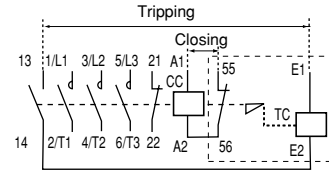

SC-N4/VS to N12/VS

CC: Closing coil  
TC: Tripping coil

Reversing mechanical latch contactors

■ Dimensions, mm  
SC-03RM/V to 5-1RM/V  
SC-03RM/VG to 5-1RM/VG

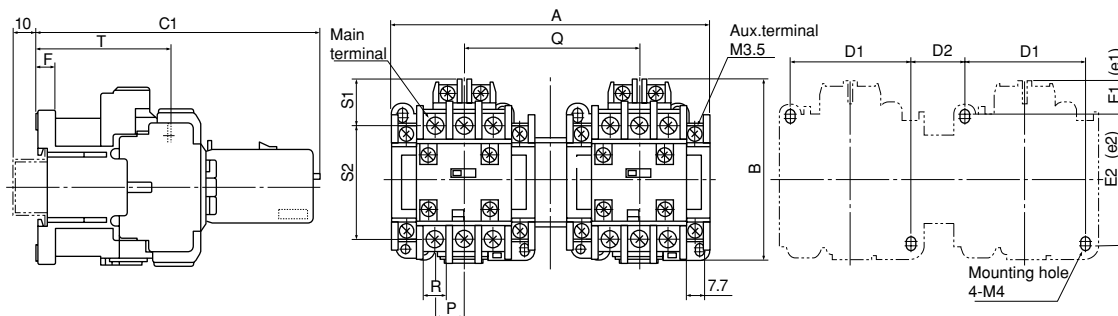

Type	Auxiliary contact	A	B	C1	D1	D2	E1(e <sub>1</sub> )	E2(e <sub>2</sub> )	F	P	Q	R	S1	S2	T	Main terminal	Mass (kg)
SC-03RM/V	—	99	81	128	34	22	18.5 (20.5)	52 (48)	8.5	10	56	7.7	23	43	61	M3.5	0.9
SC-0RM/V	—	99	81	128	34	22	18.5 (20.5)	52 (48)	8.5	10	56	7.7	23	43	61	M3.5	0.9
SC-05RM/V	2NO or 2NC	119	81	128	34	32	18.5 (20.5)	52 (48)	8.5	10	66	7.7	23	43	61	M3.5	0.94
SC-4-0RM/V	—	119	81	129	34	32	18.5 (20.5)	52 (48)	8.5	13	66	9.7	20	49	61	M4	0.98
SC-4-1RM/V	—	119	81	129	34	32	18.5 (20.5)	52 (48)	8.5	13	66	9.7	20	49	61	M4	0.98
SC-5-1RM/V	2NO or 2NC	141	81	129	54	23	14.5 (16.5)	60 (56)	8.5	13	77	9.7	20	49	61	M4	1.02
	2NO+4NC	165	81	129	54	23	14.5 (16.5)	60 (56)	8.5	13	77	9.7	20	49	61	M4	1.08
SC-03RM/VG	—	99	81	155	34	22	18.5 (20.5)	52 (48)	8.5	10	56	7.7	23	43	88	M3.5	1.36
SC-0RM/VG	—	99	81	155	34	22	18.5 (20.5)	52 (48)	8.5	10	56	7.7	23	43	88	M3.5	1.36
SC-05RM/VG	2NO or 2NC	119	81	155	34	32	18.5 (20.5)	52 (48)	8.5	10	66	7.7	23	43	88	M3.5	1.42
SC-4-0RM/VG	—	119	81	156	34	32	18.5 (20.5)	52 (48)	8.5	13	66	9.7	20	49	88	M4	1.46
SC-4-1RM/VG	—	119	81	156	34	32	18.5 (20.5)	52 (48)	8.5	13	66	9.7	20	49	88	M4	1.46
SC-5-1RM/VG	2NO or 2NC	141	81	156	54	23	14.5 (16.5)	60 (56)	8.5	13	77	9.7	20	49	88	M4	1.5
	2NO+4NC	165	81	156	54	23	14.5 (16.5)	60 (56)	8.5	13	77	9.7	20	49	88	M4	1.56

Fig. 1 SC-N1RM/VS to N3RM/VS

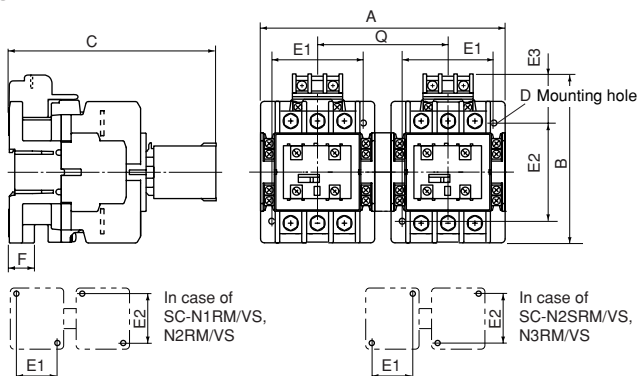

Fig. 2 SC-N4RM/VS to N12RM/VS

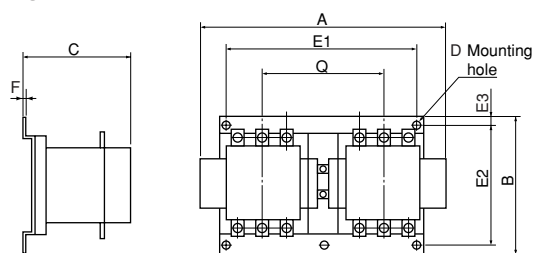
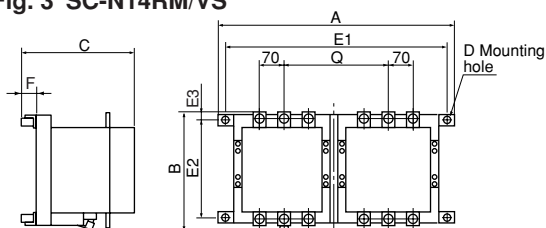

Fig. 3 SC-N14RM/VS



Type	A	B	C	D	E1	E2	E3	F	Q	Mass (kg)	Fig. No.
SC-N1RM/VS	161	108	143.5	4-M4	65	70	30	10.5	87	1.6	1
SC-N2RM/VS	161	108	143.5	4-M4	65	70	30	10.5	87	1.6	1
SC-N2SRM/VS	187	130	158	4-M4	70	75	38	10.5	100	2.6	1
SC-N3RM/VS	187	130	158	4-M4	70	75	38	10.5	100	2.6	1
SC-N4RM/VS	303	165	122	3-M5	200	150	7.5	1.6	135	5.0	2
SC-N5RM/VS	303	165	122	3-M5	200	150	7.5	1.6	135	5.0	2
SC-N6RM/VS	327	190	145	3-M5	220	175	7.5	1.6	147	6.7	2
SC-N7RM/VS	358	215	147	3-M6	260	200	7.5	2	162	8.1	2
SC-N8RM/VS	421	270	184	4-M6	300	250	10	2	177	13.0	2
SC-N10RM/VS	421	270	184	4-M6	300	250	10	2	177	13.0	2
SC-N11RM/VS	454	330	210	4-M8	300	300	15	2.3	192	21.4	2
SC-N12RM/VS	454	330	210	4-M8	300	300	15	2.3	192	21.4	2
SC-N14RM/VS	700	349	376	4-M10	650	250	41	45	324	80	3

Dimensions for reference only.  
Confirm before construction begins.

# Magnetic Contactors

## SC series

### Mechanical latch

#### Reversing mechanical latch contactors

##### ■ Wiring diagrams

SC-03RM/V, 0RM/V, 4-0RM/V, 4-1RM/V

SC-03RM/VG, 0RM/VG, 4-0RM/VG, 4-1RM/VG

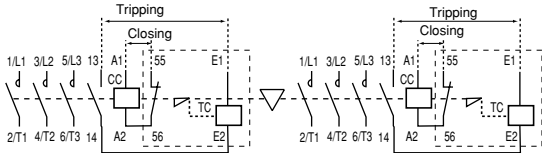

CC: Closing coil  
TC: Tripping coil

SC-05RM/V, 5-1RM/V  
SC-05RM/VG, 5-1RM/VG  
Auxiliary contact: 1NC×2

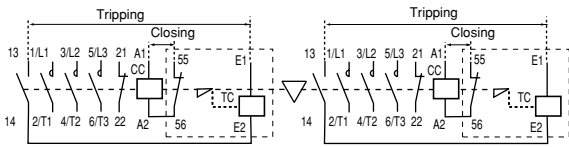

CC: Closing coil  
TC: Tripping coil

SC-N1RM/VS to N3RM/VS

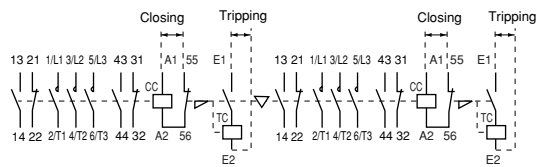

CC: Closing coil  
TC: Tripping coil

SC-N14RM/VS

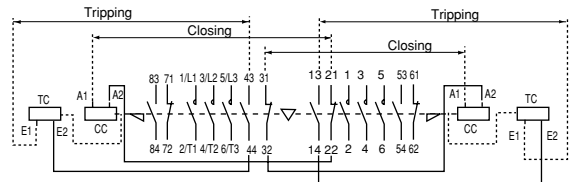

CC: Closing coil  
TC: Tripping coil

SC-05RM/V, 5-1RM/V

SC-05RM/VG, 5-1RM/VG

Auxiliary contact: 1NO×2

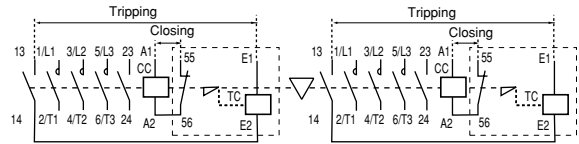

CC: Closing coil  
TC: Tripping coil

SC-5-1RM/V  
SC-5-1RM/VG  
Auxiliary contact: 2×(1NO+2NC)

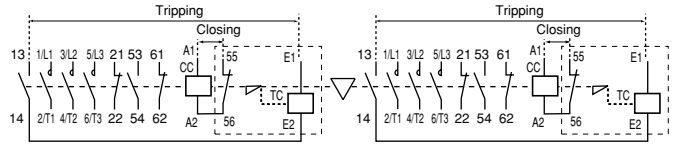

CC: Closing coil  
TC: Tripping coil

SC-N4RM/VS to N12RM/VS

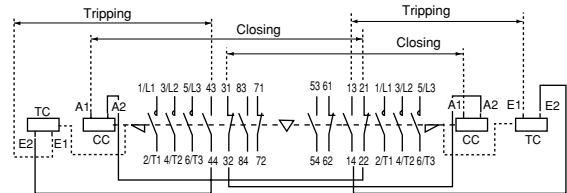

CC: Closing coil  
TC: Tripping coil

## Motor starters for heavy starting duty conditions

Up to 315kW 440 Volts 3-phase

### Description

This starter is designed for applications to those loads where the inrush current at the moment of starting persists for a long period, such as with blowers, winders, fans and centrifugal separators whose inertia force is large. In these cases the inrush current could last up to 7-8 sec., and would cause a standard type starter to misstrip. FUJI heavy load starters are highly suitable for such conditions and are provided with long time operating type thermal overload relays. In this type of

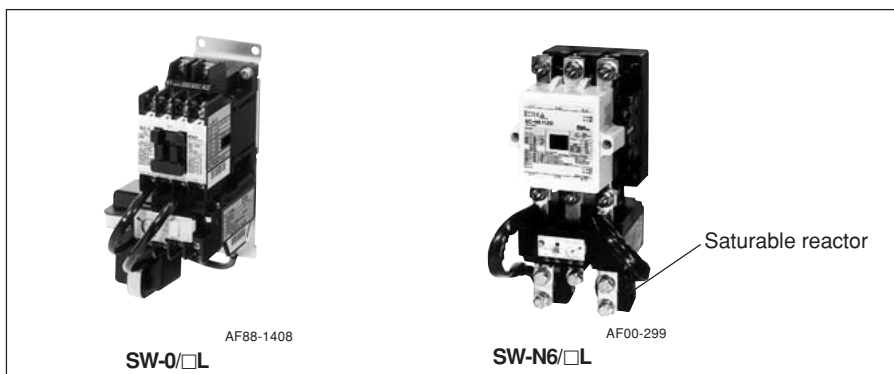

overload relay the small-sized saturable core reactors are connected in parallel with the heater elements. These divert the inrush current at the time of starting.

### Ordering information

Specify the following:

1. Ordering code
2. Overload relay setting range code
3. Operating coil voltage code
4. Auxiliary contact arrangement

### Types and ratings

Type	Ordering code	Aux. contact		Max. motor capacity (kW)		Operational current (A)		Combined thermal overload relay (3-element) Type
		NO	NC	200V 240V	380V 440V	200V 240V	380V 440V	
SW-03/3L	SC11AAF-■10T□	1	–	2.5	4	11	9	TR-0NL/3
SW-03/3L	SC11AAF-■01T□	–	1	2.5	4	11	9	TR-0NL/3
SW-0/3L	SC13AAF-■10T□	1	–	3.5	5.5	13	12	TR-0NL/3
SW-0/3L	SC13AAF-■01T□	–	1	3.5	5.5	13	12	TR-0NL/3
SW-05/3L	SC14AAF-■20T□	2	–	3.5	5.5	13	12	TR-0NL/3
SW-05/3L	SC14AAF-■11T□	1	1	3.5	5.5	13	12	TR-0NL/3
SW-05/3L	SC14AAF-■02T□	–	2	3.5	5.5	13	12	TR-0NL/3
SW-4-0/3L	SC18AAF-■10T□	1	–	4.5	7.5	18	16	TR-5-1NL/3
SW-4-0/3L	SC18AAF-■01T□	–	1	4.5	7.5	18	16	TR-5-1NL/3
SW-4-1/3L	SC19AAF-■10T□	1	–	5.5	11	22	22	TR-5-1NL/3
SW-4-1/3L	SC19AAF-■01T□	–	1	5.5	11	22	22	TR-5-1NL/3
SW-5-1/3L	SC20AAF-■20T□	2	–	5.5	11	22	22	TR-5-1NL/3
SW-5-1/3L	SC20AAF-■11T□	1	1	5.5	11	22	22	TR-5-1NL/3
SW-5-1/3L	SC20AAF-■02T□	–	2	5.5	11	22	22	TR-5-1NL/3
SW-5-1/3L	SC20AAF-■22T□	2	2	5.5	11	22	22	TR-5-1NL/3
SW-N1/3L	SC25BAAF-■22T□	2	2	7.5	15	32	32	TR-N2L/3
SW-N2/3L	SC35BAAF-■22T□	2	2	11	18.5	40	40	TR-N2L/3
SW-N2S/3L	SC50BAAF-■22T□	2	2	15	22	50	50	TR-N3L/3
SW-N3/3L	SC65BAAF-■22T□	2	2	18.5	30	65	65	TR-N3L/3
SW-N4/3L	SC80BAAF-■22T□	2	2	22	40	80	80	TR-N5L/3
SW-N5/3L	SC93BAAF-■22T□	2	2	30	55	105	105	TR-N5L/3
SW-N6/3L	SC1CBAAF-■22T□	2	2	37	60	125	125	TR-N6L/3
SW-N7/3L	SC1FBAAF-■22T□	2	2	45	75	150	150	TR-N7L/3
SW-N8/3L	SC1JBAAF-■22T□	2	2	55	90	180	180	TR-N10L/3
SW-N10/3L	SC2CBAAF-■22T□	2	2	65	110	220	220	TR-N10L/3
SW-N11/3L	SC3ABAAF-■22T□	2	2	90	160	300	300	TR-N11L/3
SW-N12/3L	SC4ABAAF-■22T□	2	2	120	220	400	400	TR-N12L/3
SW-N14/3L	SC6ABAAF-■22T□	2	2	180	315	600	600	TR-N14L/3

- Notes: 1. ■ Enter the operating coil voltage code.  
2. □ Enter the thermal overload relay ampere setting range code.  
3. Starters with 2-element overload relay are also available SW-□/2L.

# Magnetic Motor Starters

## SW series

### Heavy starting duty

#### ■ Dimensions, mm

SW-03/2L to 5-1/2L  
SW-03/3L to 5-1/3L

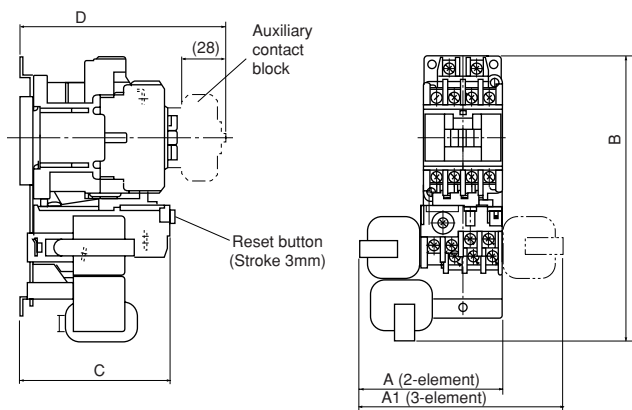

Type	2-element	3-element	A	A1	B	C	D *	Mass (kg)	
								2-element	3-element
SW-03/2L	SW-03/3L		79	115	157	83	113	0.62	0.72
SW-0/2L	SW-0/3L		79	115	157	83	113	0.62	0.72
SW-05/2L	SW-05/3L		84	120	157	84	114	0.64	0.74
SW-4-0/2L	SW-4-0/3L		88	124	157	83	114	0.66	0.76
SW-4-1/2L	SW-4-1/3L		88	124	157	83	114	0.66	0.76
SW-5-1/2L	SW-5-1/3L		89	124	157	83	114	0.69	0.79
SW-5-1/2L	SW-5-1/3L		89	124	157	83	114	0.71	0.81

C: Without front mounting auxiliary contact block

D: With front mounting auxiliary contact block

\* Mounted auxiliary contacts 2NO+2NC

#### SW-N1/2L, N2/2L SW-N1/3L, N2/3L

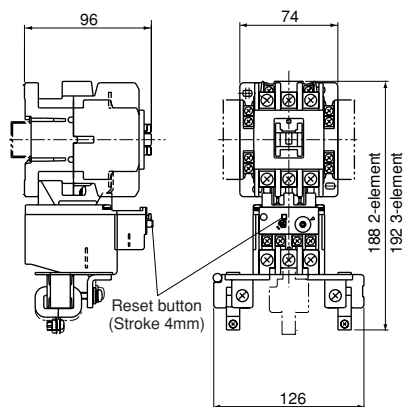

Mass: SW-N1/2L, N2/2L: 1.01kg  
SW-N1/3L, N2/3L: 1.13kg

#### SW-N2S/2L to SW-N7/2L SW-N2S/3L to SW-N7/3L

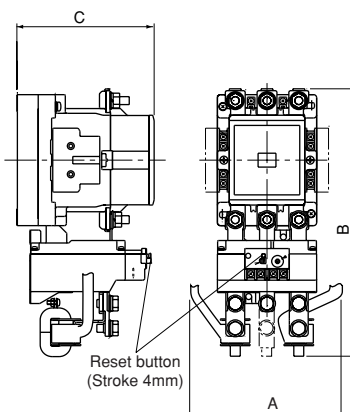

#### SW-N8/2L SW-N8/3L

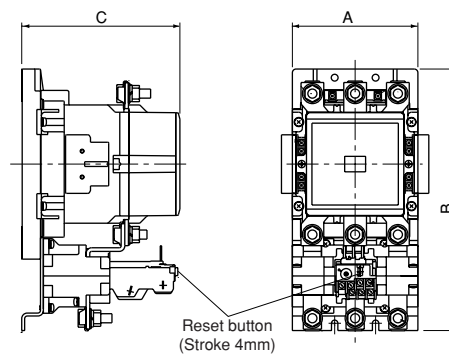

Note: SW-N10/2L, N11/2L, N12/2L and N14/2L,  
SW-N10/3L, N11/3L, N12/3L and N14/3L,  
N11/3H, N12/3H and N14/3H, respectively.

Type	2-element	3-element	A	B	C	Mass (kg)		
				2-element	3-element	2-element	3-element	
SW-N2S/2L	SW-N2S/3L		138	219	219	111	1.54	1.66
SW-N3/2L	SW-N3/3L		138(149)*	219(202)*	219(224)*	111	1.54	1.64
SW-N4/2L	SW-N4/3L		138(149)*	230(214)*	230(236)*	117	2.26	2.54
SW-N5/2L	SW-N5/3L		149	214	236	132	2.66	2.94
SW-N6/2L	SW-N6/3L		165	270	270	138	3.62	3.93
SW-N7/2L	SW-N7/3L		165	281	281	140	3.92	4.23
SW-N8/2L	SW-N8/3L		138	287	287	174	6.8	6.8

\*( ) = In case of ampere setting range 45 to 65A

Dimensions for reference only. Confirm before construction begins.

**Motor starters with quick operating thermal overload relay**

Up to 55kW 440 Volts 3-phase

**Description**

This motor starter is fitted with a quick operating type thermal overload relay which makes suitable for controlling submersible motor pumps and compressors. These motor windings are cooled by using liquid or other media.

Thus their overload capacity will be less than standard type motor. This also means that these motors cannot be protected by standard type overload relays since their operation would be rather slow. The starters are available in types ranging from SW-03/3Q to SW-N5/3Q. All thermal overload relays have 3-heater elements.

**Features**

- Thermal overload relays are designed to have similar starting characteristics to those of the motors. These relays will operate quicker than the standard type in the face of a locked rotor current. (Refer to the graph.)
- Compact with external dimensions similar to the standard type.
- The ampere setting dial of the overload relays is calibrated to an RC scale (Rated current). All that is necessary is to set a value equal to the full load current of the motor.

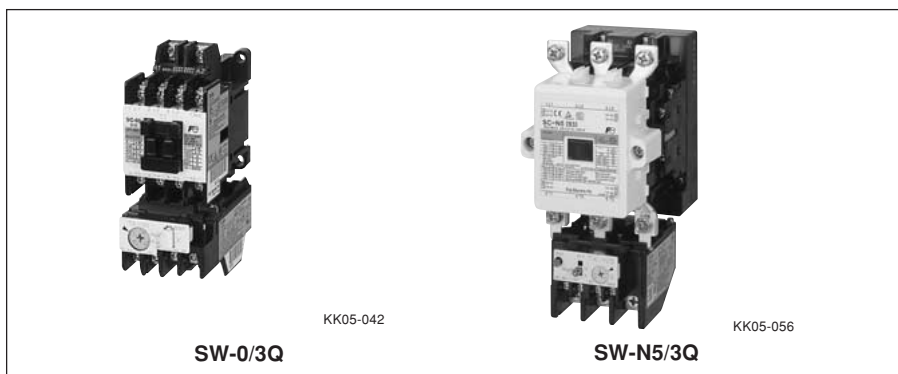

**Operating characteristics**

For explanation only

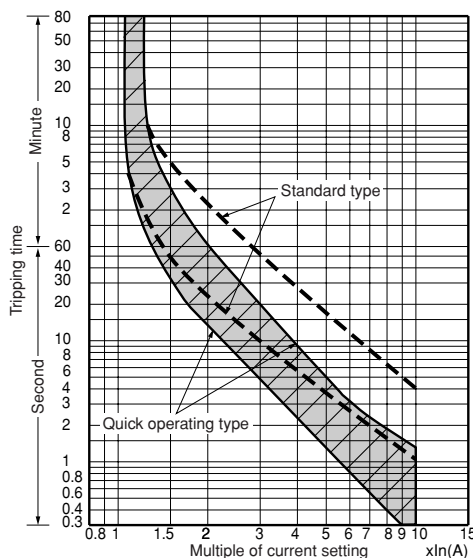

**Ordering information**

Specify the following:

1. Ordering code
2. Overload relay setting range code
3. Operating coil voltage code
4. Auxiliary contact arrangement

**Performance data:**

Same as standard types  
See page 01/30.  
Conforming to Class AC-3, IEC60947-4-1.

**Ratings of coil and auxiliary contact:**

See pages 01/28, 30 and 31.

**Dimensions and wiring diagrams:**

Same as standard types  
See page 01/37, 38 and 39.

**Thermal overload relay:**

See page 01/97.

**Ratings**

Type	Ordering code	Max. motor capacity (kW)		Rated operational current (A)		Auxiliary contact		Combined thermal overload relay	
		200V 240V	380V 440V	200V 240V	380V 440V	NO	NC	Type	Ordering code
SW-03/3Q	SC11AAS-■10T□	2.5	4	11	9	1	- *1	TR-0NQ	TR13SW-□
SW-0/3Q	SC13AAS-■10T□	3.5	5.5	13	12	1	- *1	TR-0NQ	TR13SW-□
SW-05/3Q	SC14AAS-■11T□	3.5	5.5	13	12	1	1 *2	TR-0NQ	TR13SW-□
SW-4-0/3Q	SC18AAS-■10T□	4.5	7.5	18	16	1	- *1	TR-5-1NQ	TR20SW-□
SW-4-1/3Q	SC19AAS-■10T□	4.5	7.5	18	16	1	- *1	TR-5-1NQ	TR20SW-□
SW-5-1/3Q	SC20AAS-■11T□	4.5	7.5	18	16	1	1 *3	TR-5-1NQ	TR20SW-□
SW-5-1/3Q	SC20AAS-■22T□	4.5	7.5	18	16	2	2	TR-5-1NQ	TR20SW-□
SW-N1/3Q	SC25BAAS-■22T□	7.5	15	32	32	2	2	TR-N2Q	TR35BSW-□
SW-N2/3Q	SC35BAAS-■22T□	11	18.5	40	40	2	2	TR-N2Q	TR35BSW-□
SW-N2S/3Q	SC50BAAS-■22T□	15	22	50	50	2	2	TR-N3Q	TR65BSW-□
SW-N3/3Q	SC65BAAS-■22T□	18.5	30	65	65	2	2	TR-N3Q	TR65BSW-□
SW-N4/3Q	SC80BAAS-■22T□	22	40	80	80	2	2	TR-N5Q	TR80BSW-□
SW-N5/3Q	SC93BAAS-■22T□	30	55	105	105	2	2	TR-N5Q	TR1CBSW-□

Notes: \*1 Auxiliary contact 1NC is also available on request.  
\*2 Auxiliary contact 2NO or 2NC is also available on request.  
\*3 Auxiliary contact 2NO, 2NC or 2NO+2NC is also available on request.  
Enter the coil voltage code in the ■ mark.  
Enter the thermal overload relay ampere setting range code in the □ mark.

# Magnetic Motor Starters

## SW series

### With phase-loss protective device

#### Motor starters with phase-loss protective device

Up to 315 kW 440 Volts 3-phase

##### ■ Description

These starters are provided with a FUJI TK type thermal overload relay. This has an phase-loss protection function as well as the ordinary overload protection.

These devices prevent damage due to single-phasing such as fuse melting, cable troubles or loosening through excessive vibration.

They are highly suitable for such applications as cooling fans or circulating pumps for power transformers.

The switches use FUJI SC series contactors which have a life expectancy of over 1 million operations and which makes them suitable for motor controls for industrial use.

Size range from 03 to N14 with capacities from 2.5kW to 180kW 220 Volts AC. Starters are available in both open- and enclosed-type versions.

Reversing motor starters with TK relays are also available.

##### ■ Ordering information

Specify the following:

1. Ordering code
2. Overload relay setting range code
3. Operating coil voltage code
4. Auxiliary contact arrangement

##### ■ Performance data:

Same as standard types.

See page 01/30.

##### ■ Ratings of coil and auxiliary contacts:

See pages 01/28, 30 and 31.

##### ■ Dimensions and wiring diagrams:

See pages 01/37, 38, 39 and 40.

##### ■ Characteristics of TK relay:

See page 01/109.

##### ■ Thermal overload relays with phase-loss protection

The TK thermal overload relay perfectly matches the heat characteristics of 3-phase squirrel-cage induction motors. The heater element and phase-loss protective mechanism are built inside the enclosure.

The characteristics of the phase-loss



mechanism co-ordinate with the temperature rise curve of the stator winding at the time of phase-loss. When an phase-loss is produced during the full load operation of a 3-phase motor a current larger than the full load current will flow and operate the thermal overload relay.

Under this load condition the standard type OL relay can provide adequate protection. If the load is approx. 60% of the full load current the motor will continue a single phase running and the line current will become almost equal to the full load current.

However, since it will not reach the minimum operating point of OL relay the starter will not be tripped.

In the case of a delta winding motor a phase current of approx. 115% of the line full load current will flow in windings. This overcurrent results in a temperature rise in the motor windings and damage due to overheating can be expected.

FUJI TK thermal overload relays are provided with ADL mechanism which can correctly detect phase-loss under such medium load conditions. This sophisticated detecting mechanism can take corrective action quicker in the case of overload running.

The ADL mechanism operates on a dependable and simple level design. It works as follows:—

The heater, in phase-loss, will be cool since no load current flows, while heater of other phases will heat up since a large current flows.

The difference in temperature between the cold and hot heater elements causes the shift lever to operate the Trip/Alarm contact.

The operating current range is 105%–120% of the rated current set on the dial.

#### Reversing motor starter with phase-loss protective device

##### ■ Description

This reversing motor starter uses two contactors and TK type thermal overload relay. The TK relay is provided with a heater element and a built-in mechanism for phase-loss protection use, which match with the thermal characteristics of 3-phase squirrel-cage rotor motor. This eliminates the possibility of damage in the case of the motor overheating.

The TK relay also features manual tripping, a trip-free mechanism, MANUAL/AUTO selector lever, wide range dial ampere adjustment, ambient temperature compensator and 1NO•1NC trip/alarm contact, etc. Starters can be supplied with either open type or provided with enclosures. The general purpose enclosure is made of pressed steel and is not provided with a pushbutton.

■ Types and ratings/Non-reversing

Max. motor capacity (kW)		Operational current (A)		Auxiliary contact	Open Type	Ordering code	Enclosed Type	Ordering code	Combined thermal overload relay
200V	380V	200V	380V	Standard					
240V	440V	240V	440V						
2.5	4	11	9	1NO *1	SW-03/2E	SC11AAE-■10T□	SW-03C/2E	SC11CAE-■10T□	TK-0N
3.5	5.5	13	12	1NO *1	SW-0/2E	SC13AAE-■10T□	SW-0C/2E	SC13CAE-■10T□	TK-0N
3.5	5.5	13	12	1NO+1NC *2	SW-05/2E	SC14AAE-■11T□	SW-05C/2E	SC14CAE-■11T□	TK-0N
4.5	7.5	18	16	1NO *1	SW-4-0/2E	SC18AAE-■10T□	SW-4-0C/2E	SC18CAE-■10T□	TK-5-1N
5.5	11	22	22	1NO *1	SW-4-1/2E	SC19AAE-■10T□	SW-4-1C/2E	SC19CAE-■10T□	TK-5-1N
5.5	11	22	22	1NO+1NC *3	SW-5-1/2E	SC20AAE-■11T□	SW-5-1C/2E	SC20CAE-■11T□	TK-5-1N
7.5	15	32	32	2NO+2NC *4	SW-N1/2E	SC25BAAE-■22T□	SW-N1C/2E	SC25CAE-■22T□	TK-N2
11	18.5	40	40	2NO+2NC *4	SW-N2/2E	SC35BAAE-■22T□	SW-N2C/2E	SC35CAE-■22T□	TK-N2
15	22	50	50	2NO+2NC *4	SW-N2S/2E	SC50BAAE-■22T□	SW-N2SC/2E	SC50CAE-■22T□	TK-N3
18.5	30	65	65	2NO+2NC *4	SW-N3/2E	SC65BAAE-■22T□	SW-N3C/2E	SC65CAE-■22T□	TK-N3
22	40	80	80	2NO+2NC *4	SW-N4/2E	SC80BAAE-■22T□	SW-N4C/2E	SC80CAE-■22T□	TK-N5
30	55	105	105	2NO+2NC *4	SW-N5/2E	SC93BAAE-■22T□	SW-N5C/2E	SC93CAE-■22T□	TK-N5
37	60	125	125	2NO+2NC *4	SW-N6/2E	SC1CBAAE-■22T□	SW-N6C/2E	SC1CCAE-■22T□	TK-N6
45	75	150	150	2NO+2NC *4	SW-N7/2E	SC1FBAAE-■22T□	SW-N7C/2E	SC1FCAE-■22T□	TK-N7
55	90	180	180	2NO+2NC *4	SW-N8/2E	SC1JBAAE-■22T□	SW-N8C/2E	SC1JCAE-■22T□	TK-N8
65	110	220	220	2NO+2NC *4	SW-N10/2E	SC2CBAAE-■22T□	SW-N10C/2E	SC2CCAE-■22T□	TK-N10
90	160	300	300	2NO+2NC *4	SW-N11/2E	SC3ABAAE-■22T□	SW-N11C/2E	SC3ACAE-■22T□	TK-N11
120	220	400	400	2NO+2NC *4	SW-N12/2E	SC4ABAAE-■22T□	SW-N12C/2E	SC4ACAE-■22T□	TK-N12
180	315	600	600	2NO+2NC *4	SW-N14/2E	SC6ABAAE-■22T□	SW-N14C/2E	SC6ACAE-■22T□	TK-N14

Notes: Enter the coil voltage code in the ■ mark.  
Enter the thermal overload relay ampere setting range code in the □ mark.  
\*1 Auxiliary contact 1NC is available on request.  
\*2 Auxiliary contact 2NO or 2NC is available on request.  
\*3 Auxiliary contact 2NO, 2NC or 2NO+2NC is available on request. However, 2NO+2NC is not available for enclosed types.  
\*4 Auxiliary contact 4NO+4NC is available on request for frame sizes N1 and above.

■ Types and ratings/Reversing

Max. motor capacity (kW)		Operational current (A)		Auxiliary contact	Open Type	Ordering code	Enclosed Type	Ordering code	Combined thermal overload relay
200V	380V	200V	380V	Standard					
240V	440V	240V	440V						
2.5	4	11	9	1NC × 2 *1	SW-03RM/2E	SC11RAE-■01T□	SW-03RMC/2E	SC11MAE-■01T□	TK-0N
3.5	5.5	13	12	1NC × 2 *1	SW-0RM/2E	SC13RAE-■01T□	SW-0RMC/2E	SC13MAE-■01T□	TK-0N
3.5	5.5	13	12	(1NO+1NC) × 2 *2	SW-05RM/2E	SC14RAE-■11T□	SW-05RMC/2E	SC14MAE-■11T□	TK-0N
4.5	7.5	18	16	1NC × 2 *1	SW-4-0RM/2E	SC18RAE-■01T□	SW-4-0RMC/2E	SC18MAE-■01T□	TK-5-1N
5.5	11	22	22	1NC × 2 *1	SW-4-1RM/2E	SC19RAE-■01T□	SW-4-1RMC/2E	SC19MAE-■01T□	TK-5-1N
5.5	11	22	22	(1NO+1NC) × 2 *3	SW-5-1RM/2E	SC20RAE-■11T□	SW-5-1RMC/2E	SC20MAE-■11T□	TK-5-1N
7.5	15	32	32	(2NO+2NC) × 2 *4	SW-N1RM/2E	SC25BRAE-■22T□	SW-N1RMC/2E	SC25BMAE-■22T□	TK-N2
11	18.5	40	40	(2NO+2NC) × 2 *4	SW-N2RM/2E	SC35BRAE-■22T□	SW-N2RMC/2E	SC35BMAE-■22T□	TK-N2
15	22	50	50	(2NO+2NC) × 2 *4	SW-N2SRM/2E	SC50BRAE-■22T□	SW-N2SRMC/2E	SC50BMAE-■22T□	TK-N3
18.5	30	65	65	(2NO+2NC) × 2 *4	SW-N3M/2E	SC65BRAE-■22T□	SW-N3RMC/2E	SC65BMAE-■22T□	TK-N3
22	40	80	80	(2NO+2NC) × 2 *4	SW-N4RM/2E	SC80BRAE-■22T□	SW-N4RMC/2E	SC80BMAE-■22T□	TK-N5
30	55	105	105	(2NO+2NC) × 2 *4	SW-N5RM/2E	SC93BRAE-■22T□	SW-N5RMC/2E	SC93BMAE-■22T□	TK-N5
37	60	125	125	(2NO+2NC) × 2 *4	SW-N6RM/2E	SC1CBRAE-■22T□	SW-N6RMC/2E	SC1CBMAE-■22T□	TK-N6
45	75	150	150	(2NO+2NC) × 2 *4	SW-N7RM/2E	SC1FBRAE-■22T□	SW-N7RMC/2E	SC1FBMAE-■22T□	TK-N7
55	90	180	180	(2NO+2NC) × 2 *4	SW-N8RM/2E	SC1JBRAE-■22T□	SW-N8RMC/2E	SC1JBMAE-■22T□	TK-N8
65	110	220	220	(2NO+2NC) × 2 *4	SW-N10RM/2E	SC2CBRAE-■22T□	SW-N10RMC/2E	SC2CBMAE-■22T□	TK-N10
90	160	300	300	(2NO+2NC) × 2 *4	SW-N11RM/2E	SC3ABRAE-■22T□	SW-N11RMC/2E	SC3ABMAE-■22T□	TK-N11
120	220	400	400	(2NO+2NC) × 2 *4	SW-N12RM/2E	SC4ABRAE-■22T□	SW-N12RMC/2E	SC4ABMAE-■22T□	TK-N12
180	315	600	600	(2NO+2NC) × 2 *4	SW-N14RM/2E	SC6ABRAE-■22T□	SW-N14RMC/2E	SC6ABMAE-■22T□	TK-N14

Notes: Enter the coil voltage code in the ■ mark.  
Enter the thermal overload relay ampere setting range code in the □ mark.  
\*1 Auxiliary contact 1NO×2 is available on request. However, these contactors are not electrically interlocked. Be sure to arrange electrical interlock circuit externally to avoid short-circuit accidents.  
\*2 Auxiliary contact 2NC×2 is available on request.  
\*3 Auxiliary contact 2NC×2 or (2NO+2NC)×2 is available on request. However, (2NO+2NC)×2 is not available for enclosed types.  
\*4 Auxiliary contact (3NO+3NC)×2 is available on request.

# Magnetic Motor Starters

## SW series

### With phase-loss and phase-sequence protective device

#### Motor starters with phase-loss and phase-sequence relays

Up to 315kW 440 Volts 3-phase

#### ■ Description

These starters are fitted with TK type thermal overload relay and phase-sequence relay. The phase-sequence relay only permits engagement of the starter when the phase rotation is confirmed to be correct.

These switches are mainly used for construction site machinery, window shutters, machine tools, compressors, freezers, conveyors, underwater pumps, car washing machines, blowers and similar applications. They give excellent protection against damage and overheating resulting from phase-loss operation.

#### ■ Ordering information

Specify the following:

- Ordering code  
2E type motor starter and phase sequence relay QE-20N.
- Overload relay setting range code
- Operating coil voltage code

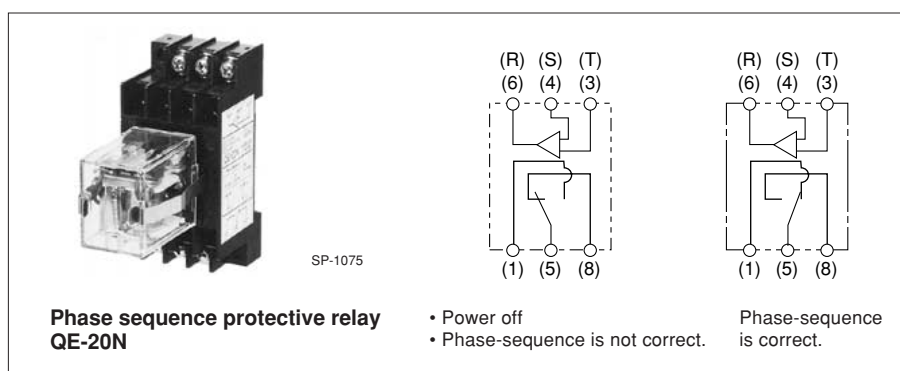
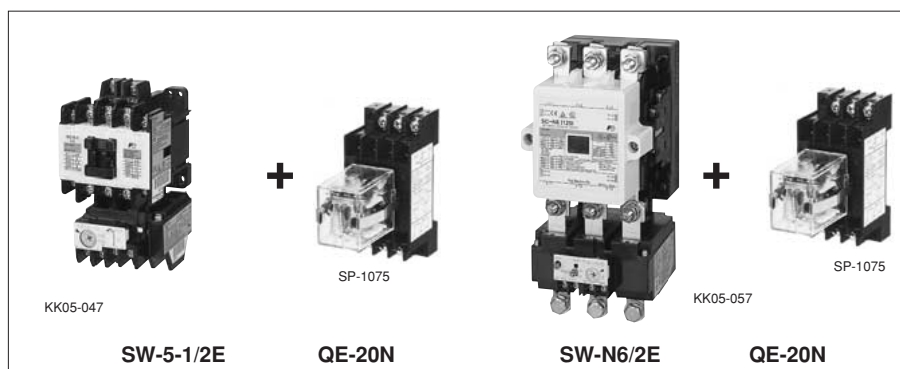

#### ■ Types and ratings

Max. motor capacity (kW)		Operational current (A)		Auxiliary contact	Starter with 2E type thermal overload relay		Phase-sequence protective relay	
200V	380V	200V	380V	Standard	Type	Ordering code	Type	Ordering code
240V	440V	240V	440V					
2.5	4	11	9	1NO *1	SW-03/2E	SC11AAE-■10T□	200-220V:	
3.5	5.5	13	12	1NO *1	SW-0/2E	SC13AAE-■10T□	QE-20N	TQ1CPN
3.5	5.5	13	12	1NO + 1NC *2	SW-05/2E	SC14AAE-■11T□		
4.5	7.5	18	16	1NO *1	SW-4-0/2E	SC18AAE-■10T□		
5.5	11	22	22	1NO *1	SW-4-1/2E	SC19AAE-■10T□	380-415V:	
5.5	11	22	22	1NO + 1NC *3	SW-5-1/2E	SC20AAE-■11T□	QE-40N	TQ2CPN
5.5	11	22	22	2NO + 2NC	SW-5-1/2E	SC20AAE-■22T□		
7.5	15	32	32	2NO + 2NC *4	SW-N1/2E	SC25BAAE-■22T□		
11	18.5	40	40	2NO + 2NC *4	SW-N2/2E	SC35BAAE-■22T□		
15	22	50	50	2NO + 2NC *4	SW-N2S/2E	SC50BAAE-■22T□		
18.5	30	65	65	2NO + 2NC *4	SW-N3/2E	SC65BAAE-■22T□		
22	40	80	80	2NO + 2NC *4	SW-N4/2E	SC80BAAE-■22T□		
30	55	105	105	2NO + 2NC *4	SW-N5/2E	SC93BAAE-■22T□		
37	60	125	125	2NO + 2NC *4	SW-N6/2E	SC1CBAAE-■22T□		
45	75	150	150	2NO + 2NC *4	SW-N7/2E	SC1FBAAE-■22T□		
55	90	180	180	2NO + 2NC *4	SW-N8/2E	SC1JBAAE-■22T□		
65	110	220	220	2NO + 2NC *4	SW-N10/2E	SC2CBAAE-■22T□		
90	160	300	300	2NO + 2NC *4	SW-N11/2E	SC3ABAAE-■22T□		
120	220	400	400	2NO + 2NC *4	SW-N12/2E	SC4ABAAE-■22T□		
180	315	600	600	2NO + 2NC *4	SW-N14/2E	SC6ABAAE-■22T□		

Notes: Enter the coil voltage code in the ■ mark.

Enter the thermal overload relay ampere setting range code in the □ mark.

\*1 Auxiliary contact 1NC is available on request.

\*2 Auxiliary contact 2NO or 2NC is available on request.

\*3 Auxiliary contact 2NO or 2NC is available on request.

\*4 Auxiliary contact 4NO+4NC is available on request for frame sizes N1 and above.

#### ■ Performance data:

Same as standard types.

See page 01/30.

#### ■ Ratings of coil and auxiliary contacts:

See pages 01/28, 30 and 31.

#### ■ TK type thermal overload relays:

See page 01/109.

#### ■ Thermal overload relays with phase-loss and phase-sequence protective relays

Motor starters with 3E relay are fitted with both TK type thermal overload and QE-20N type phase-sequence protective relays.

If the phase rotation of the power supply is not correct the relay will not permit the starter to be switched ON.

These starters provide motors with accurate and consistent protection under overcurrent, phase-loss and reverse-phase conditions.

■ **Method of operation**

The FUJI phase-sequence relay contacts 1–5 will close if the phase rotation of the power source is correct. In case the rotation is incorrect the contacts 1–5 will remain open and the magnetic coil A1–A2 will not be energized.

■ **Dimensions, mm**

● **Starter with phase-loss protection SW-03/2E to 14N/2E (Open)**  
Same as standard types.  
See pages 01/37 to 01/40.

■ **Wiring diagrams (example)**

● **QE-20N, 20NL 200–220V**

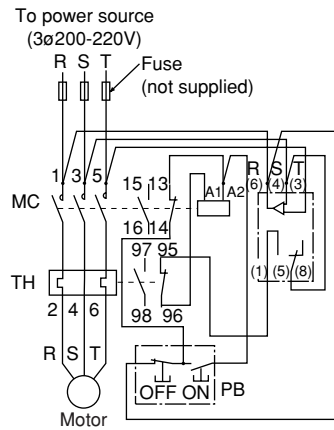

● **QE-40N 380–415V**

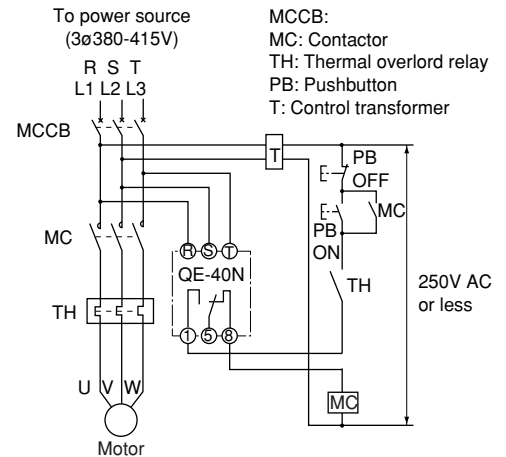

● **Phase-sequence protective relay QE-20N, 20NL**

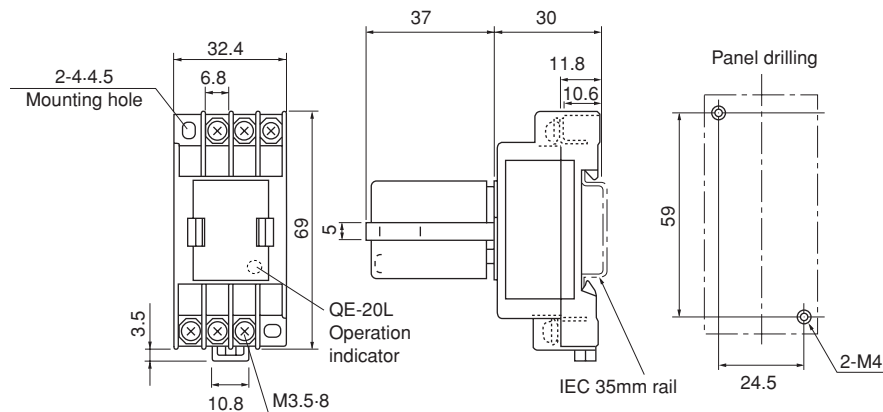

**QE-40N**

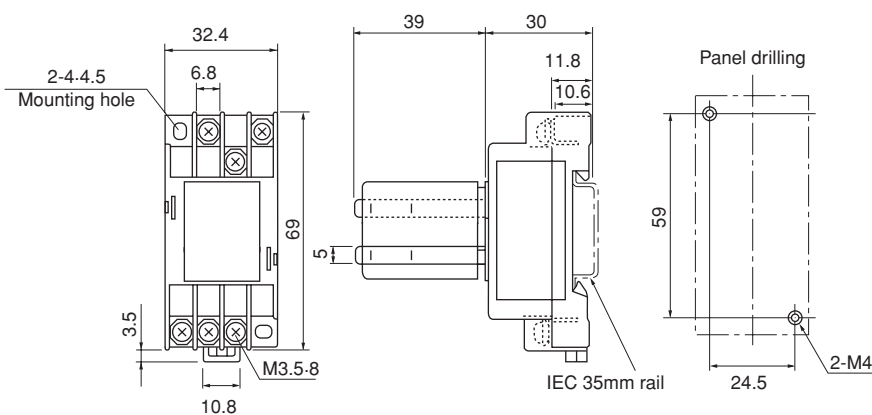

Dimensions for reference only. Confirm before construction begins.

# Magnetic Motor Starters

## SW series

### Enclosed with pushbuttons

#### Motor starters with on-off/reset pushbuttons

Up to 110kW 440 Volts

#### ■ Description

It is provided with on-off push-buttons. Its small size makes little demand on space. The enclosure is a general purpose type and is made of pressed steel sheet. (Plastic enclosure for SW-03P to SW-5-1P)  
Compact, space-saving and easily mounted FUJI integral motor starters are highly reliable and efficient products to satisfy your application requirements. They are used with single and 3-phase squirrel-cage induction motors. Essentially consisting of a magnetic contactor and a thermal overload relay these units provide complete motor overload protection with the convenience of an outside reset button mounted on the front of the starter box.

#### ● Contactors

FUJI integral motor starters use the SC series of contactors. All starters incorporate the usual FUJI features. These include free-floating magnetic mechanisms, bounce damping devices, long-life low-maintenance silver alloy contacts and rapid heat-dispersing arc-quenchers. Starter exceed IEC specifications as far as service life is concerned.

Choice of FUJI equipment will ensure you reduced maintenance, inspection and labor costs and uninterrupted dependable service. Available motor capacities are from 4kW to 110kW at 380 Volts.

#### ● Thermal overload relays

Highly efficient heater elements and ambient temperature compensators give motors added protection and more uniform performance. They are fitted with 3-pole heater elements, and resetting is carried out manually with the reset button.

#### ■ Coil ratings:

See page 01/30.  
Same as standard type starters.



SW-0P/3H

#### ■ Performance data:

- Operating cycle: 1,200 cycles per hours
- Life expectancy (operations)
  - Mechanical: 250,000
  - Electrical: 250,000

#### ■ Thermal overload relay:

See page 01/98.  
Same as standard type starters.

#### ■ Ordering information

Specify the following:

1. Ordering code
2. Overload relay setting range code
3. Operating coil voltage code

#### ■ Ratings

Max. motor capacity (kW) Single-phase 110V	3-phase		Auxiliary contact Standard	With on-off/reset pushbutton		With on-off pushbutton		Combined thermal overload relay
	200V	380V		Type	Ordering code	Type	Ordering code	
	240V	440V						
0.4	2.5	4	1NO	SW-03P/3H	SC11PAN-■10T□D	—	—	TR-0N/3
0.5	3.5	5.5	1NO	SW-0P/3H	SC13PAN-■10T□D	—	—	TR-0N/3
0.5	3.5	5.5	1NO+1NC	SW-05P/3H	SC14PAN-■11T□D	—	—	TR-0N/3
0.6	4.5	7.5	1NO	SW-4-0P/3H	SC18PAN-■10T□D	—	—	TR-5-1N/3
0.8	5.5	11	1NO	SW-4-1P/3H	SC20PAN-■10T□D	—	—	TR-5-1N/3
0.8	5.5	11	1NO+1NC	SW-5-1P/3H	SC20PAN-■11T□D	—	—	TR-5-1N/3
1.2	7.5	15	2NO+2NC	SW-N1PB/3H	SC25BSAN-■22T□D	SW-N1P/3H	SC25BPAN-■22T□D	TR-N2/3
1.7	11	18.5	2NO+2NC	SW-N2PB/3H	SC35BSAN-■22T□D	SW-N2P/3H	SC35BPAN-■22T□D	TR-N2/3
—	15	22	2NO+2NC	SW-N2SPB/3H	SC50BSAN-■22T□D	SW-N2SP/3H	SC50BPAN-■22T□D	TR-N3/3
—	18.5	30	2NO+2NC	SW-N3PB/3H	SC65BSAN-■22T□D	SW-N3P/3H	SC65BPAN-■22T□D	TR-N3/3
—	22	40	2NO+2NC	SW-N4PB/3H	SC80BSAN-■22T□D	—	—	TR-N5/3
—	30	55	2NO+2NC	SW-N5PB/3H	SC93BSAN-■22T□D	—	—	TR-N5/3
—	37	60	2NO+2NC	SW-N6PB/3H	SC1CBSAN-■22T□D	—	—	TR-N6/3
—	55	90	2NO+2NC	SW-N8PB/3H	SC1JBSAN-■22T□D	—	—	TR-N8/3
—	65	110	2NO+2NC	SW-N10PB/3H	SC2CBSAN-■22T□D	—	—	TR-N10/3

Notes: 2-element is available on request.

Enter the coil voltage code in the ■ mark.

Enter the thermal overload relay ampere setting range code in the □ mark.

#### ■ Wiring diagrams

SW-03P/3H, 0P/3H  
SW-4-0P/3H, 4-1P/3H

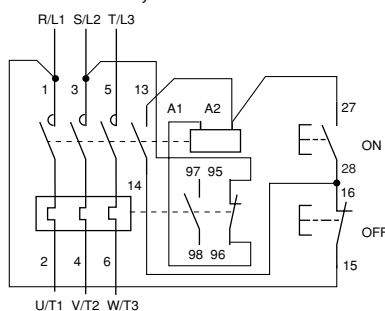

SW-05P/3H, 5-1P/3H

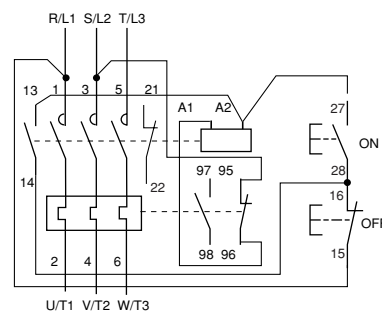

SW-N1PB/3H to N10PB/3H  
SW-N1P/3H to N3P/3H

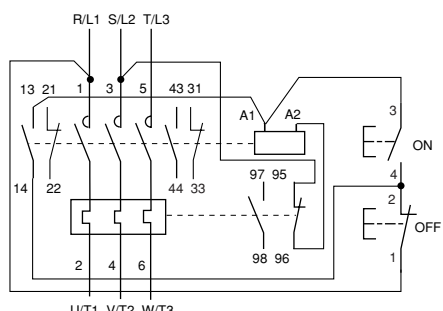

■ Dimensions, mm  
 SW-03P to SW-5-1P

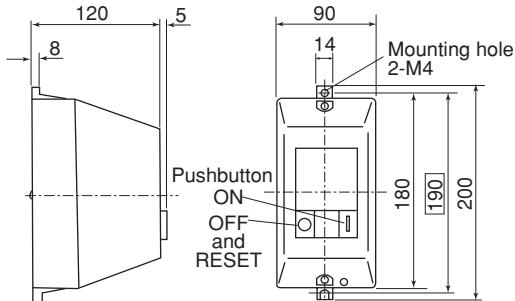

Type	Mass (kg)
SW-03P/3H	0.82
SW-0P/3H	0.82
SW-05P/3H	0.84
SW-4-0P/3H	0.86
SW-4-1P/3H	0.86
SW-5-1P/3H	0.89

Plastic enclosure

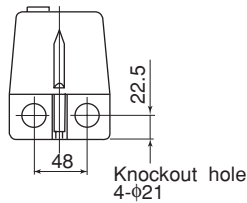

SW-N1PB to SW-N5PB  
 SW-N1P to SW-N3P

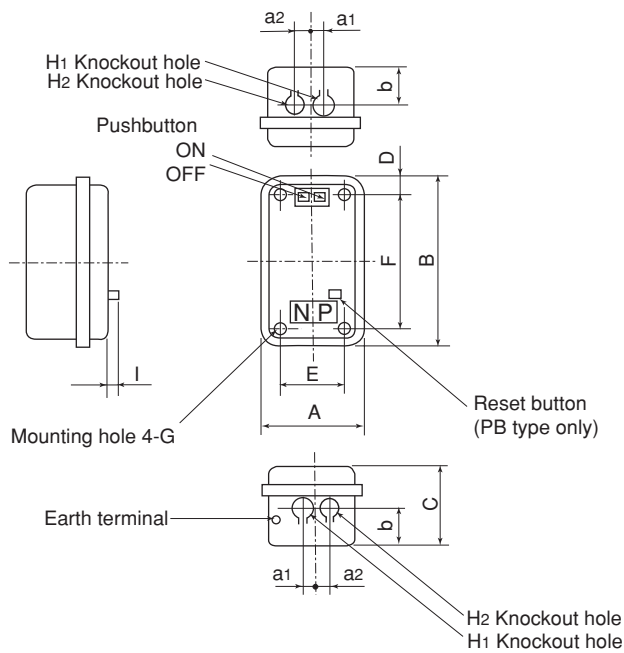

SW-N6PB to SW-N10PB

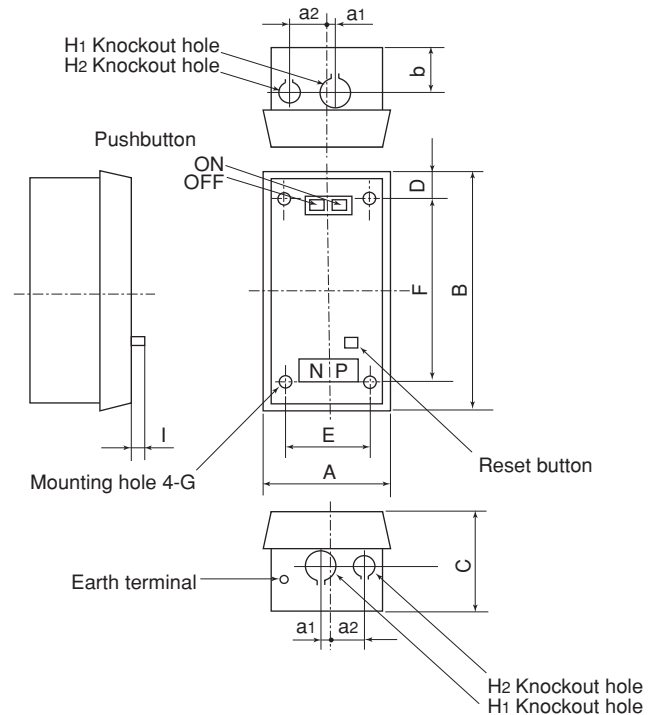

Type		A	B	C	D	E	F	G	H <sub>1</sub>	H <sub>2</sub>	I	a <sub>1</sub>	a <sub>2</sub>	b	Mass (kg)	
															PB type	P type
SW-N1PB/3H	N1P/3H	175	320	145	35	110	250	M6	φ35	φ28	12	15	35	70	2.6	2.5
SW-N2PB/3H	N2P/3H	175	320	145	35	110	250	M6	φ35	φ28	12	15	35	70	2.6	2.5
SW-N2SPB/3H	N2SP/3H	175	320	145	35	110	250	M6	φ35	φ28	12	15	35	70	3.2	3.1
SW-N3PB/3H	N3P/3H	175	320	145	35	110	250	M6	φ35	φ28	12	15	35	70	3.2	3.1
SW-N4PB/3H		200	400	160	37	125	325	M8	φ43	φ28	12	20	40	80	4.6	—
SW-N5PB/3H		200	400	160	37	125	325	M8	φ43	φ28	12	20	40	80	5.0	—
SW-N6PB/3H		225	450	180	50	150	350	M8	φ52	φ28	12	10	70	80	8.6	—
SW-N8PB/3H		335	670	225	85	200	500	M10	φ78	φ28	11	—	100	95	18.2	—
SW-N10PB/3H		335	670	225	85	200	500	M10	φ78	φ28	11	—	100	95	19.3	—

Mass: with 3-thermal element

# Magnetic Motor Starters

## SW series

### Dust-tight/light-corrosion resistance

#### Dust-tight/light-corrosion resistance starters

##### ■ Description

When selecting a motor starter the operating conditions must be carefully considered. Attention must be given to such problems as dust, chemically aggressive atmosphere, water, oil and hazardous materials.

We can supply enclosures that meet the special needs of such industries as the cement and textile industries, where dust and lint can be expected, and the fertilizer, synthetic fiber, oil refining and electrochemical and metal-plating industries where corrosive gases and materials can affect the performance of electrical equipment.

A pressed metal enclosure designed for use in locations where dust, lint, fibers and similar airborne materials are present. The hingeless-type cover is provided with a corrosion-resistant rubber gasket and it is secured by screws. Knockout holes are situated at the top and bottom of the enclosure to accept conduit hubs or glands.

This type is for indoor use.

The outside surface of the enclosure is treated with a special anti-corrosion coating. This type of case is

recommended for cement and fertilizer plants and similar dusty locations. It is also suitable for oil refineries, breweries and metal-plating workshops and coastal areas where aggressive chemical conditions can be expected. This type of enclosure is not suitable for hazardous gas or hazardous dust locations.

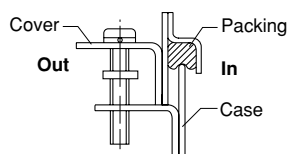

##### ■ Ordering information

Specify the following:

1. Ordering code
2. Overload relay setting range code
3. Operating coil voltage code
4. Method of wiring works and size of conduit pipe
5. Type and density of gas



■ **Types and ratings:** See page 01/33. Same as standard enclosed type.

■ **Performance data:** Same as standard type. See page 01/30.

■ **Ratings of coil and auxiliary contact:**

See pages 01/28, 30 and 31.

■ **Thermal overload relay:** See page 01/97.

##### ■ Application for special atmosphere

Description	Standard type	Dust-tight/light corrosion res. (lg)
Dust-tight	—	○
Moisture-proof	○	○
Drip-proof	—	—
Splashing-proof	—	○
Rain-proof	—	—
Corrosion-resistant		
Light	○	○
Medium	—	○
Hazardous locations	—	—
Gas-tight	—	—

Note: ○ : Available  
— : Not available

##### ■ Dimensions, mm

#### SW-03LG to SW-5-1LG

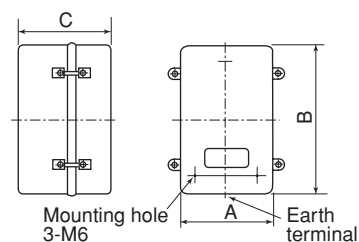

#### SW-N6LG to N10LG

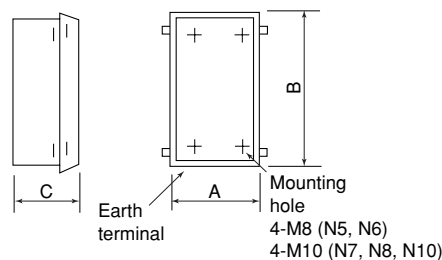

#### SW-N1LG to SW-N5LG

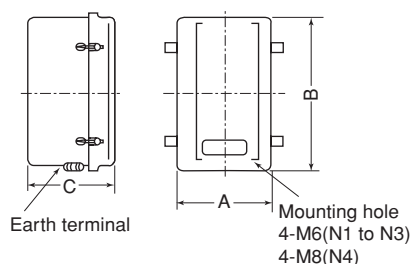

Dimensions for reference only. Confirm before construction begins.

Type	Ordering code	Aux. contact	A	B	C	Mass (kg)
SW-03LG/3H	SC11LAN-■10T□D	1NO	120	195	117	1.4
SW-0LG/3H	SC13LAN-■10T□D	1NO	120	195	117	1.4
SW-05LG/3H	SC14LAN-■11T□D	1NO + 1NC	120	195	117	1.4
SW-4-0LG/3H	SC18LAN-■10T□D	1NO	120	195	117	1.5
SW-4-1LG/3H	SC19LAN-■10T□D	1NO	120	195	117	1.5
SW-5-1LG/3H	SC20LAN-■11T□D	1NO + 1NC	120	195	117	1.5
SW-N1LG/3H	SC25LAN-■22T□D	2NO + 2NC	145	246	135	2.0
SW-N2LG/3H	SC35LAN-■22T□D	2NO + 2NC	145	246	135	2.0
SW-N2SLG/3H	SC50LAN-■22T□D	2NO + 2NC	175	320	145	3.1
SW-N3LG/3H	SC65LAN-■22T□D	2NO + 2NC	175	320	145	3.1
SW-N4LG/3H	SC80LAN-■22T□D	2NO + 2NC	200	400	160	4.5
SW-N5LG/3H	SC93LAN-■22T□D	2NO + 2NC	200	400	160	4.5
SW-N6LG/3H	SC1CLAN-■22T□D	2NO + 2NC	225	450	180	8.5
SW-N7LG/3H	SC1FLAN-■22T□D	2NO + 2NC	280	588	210	12.3
SW-N8LG/3H	SC1JLAN-■22T□D	2NO + 2NC	335	698	225	18.1
SW-N10LG/3H	SC2CLAN-■22T□D	2NO + 2NC	335	698	225	18.8

■: Coil voltage code    □: Thermal overload relay ampere setting range code

**Resistance load magnetic contactors**

**Description**

These single pole contactors are for exclusively resistive load use. They are provided with large and sturdy parallel plate terminals attached to the 3-pole standard contactors to make them suitable for large current ratings. Typical applications are for industrial heating controls, PVA processing, solution vats, electric resistance furnaces, heat treatment facilities, drying kilns, farming, marine farming, lighting and similar purposes.

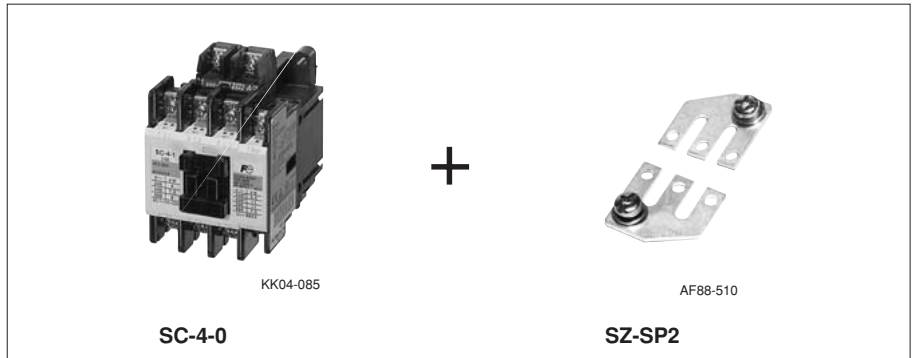

**Ordering information**

Specify the following:

1. Ordering code
2. Operating coil voltage code
3. State clearly "with parallel plate terminals for attaching to contactor".
4. Application and rated load current

**Types and ratings**

Operational current (A) 110V/220V	Auxiliary contact		Making and breaking current	Operating cycles per hour	Life expectancy (operations)		Contactor Type		3-pole parallel terminal plate	
	NO	NC			Electrical	Mechanical	Type	Ordering code	Type	Ordering code
25	1	—	1.5 × Ie	150	500,000	10 millions	SC-03	SC11AA-■10	SZ-SP1	SZ1SP1
30	1	—	1.5 × Ie	150	500,000	10 millions	SC-0	SC13AA-■10	SZ-SP1	SZ1SP1
30	1	1	1.5 × Ie	150	500,000	10 millions	SC-05	SC14AA-■11	SZ-SP1	SZ1SP1
40	1	—	1.5 × Ie	150	500,000	10 millions	SC-4-0	SC18AA-■10	SZ-SP2	SZ1SP2
50	1	—	1.5 × Ie	150	500,000	10 millions	SC-4-1	SC19AA-■10	SZ-SP2	SZ1SP2
50	1	1	1.5 × Ie	150	500,000	10 millions	SC-5-1	SC20AA-■11	SZ-SP2	SZ1SP2
50	2	2	1.5 × Ie	150	500,000	10 millions	SC-5-1	SC20AA-■22	SZ-SP2	SZ1SP2
100	2	2	1.5 × Ie	150	500,000	5 millions	SC-N1	SC25BAA-■22	SZ-SP3	SZ2SP3
125	2	2	1.5 × Ie	150	500,000	5 millions	SC-N2	SC35BAA-■22	SZ-SP3	SZ2SP3
200	2	2	1.5 × Ie	150	250,000	5 millions	SC-N2S	SC50BAA-■22	SZ-SP4	SZ2SP4
250	2	2	1.5 × Ie	150	250,000	5 millions	SC-N3	SC65BAA-■22	SZ-SP4	SZ2SP4
315	2	2	1.5 × Ie	150	250,000	5 millions	SC-N4	SC80BAA-■22	SZ-SP5	SZ2SP5
400	2	2	1.5 × Ie	150	250,000	5 millions	SC-N5	SC93BAA-■22	SZ-SP5	SZ2SP5
400	2	2	1.5 × Ie	150	250,000	5 millions	SC-N6	SC1CBAA-■22	SZ-SP6	SZ2SP6
500	2	2	1.5 × Ie	150	250,000	5 millions	SC-N7	SC1FBAA-■22	SZ-SP7	SZ2SP7
630	2	2	1.5 × Ie	150	250,000	5 millions	SC-N8	SC1JBAA-■22	SZ-SP8	SZ2SP8
710	2	2	1.5 × Ie	150	250,000	5 millions	SC-N10	SC2ABAA-■22	SZ-SP8	SZ2SP8
900	2	2	1.5 × Ie	150	250,000	5 millions	SC-N11	SC3ABAA-■22	SZ-SP9	SZ2SP9
1000	2	2	1.5 × Ie	150	250,000	5 millions	SC-N12	SC4ABAA-■22	SZ-SP9	SZ2SP9
1600	2	2	1.5 × Ie	150	250,000	5 millions	SC-N14	SC6ABAA-■22	SZ-SP10	SZ2SP10
2100	2	2	1.5 × Ie	150	100,000	2,500,000	SC-N16	SC8ABAA-■22	SZ-SP11	SZ2SP11

Notes: 1. ■: Coil voltage code, see page 01/27  
 2. Ie: Rated operational current. Conforming to Class AC-1, IEC60947-4-1.

**Dimensions, mm**

**SC-03 + SZ-SP1 to SC-5-1 + SZ-SP2**

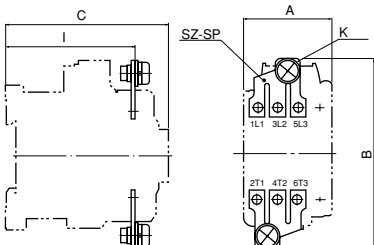

**SC-N1+SZ-SP3 to SC-N16+SZ-SP11**

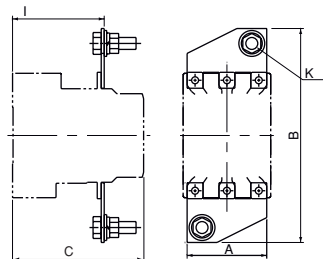

Type	A	B	C	I	K	Mass (g) *
SC-03+SZ-SP1	43	90	80	63	M6	25
SC-0+SZ-SP1	43	90	80	63	M6	25
SC-05+SZ-SP1	53	90	80	63	M6	25
SC-4-0+SZ-SP2	53	100	81	63	M6	35
SC-4-1+SZ-SP2	53	100	81	63	M6	35
SC-5-1+SZ-SP2	64	100	81	63	M6	35
	64	100	109	63	M6	35
SC-N1, N2+SZ-SP3	74	132	96	64	M8	110
SC-N2S, N3+SZ-SP4	88	174	111	75.5	M10	200
SC-N4+SZ-SP4	88	215	117	77	M12	320

Type	A	B	C	I	K	Mass (g) *
SC-N5+SZ-SP4	88	215	132	92	M12	320
SC-N6+SZ-SP6	100	300	138	98	M12×2	760
SC-N7+SZ-SP7	115	312	140	98	M12×2	800
SC-N8, N10+SZ-SP8	138	371	174	120	M12×2	1300
SC-N11, N12+SZ-SP9	153	420	195	135	M12×4	3000
SC-N14+SZ-SP10	290	525	328	246	M12×4	4400
SC-N16+SZ-SP11	290	525	328	246	M12×4	5900

\*Mass: 3-pole parallel terminal plate only

# Magnetic Contactors

## SC series

### With single button auxiliary contact

#### Magnetic contactors with single button auxiliary contact

##### ■ Description

The SC-03H to N12H contactors are improved versions of the standard SC-03 to SC-N12 contactors. The improvement consists of changing the auxiliary contact from a bifurcated to a single button type contact. This change increases the auxiliary contact rating. The specifications, including the main contact rating and the expected electrical service life, are similar to that of the SC-03 to N12 types. The options for the SC series, such as the coil surge suppressor and mechanical interlock can also be used.

##### ■ Type number nomenclature

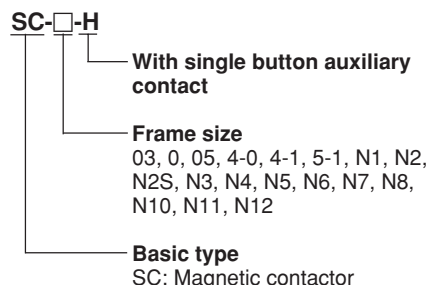

##### ■ Performance data

Same as standard types

##### ■ Ordering information

Specify the following:

1. Ordering code
2. Operating coil voltage code
3. Auxiliary contact arrangement code.



##### ■ Coil voltage

Same as standard type, See page 01/30

#### ■ Ratings (Conforming to AC-3, IEC 60947-4-1)

Type	Ordering code	Max. motor capacity (kW)				Rated operational current (A)				Rated thermal current (A)	Auxiliary contact
		3-phase				3-phase					
		200V	380V	500V	600V	200V	380V	500V	600V		Standard
		240V	440V	550V	660V	240V	440V	550V	660V		
SC-03H	SC11AH-■10	2.5	4	4	4	11	9	7	5	20	1NO
SC-0H	SC13AH-■10	3.5	5.5	5.5	5.5	13	12	9	7	20	1NO
SC-05H	SC14AH-■11	3.5	5.5	5.5	5.5	13	12	9	7	20	1NO+1NC
SC-4-0H	SC18AH-■10	4.5	7.5	7.5	7.5	18	16	13	9	25	1NO
SC-4-1H	SC19AH-■10	5.5	11	11	7.5	22	22	17	9	32	1NO
SC-5-1H	SC20AH-■11	5.5	11	11	7.5	22	22	17	9	32	1NO+1NC
SC-5-1H	SC20AH-■22	5.5	11	11	7.5	22	22	17	9	32	2NO+2NC *
SC-N1H	SC25BAH-■11	7.5	15	15	11	32	32	24	15	50	2NO+2NC
SC-N2H	SC35BAH-■11	11	18.5	18.5	15	40	40	29	19	60	2NO+2NC
SC-N2SH	SC50BAH-■11	15	22	25	22	50	50	38	26	80	2NO+2NC
SC-N3H	SC65BAH-■11	18.5	30	37	30	65	65	60	38	100	2NO+2NC
SC-N4H	SC80BAH-■11	22	40	37	37	80	80	60	44	135	2NO+2NC
SC-N5H	SC93BAH-■11	30	55	55	55	105	105	85	64	150	2NO+2NC
SC-N6H	SC1CBAH-■11	37	60	60	60	125	125	90	72	150	2NO+2NC
SC-N7H	SC1FBAH-■11	45	75	75	90	150	150	120	103	200	2NO+2NC
SC-N8H	SC1JBAH-■11	55	90	130	132	180	180	180	150	260	2NO+2NC
SC-N10H	SC2CBAH-■11	65	110	132	132	220	220	200	150	260	2NO+2NC
SC-N11H	SC3ABAH-■11	90	160	160	200	300	300	230	230	350	2NO+2NC
SC-N12H	SC4ABAH-■22	120	220	250	300	400	400	360	360	360	2NO+2NC

Notes: Enter the coil voltage code in the ■ mark

\* With auxiliary contact block SZ-A11 (1NO+1NC)

#### ■ Auxiliary contact ratings (Conforming to IEC 60947-5-1)

Type	Continuous current (A)	Make/break current (AC, A)	Rated operational current (A)			DC Voltage (V)	DC-13 (Ind. load)	DC-12 (Res. load)
			AC Voltage (V)	AC-15 (Ind. load)	AC-12 (Res. load)			
SC-03H to SC5-1H	10	60	100–120	6	10	24	5	10
			200–240			48	1.5	5
			380–440	4	10	110	0.7	4
SC-N1H to SC-N12H	10	60	100–120	6	10	24	10	10
			200–240			48	3	5
			380–440	4	10	110	1.5	2.5
		25	500–600	2.5	10	220	0.5	1

**Contactors and starters with quick connection terminals**

■ **Feature**

- Easy wiring  
Wiring time is at least 50% shorter than previous type.
- Safety  
The finger protection feature protects the charging current part during maintenance and check (complying with EN60947-4-1, and IEC60947-4-1)
- International use  
The product and terminal structure comply with international safety standards.  
It complies with VGB4, DIN57106, VDE0106, and VDE Teil 100 which are recommendation for preventing the exposure of charging current part.

**Quick connection terminal**

- When one crimp terminal is used

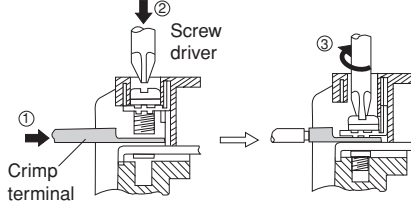

- When two crimp terminals are used

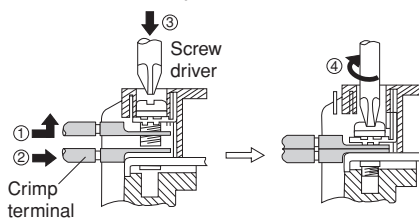

■ **Types and rating**

Max. motor capacity (kW) 3-phase AC-3 200V 380V 240V 440V	Rated operational current (A)				Rated thermal current (A)	Auxiliary contact arrangement	Contactor Type	Starter 3-element Type
	3-phase motor AC-3 200V 380V 240V 440V	Resistive load AC-1 200V 380V 240V 440V	200V	380V				
2.5 4	11 9	20 20	20	20	1NO 1NC	SC-03Y10 SC-03Y01	SW-03Y/3H10 SW-03Y/3H01	
3.5 5.5	13 12	20 20	20	20	1NO 1NC	SC-0Y10 SC-0Y01	SW-0Y/3H10 SW-0Y/3H01	
3.5 5.5	13 12	20 20	20	20	2NO 1NO,1NC 2NC	SC-05Y20 SC-05Y11 SC-05Y02	SW-05Y/3H20 SW-05Y/3H11 SW-05Y/3H02	
5.5 11	22 22	32 32	32	32	2NO 1NO,1NC 2NC	SC-5-1Y20 SC-5-1Y11 SC-5-1Y02	SW-5-1Y/3H20 SW-5-1Y/3H11 SW-5-1Y/3H02	

■ **Ordering information**

- Specify the following:
1. Type number
  2. Coil voltage (Contactor only)
  3. Main circuit voltage (Starter only)
  4. Thermal overload setting range code (Starter only)
- See page 01/27.

■ **Dimensions and panel drilling**

Same as the standard types

■ **Mass**

Same as the standard types

■ **Optional unit**

**Auxilliary contact blocks with quick connection terminals**

Mounting	Thermal current (A)	Contact arrangement	Type
Front mounting	10	4NO 3NO+1NC 2NO+2NC	SZ-A40Y SZ-A31Y SZ-A22Y
		2NO 1NO+1NC 2NO	SZ-A20Y SZ-A11Y SZ-A02Y

● **Dimensions and contact arrangement diagrams**

Same as the standard type auxiliary contact blocks.  
See page 01/77.

