

**Photoelectric switches with built-in amplifier
PH1C**

■ **Features**

- Highly compact with dimensions of 10.8 x 31 x 20mm
- Energy-saving design
- Covers a wide range of detection with distances of 10m (transmission type), 3 or 4m (retroreflective type), or 1m (diffuse reflection type)
- Retroreflective type equipped with mirror surface rejection function
- High-speed response time of 1ms
- Light-ON/Dark-ON selectable with operation mode switch
- Equipped with various protective functions
- High degree of protection of IP67 (IEC) enables use even in environments where exposure to water is possible.
- Improved alignment ($\pm 2.5^\circ$) of optical and mechanical axes simplifies adjustment (transmission type, retroreflective type)
- Environment-friendly lead-free solder used
- Meets CE Mark requirements.

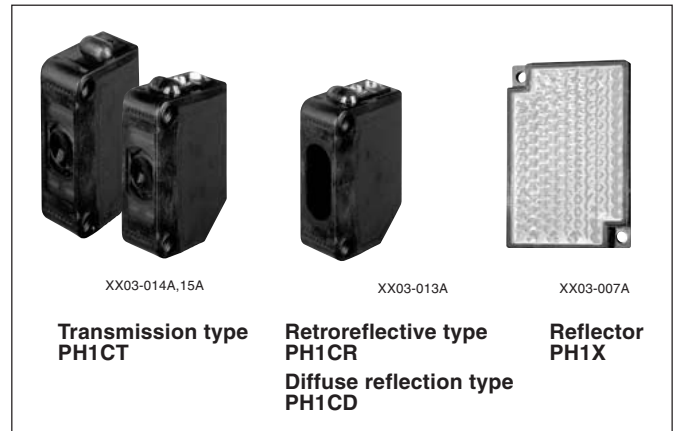

■ **Types**

Detecting method	Detecting distance	Light emitting element	Output	Output operation mode	Type	Supplied item	
							Cable length
Transmission type 	10m	Red LED	NPN transistor, open collector output	Dark-ON / Light-ON selectable	PH1CT-M1DC	Light source and receiver	2m
					PH1CT-M1DCSN		5m
					PH1CT-M1DCST		10m
					PH1CT-M1DCR	Receiver	2m
					PH1CT-M1DCRLN		5m
					PH1CT-M1DCT	Light source	2m
PH1CT-M1DCTLN	5m						
Retroreflective type (with mirror surface rejection) 	0.1 to 3m (using PH1X-R1) 0.1 to 4m (using PH1X-R1S)	Red LED			PH1CR-3MDC	Light source/receiver	2m
					PH1CR-3MDCLN		5m
Diffuse reflection type 	1m	Infrared LED			PH1CD-1MDC	Light source/receiver	2m
					PH1CD-1MDCLL		3m

Photoelectric Switches

PH1C

■ Ratings and specifications

Detection method	Transmission type	Retroreflective type (with mirror surface rejection)	Diffuse reflection type
Type	PH1CT-M1DC	PH1CR-3MDC	PH1CD-1MDC
Light emitting element	Red LED		Infrared LED
Supply voltage	12 to 24V DC $\pm 10\%$ (ripple $\pm 10\%$ or less)		
Current consumption	Light source: 15mA, Receiver: 20mA	30mA max.	
Detecting distance	10m	0.1 to 3m (using PH1X-R1) 0.1 to 4m (using PH1X-R1S)	1m (white mat paper 30 x 30cm)
Detectable target	Opaque 12mm dia. min.	Opaque 75mm dia. min.	Transparent or opaque
Directional angle	Light source and receiver: 3 to 15° each	Light source/receiver: 2 to 10°, Reflector: 30°	–
Differential	–		Max. 20% of detecting distance
Detecting output	NPN transistor, open collector output Load current: 100mA max. (26.4V DC) Residual voltage: 1V DC max. at load current less than 10mA 2V DC max. at load current of 10 to 100mA		
Output operation mode	Dark-ON / Light-ON selectable		
Response time	1ms max. (operation/reset)		
Indicator	Operation indicator	Orange LED (Light source: power supply indicator)	Orange LED
	Stability level indicator	Green LED (Receiver)	Green LED
Connection	Attached cable (2m, 0.2mm ²)		
Sensitivity adjustment	Dial		
Ambient operating illumination	Incandescent lamp: 3000 lx max. (at receiving surface) Sunlight: 10000 lx max. (at receiving surface)		
Ambient temperature	Operating: -25 to $+55^{\circ}\text{C}$ (no icing), storage: -40 to $+70^{\circ}\text{C}$		
Ambient humidity	Operating: 35 to 85%RH (no condensation), storage: 35 to 95%RH		
Degree of protection	IP67 (IEC)		
Protective function	Reverse polarity (input), short-circuit and reverse polarity (output)	Reverse polarity (input), short-circuit, reverse polarity (output) and mutual interference	
Insulation resistance	20M Ω (500V DC megger)		
Dielectric strength	1,000V AC for 1min		
Vibration	10 to 55Hz, 1.5mm double amplitude or 300m/s ² (2 hours for each X, Y, Z direction)		
Shock	500m/s ² (3 times for each X, Y, Z direction)		
Material	Casing	Polybutylene terephthalate resin (PBT)	
	Lens	Polyarylate resin (PAR)	Methacrylic resin (PMMA)
Mass	Approx. 120g	Approx. 65g	Approx. 65g
Accessory (option)	Mounting bracket (PH1X-P1, PH1X-P2)		

Note : Reflectors PH1X-R1 and R1S (for retroreflective type PH1CR use) are sold separately.

■ Type number nomenclature

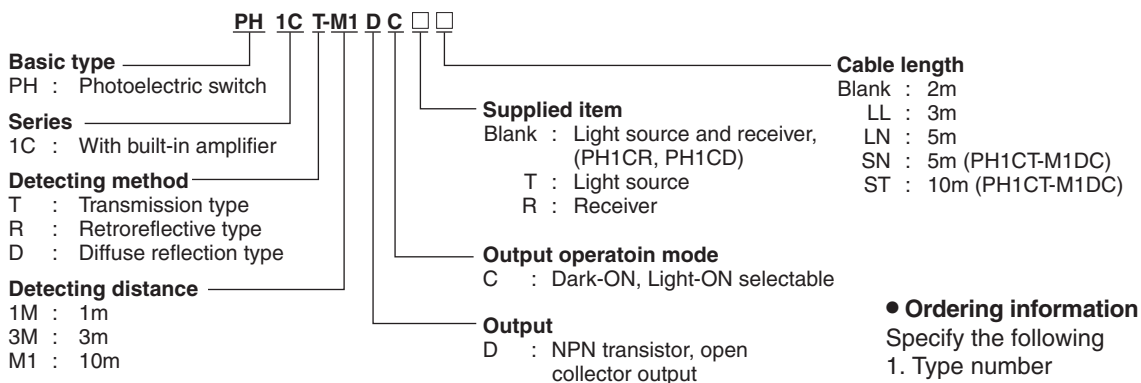

■ Dimensions, mm

● PH1CT-M1DC

Light source

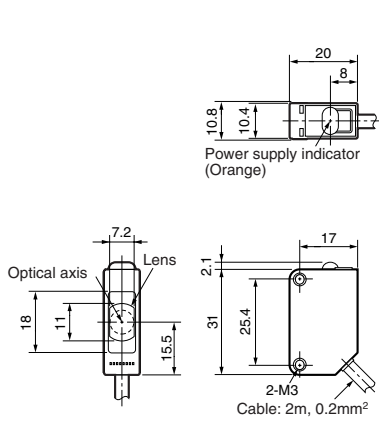

Receiver

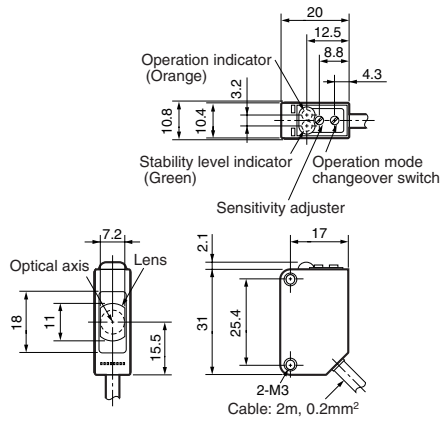

● PH1CR-3MDC, PH1CD-1MDC

Light source/receiver

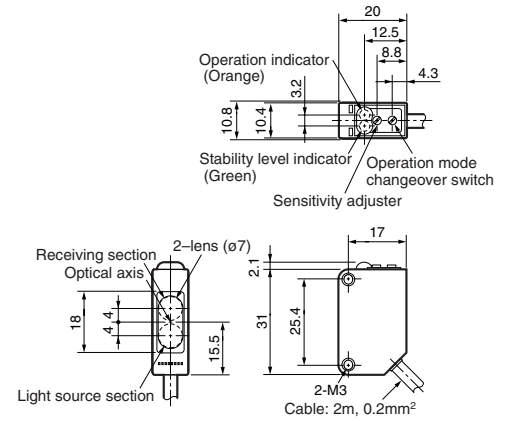

■ Dimensions, mm (sold separately)

● Reflector

PH1X-R1, PH1X-R1S

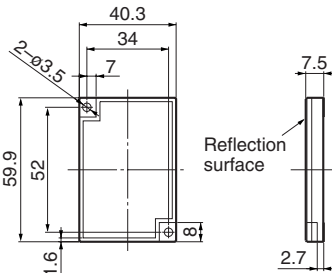

Reflection surface: Methacrylic resin (PMMA)
Reverse side: Acrylonitrile butadiene styrene resin (ABS)

● Mounting bracket

PH1X-P1

Stainless

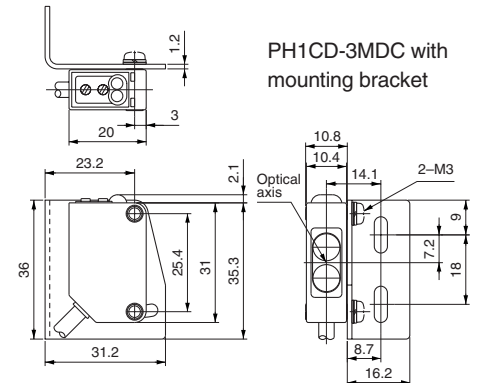
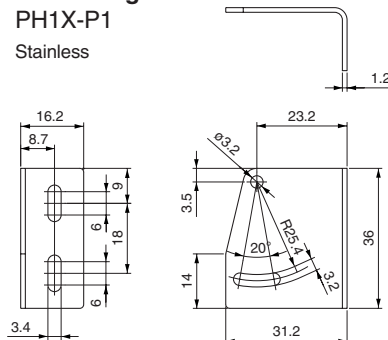

● Slit

PH1X-SP, PH1X-S1, PH1X-S2

Stainless

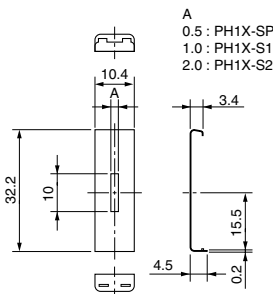

PH1X-P2

Stainless

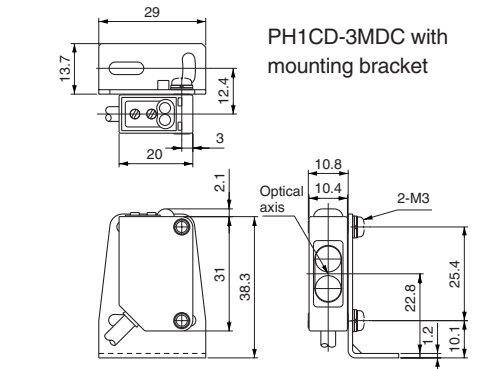
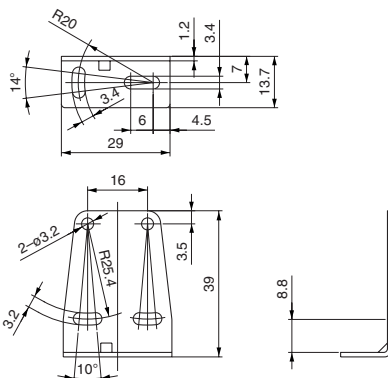

● Detection characteristics using PH1X slit

Photoelectric switch	PH1CT-M1DC		
Slit width (mm)	0.5×10	1×10	2×10
Detecting distance (m)	0.7	1.5	3.5
Minimum detectable target (mm dia.)	0.2	0.5	0.8

Photoelectric Switches PH1C

■ Characteristic curve, typical

● Receiver output-Distance

PH1CT-M1DC

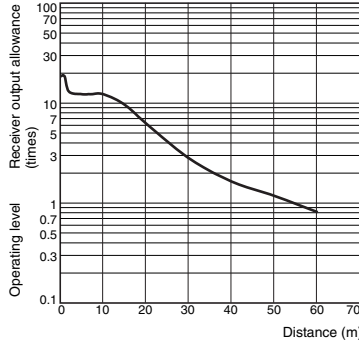

PH1CR-3MDC + Reflector

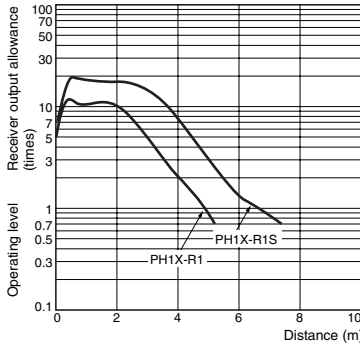

PH1CD-1MDC

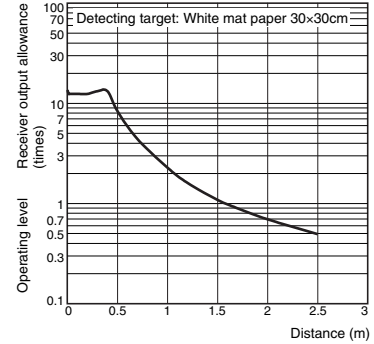

● Setting range of light source and receiver head

PH1CT-M1DC

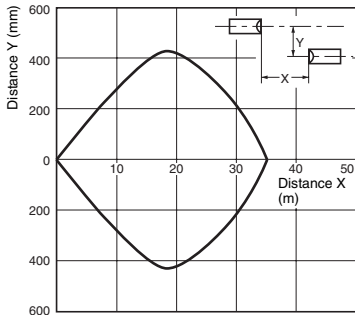

PH1CT-M1DC + Slit

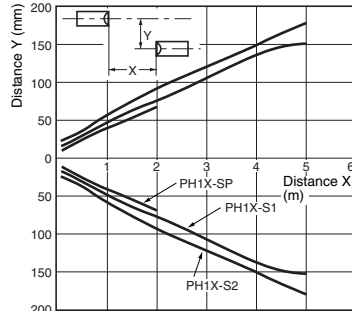

PH1CR-3MDC + Reflector

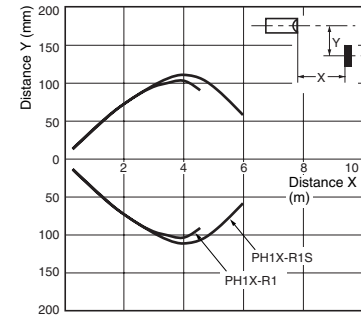

● Size of detecting target - Distance

PH1CD-1MDC

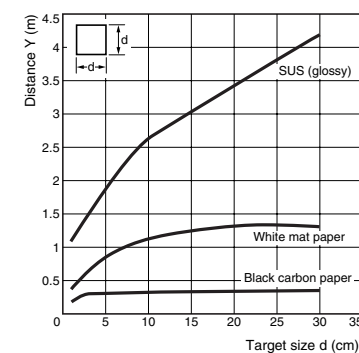

● Operating range

PH1CD-1MDC

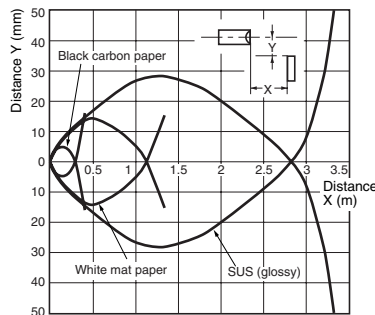

■ Wiring diagrams

PH1CT receiver, PH1CR, PH1CD

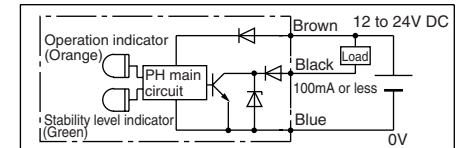

PH1CT light source

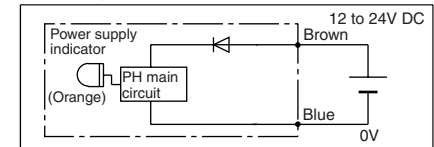

■ Timing diagrams

● "Light-ON" mode (switch: L side)

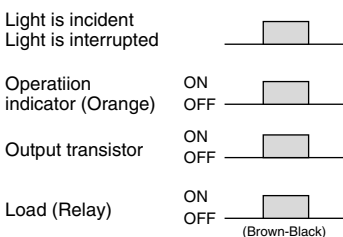

● "Dark-ON" mode (switch: D side)

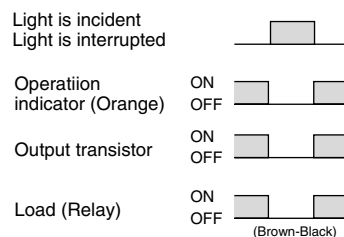

■ Indicator

● Operation indicator (Ope)

Lights when the switch is activated (output transistor ON) irrespective of Light-ON, Dark-ON.

● Stability level indicator (Stab)

Lights when the incident light or shaded light is good enough for stable level.

Status of incident light		Indicator	Stab (green)	Ope (orange)	Allowance
Light-ON	Dark-ON				
Stable incident	Stable shade		ON	ON	Operation level $\times 1.11$
Unstable incident	Unstable shade		OFF	ON	
Unstable shade	Unstable incident		OFF	OFF	Operation level
Stable shade	Stable incident		ON	OFF	Operation level $\times 0.86$

■ Optical axis adjustment

● Transmission type

Swinging the light source and receiver up and down and right and left when no objects exist, set and fix the light source and receiver to the center within the range where the operation indicator (orange) is lit or is turned off (Dark-ON). At the same time make sure that the stability level indicator (green) is lit.

● Retroreflective type

Swinging the unit and reflector up and down and right and left when no objects exist, set and fix the unit and reflector to the center within the range where the operation indicator (orange) is lit or is turned off (Dark-ON). At the same time make sure that the stability level indicator (green) is lit.

■ Sensitivity adjustment

- When carrying a normal detection, set the sensitivity adjuster at the maximum sensitivity value by turning it fully clockwise.
- Sensitivity adjustment is necessary for the following cases.
 - Transmission type: To detect translucent or minute objects
 - Reflection type: To detect objects with inadequate contrast
- Carry out the sensitivity adjustment as follows. (When excessive power is added to the sensitivity adjuster, it might be damaged.)

Step	State of detected object		Operation indicator and sensitivity adjuster		Step
	Transmission type	Reflection type	Light-ON	Dark-ON	
1		Detected object 			By turning the sensitivity adjuster, obtain point A and B at that the status of the operation indicator changes. Unless the status changed, two points at finishing turning the sensitivity adjuster will be point A or B.
2		Background object 			
3					An intermediate position between point A and B will be the optimum position.

Note: ⚙ lit, ● not lit