

■ Design features

Direct-Drive switching mechanism

A vertical link mechanism is used for the switching mechanism to reduce the torque of the moving contact arm, serve as a countermeasure against increased contact opening distance, and improve contact opening speed.

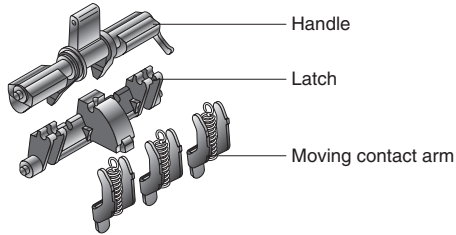

Contact opening distance/Moving contact arm torque

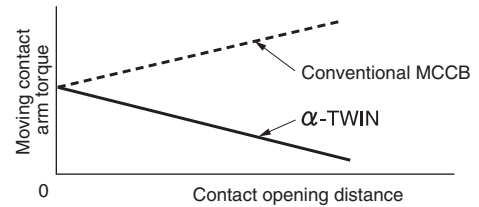

High-performance arc quenching chamber

The combination of the simple Flat Turn contact arm, blowout magnet, and arc-quenching chamber provided a unique current-limiting effect.

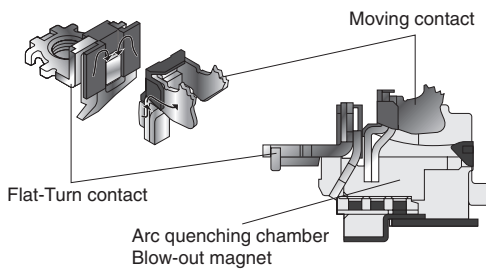

Structure of the arc-quenching chamber

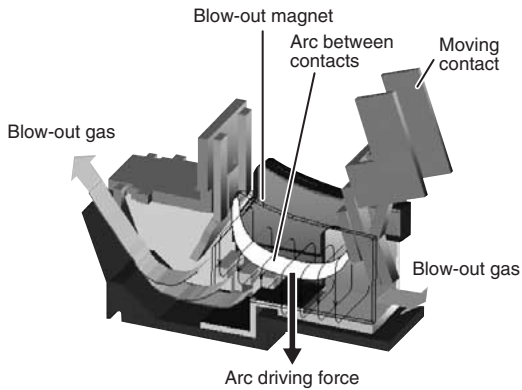

Comparison of arc voltages resulting from short-circuit current

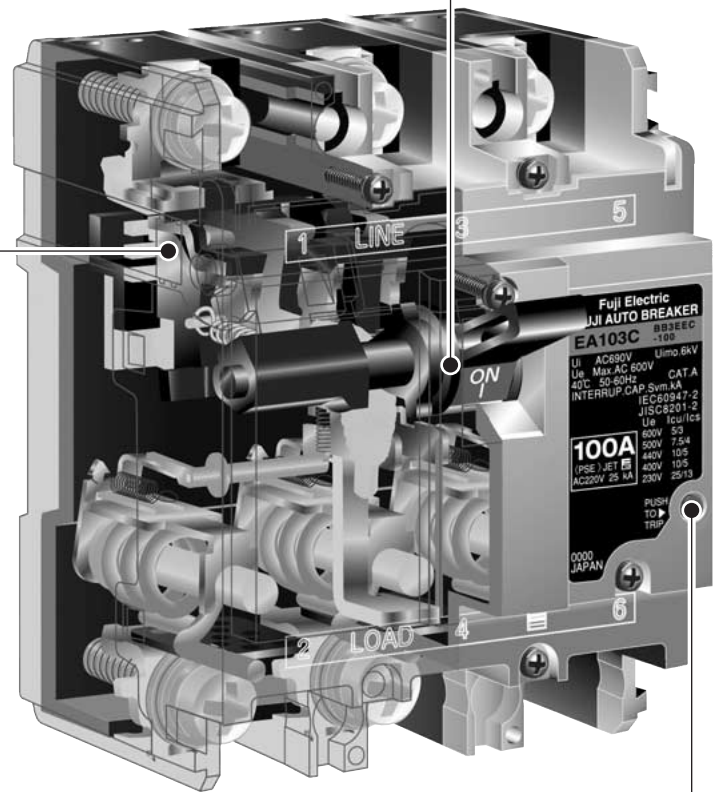
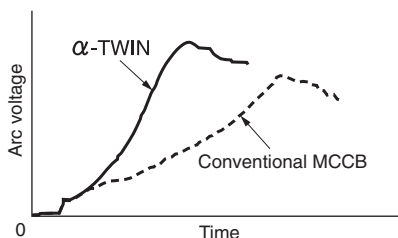

Trip button

The MCCB can be mechanically tripped externally.

Molded Case Circuit Breakers

Design features

Model configuration

Model configuration

Standardization of the main dimensions of the MCCB's has a large effect on panel design, manufacturing and appearance.

Modular construction

Standardized modular construction
30AF to 800AF α -TWIN Breakers standardized basic dimensions — panel design and cutouts are simplified for manufacturing cost savings. The number of mounting space sizes for the 30AF to 800AF S and E series models has been reduced to 5. New α -TWIN Breakers are available in two standard depths: 60 and 103mm, choose it from two front panel cutout height of 52mm or 92mm. The operating handle is at the center of the breaker and its panel cutout for eased panel design, manufacture, and mounting are easy. Terminal height above the panel of models 30AF to 225AF is standardized at 24mm to ease wiring.

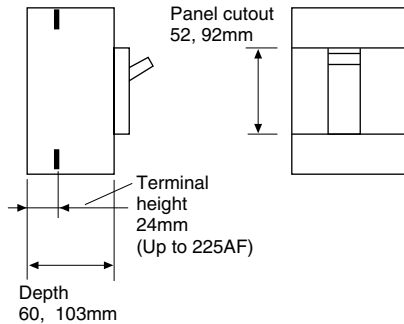

Side-by-side installation

A pole width of 25mm was selected for distribution panel breakers and economy type general-purpose breakers with frame size of 100A and smaller. Therefore, extremely rational procedures can be devised for panel machining and wiring.



Thin terminal block

The terminal block for internal accessory is now thinner (1/2 the size of conventional type). Thus, the space between breakers has been reduced to less than 1/3 that required by conventional type. (EA100AF or smaller)

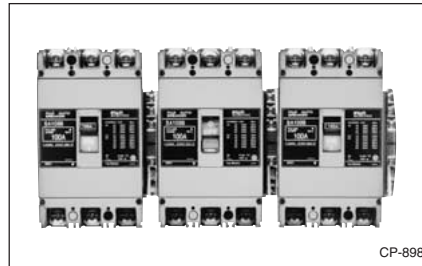

Compact and lightweight

These breakers are more compact and lightweight than those of the old series. Photos are a comparison of new EA103C breakers and old EA103B.

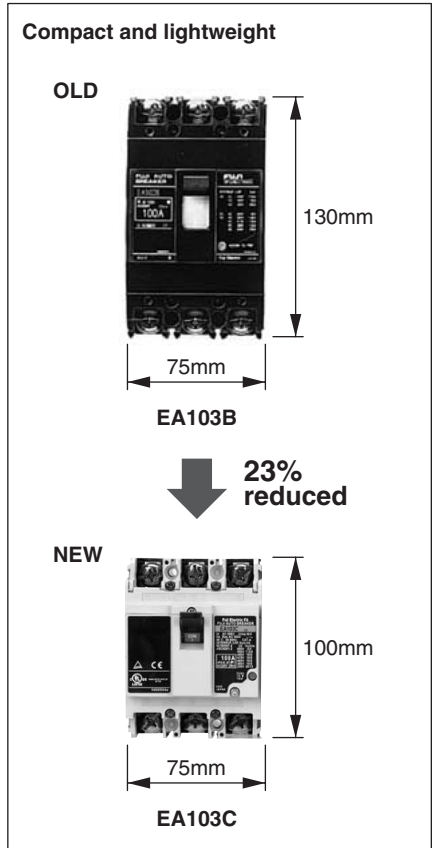

The standardization of depths reduces the number of frame sizes from 6 to 5.

Conventional series dimensions (30AF to 800AF)

| | | | | | | (mm) | |
|---|---|--------------------|--------------------|--------------------|---|----------------------------|--------------------------------------|
| | | | | | | | |
| EA30 EA50A EA100F | SA30B SA50B SA50R SA60B SA60R | SA100BA SA100RA | SA225BA SA225RA | SA400B SA400R | SA600R SA800R | EA50B EA60B EA100B | EA225B EA400B EA600B EA800B |
| | | | | | | ↓ | |
| α-TWIN series dimensions | | | | | | | |
| | | | | | | | |
| SA30C SA50C SA50RC SA60C SA60RC | SA103C SA103RC | SA225C SA225RC | SA400C SA400RC | SA600RC SA800RC | EA30AC EA50AC EA50C EA60C EA100AC EA100C | EA400C EA600C EA800C | |

Note : The figures show the dimensions of three-pole models

■ Front mounting front connection

4 main types of terminals are as shown in the photos. Terminal screws are self-lifting, pan-head screw, hexagonal socket head screw and flat terminal which are tighten because bolts are used.

Terminals vary according to the current capacity of each type of housing. All breaker terminals should be connected to copper crimp connectors or copper bus bars. Never connect to aluminium conductors, since overheating can be expected.

Self-lifting terminal



Screw terminal (Pan-head bolt)

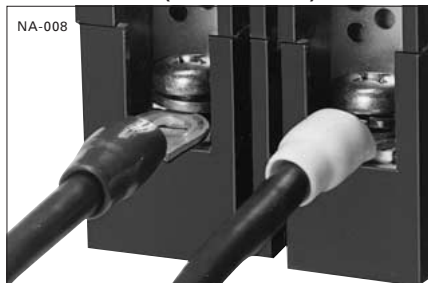

Screw terminal (Hexagonal socket head bolt)



Flat terminal

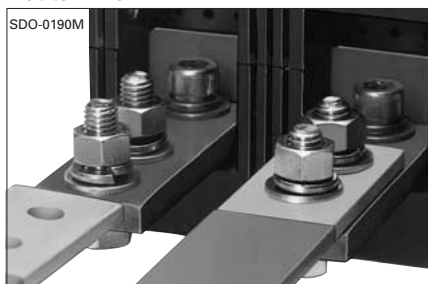

Terminal covers

Since the live conductors are exposed at the MCCB terminals there is the danger of accidental contact.

A terminal cover can be provided where necessary.

For further information refer to page 06 /128.

Short type

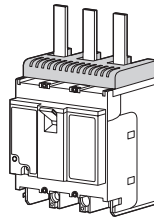

Long type

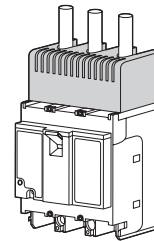

Modular design — Up to 225AF E and S series (α-TWIN series)

Since molded cases generally have common dimensions and outlines they can easily be installed on distribution boards in uniform neat groupings, with switches lined up in a row. E and S series up to 225AF are built on the modular system. For instance the depth is 60mm while the panel cutout height of 52mm. The standardization of the MCCBs and panel board allows the speed up of assembling and wiring of the panel and permits panel surface processing to be carried out in a shorter period of time.

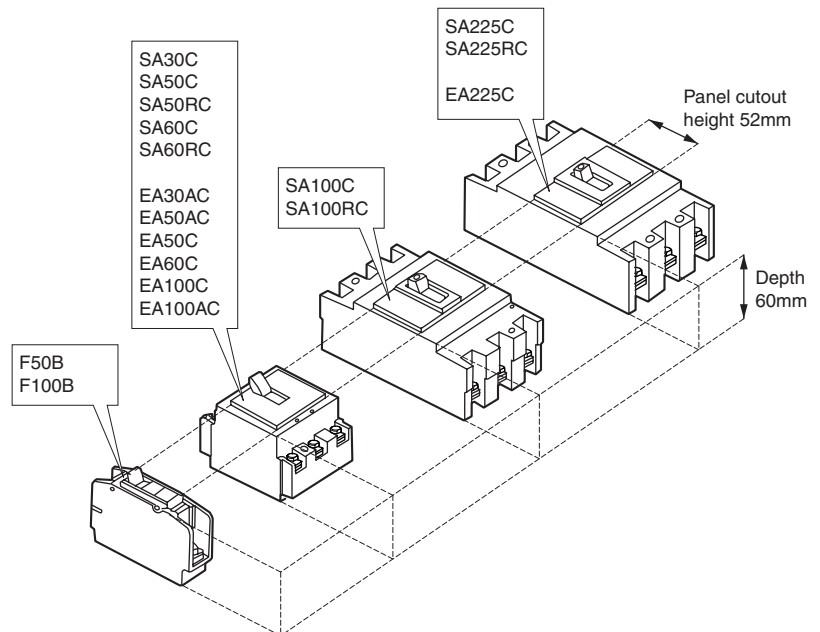

Molded Case Circuit Breakers

Design features

Accessories

■ Internal and external accessories A wider range of customer-mountable accessories

The range of cassette-type internal accessories has been greatly expanded for α -TWIN MCCBs. This speeds up and simplifies customer response to specification changes. All accessories shown here can be mounted by the customer except for motor operating mechanism and plate type padlocking device.

Wide variety of internal accessory combinations

Up to two auxiliary switches, two alarm switches, and one shunt trip device or undervoltage trip device quickly snap on or in.

Quick and easy mounting

No need to open breaker cover to mount accessories. Internal accessories easily snap into a pocket at the left of the breaker window frame.

No adjustments

Accessory mounting is quick and easy — accessories adjust automatically at the correct position when mounted.

Two ways to connect — lead wires or terminal blocks

• Lead wire types

Leads are marked with to indicate the correct terminal number of the accessory — incorrect wiring is minimized. To make wiring easy and prevent to incorrect connection, the lead wires are provided with color coated tube and marking on it.

• Terminal block types

Terminal blocks are mounted on the side of the breaker case. Blocks are only 12.5 or 19mm thick, minimizing panel mounting space. Installed lead wires are parallel to the side of the case.

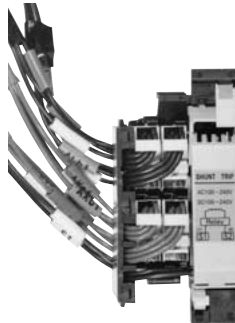

AF93-82

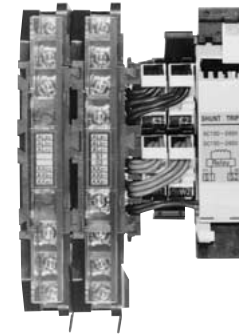

AF93-81

| | | | | |
|---|---|--|--|---------------------------|
| Alarm switch | Auxiliary switch | Shunt trip device | Undervoltage trip device | Terminal block |
| Terminal covers Long type Short type | Insulation barriers Interphase barrier Earth barrier | Motor operating mechanism | Mechanical interlocking device | |
| Steel enclosure | Handle padlocking device Handle locking cover | Operating handles N type V type | Modification kits For front mounting, rear connection For plug-in mounting For flush mounting, rear connection | |