

Molded Case Circuit Breakers

Dimensions

S series/3, 4-pole

■ Dimensions, mm

● Front mounting, front connection

SA1603E, SA1604E

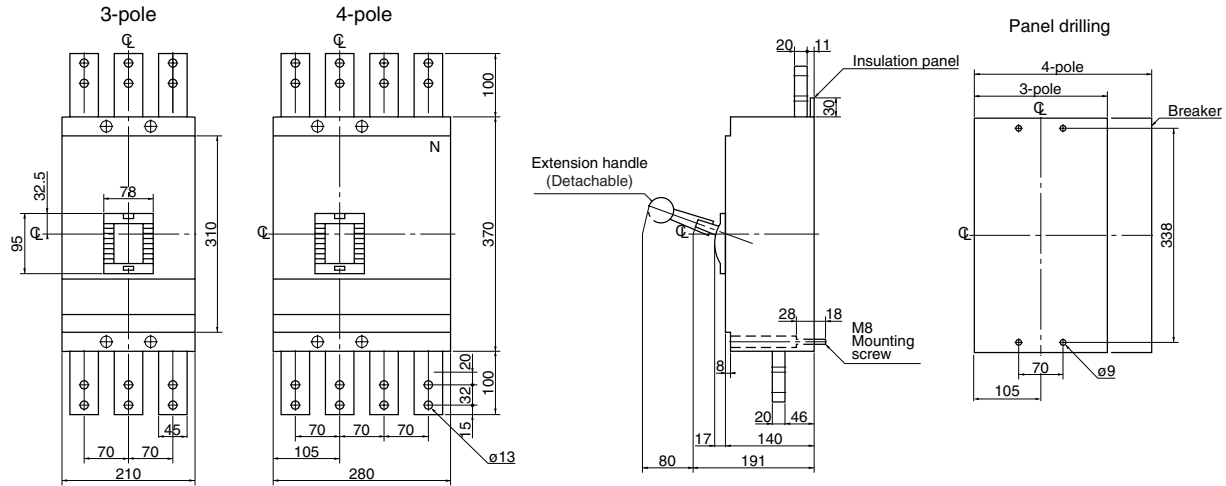

SA54B

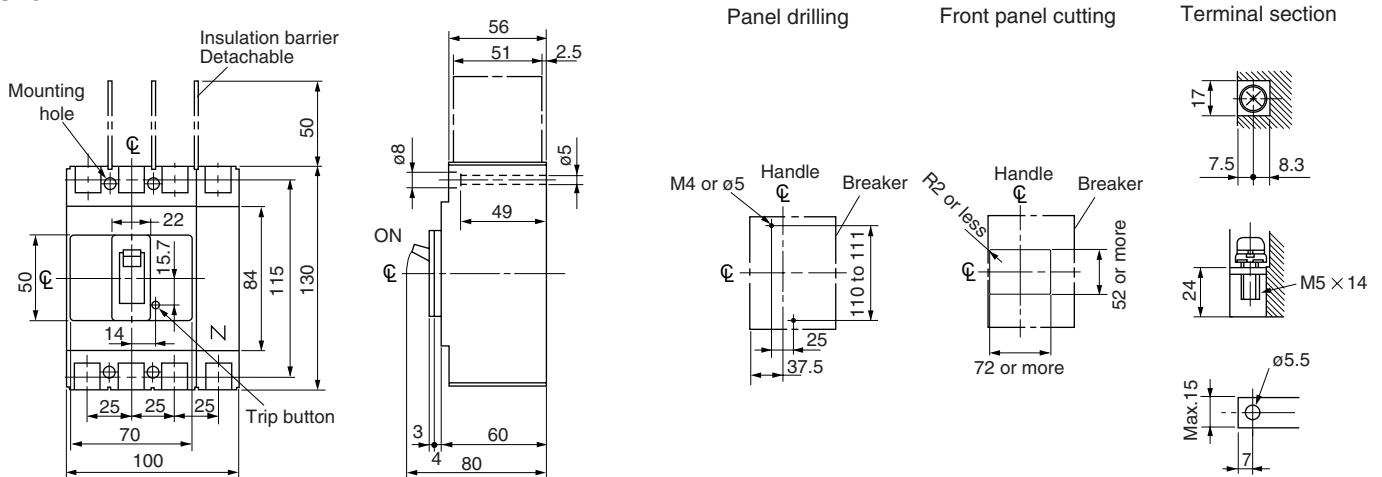

SA104R

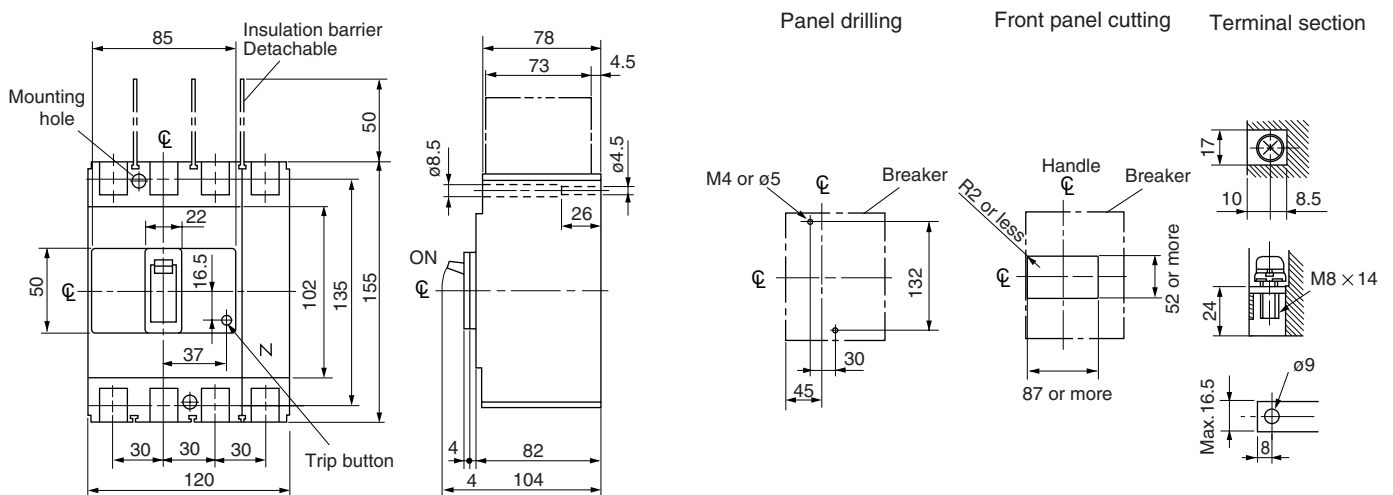

Molded Case Circuit Breakers

Dimensions

S series/4-pole

■ Dimensions, mm

● Front mounting, front connection

SA204R

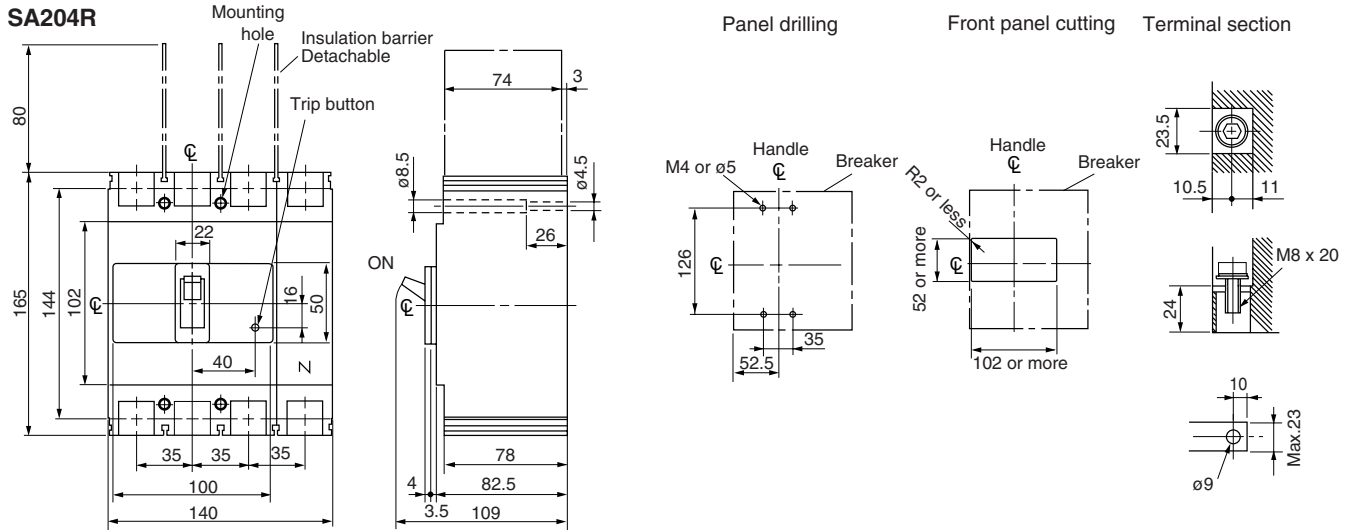

SA404HA

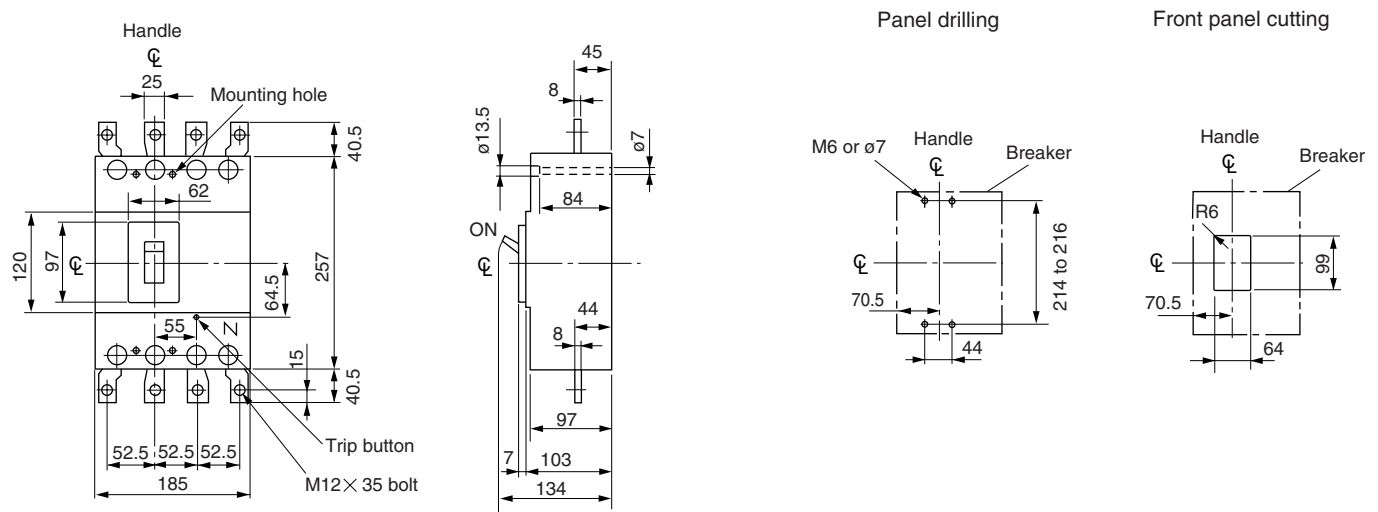

SA604H, 804H

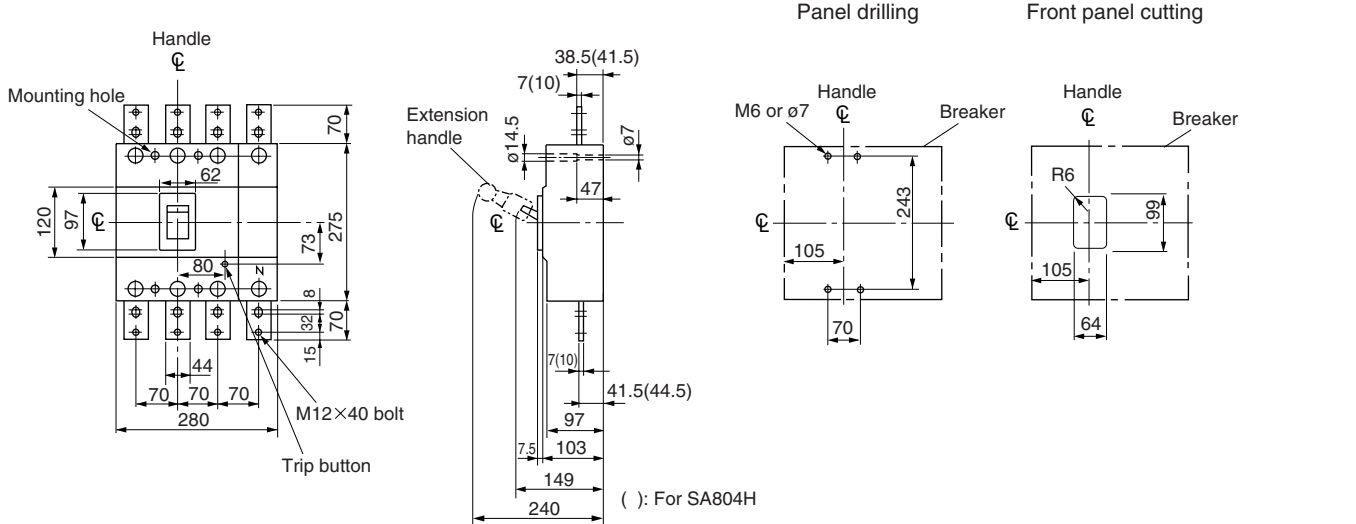

Molded Case Circuit Breakers

Dimensions

E series/2, 3, 4-pole

■ Dimensions, mm

● Front mounting, front connection

EA803C □ -CE

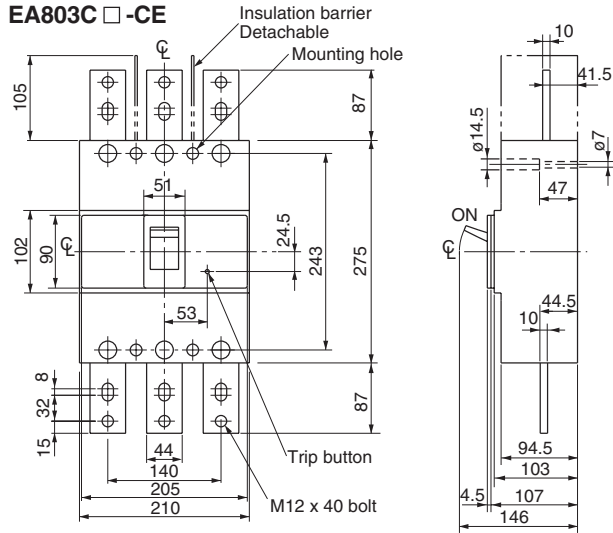

Panel drilling

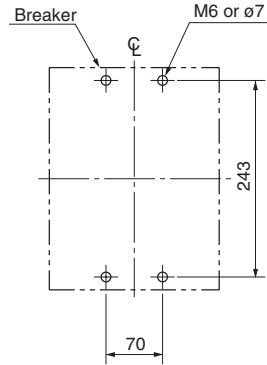

Front panel cutting

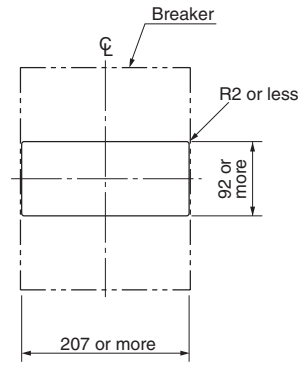

EA104B

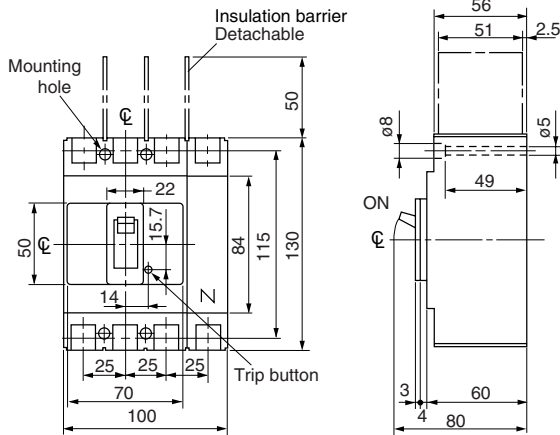

Panel drilling

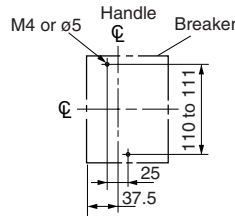

Front panel cutting

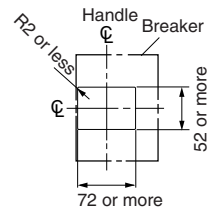

Terminal section

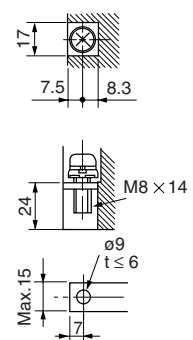

● Front mounting, rear connection (type X)

EA32AC □ -CE, 52AC □ -CE, 52C □ -CE

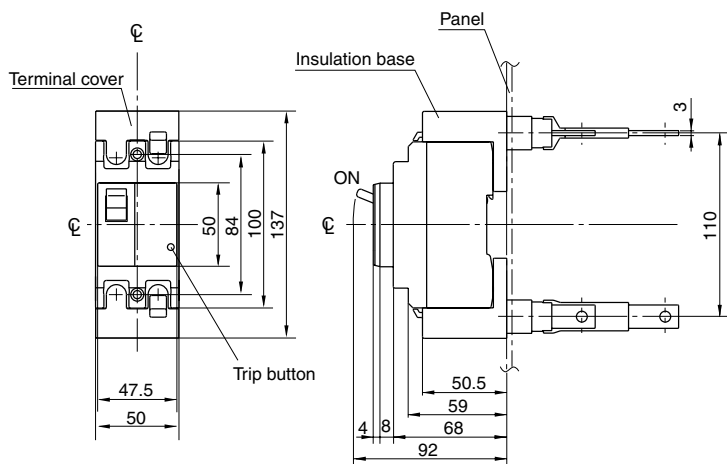

Panel drilling

