

Earth Leakage Circuit Breakers

Type number nomenclature

■ Type number nomenclature

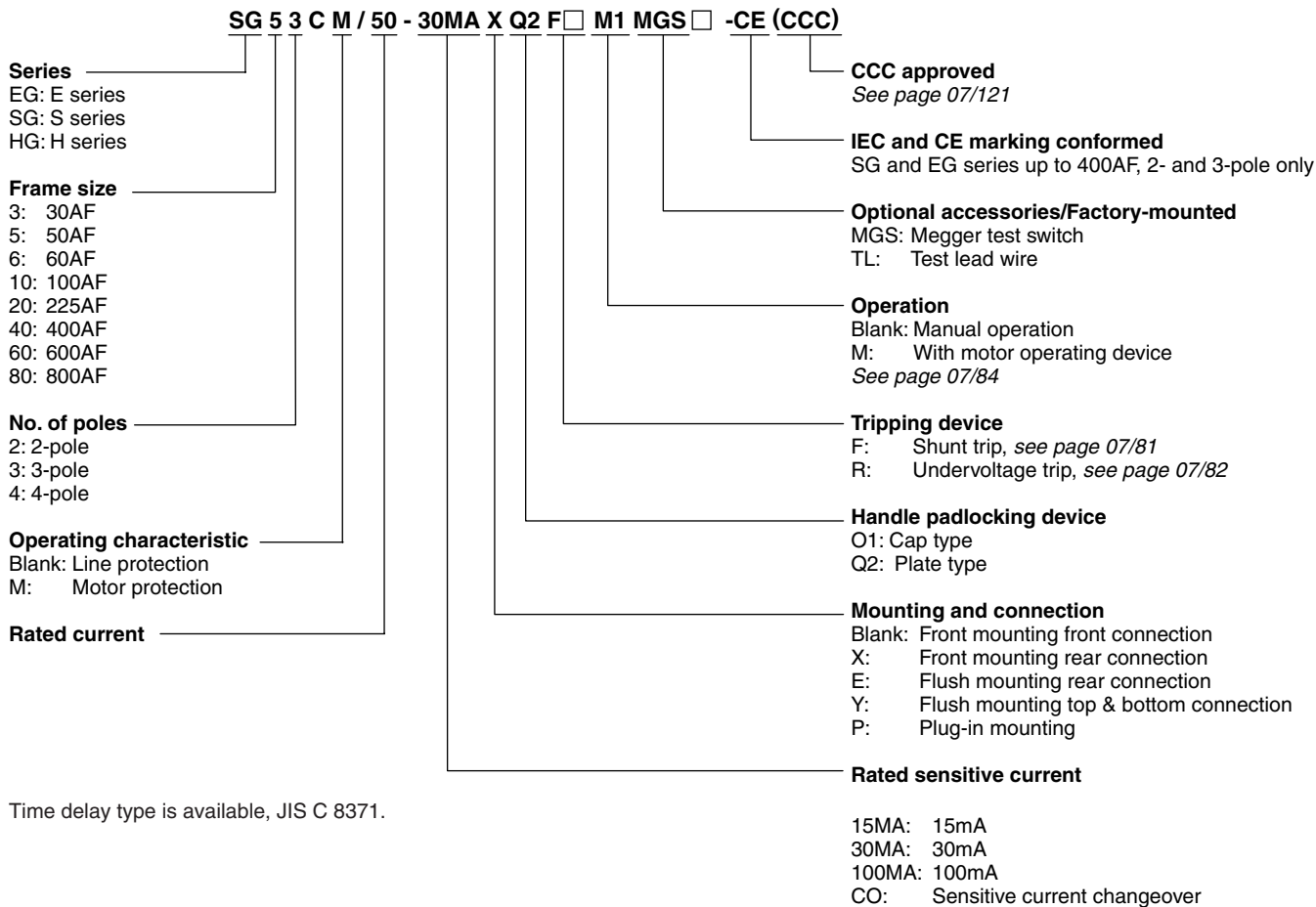

Time delay type is available, JIS C 8371.

• These ELCBs are pollution degree 2.

■ Ordering information

Specify the following:

1. Type number of ELCB including factory-mounted optional accessories
2. Type number of customer-mountable optional accessories

■ Customer-mountable optional accessories/Sold separately

Internal accessories

Auxiliary switch, alarm switch, shunt trip device (except for SG100, SG225, EG225), undervoltage trip device (except for SG100, SG225, EG225), terminal block

External accessories

Operating handles (N, V and G-type), terminal covers, insulation barrier, steel enclosures, handle locking covers, kits for mounting modification, flat terminal, mechanical interlock device

■ Factory-mounted optional accessories

External accessories

Handle padlocking devices/Q1 and Q2, motor-operating mechanism/M, megger test switch/MGS, test lead wire/TL

Further information: See pages 07/68.

■ **Type number nomenclature / UL489 approved**

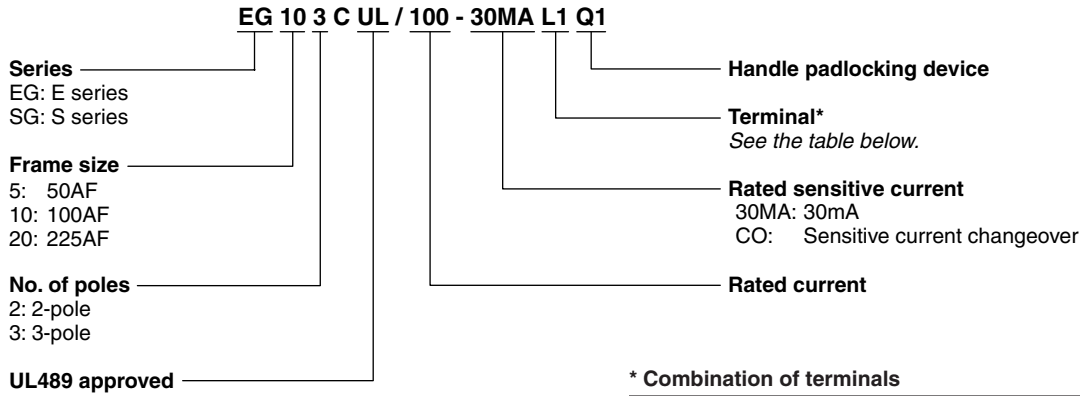

* **Combination of terminals**

Code	Terminal position		Applicable ELCB type		
	Line side	Load side	SG53RCUL	SG103CUL	SG403CUL
				EG102CUL	SG203CUL
				EG103CUL	
Blank	Screw	Screw	●	●	—
L1	Flat terminal	Flat terminal	●	●	●
L3	Screw	Flat terminal	●	●	—
L4	Flat terminal	Screw	●	●	—
L5	Screw	Block terminal	—	●	—
L6	Block terminal	Screw	—	●	—
L7	Flat terminal	Block terminal	—	●	●
L8	Block terminal	Flat terminal	—	●	●

● : Available — : Not available

Note: •When using both a flat terminal and terminal cover for SG103CUL and 203CUL, the terminal cover for the flat terminal is required.
 •For SG50RCUL and EG100CUL, use an insulation barriersupplied.
 Terminal cover is not available.

■ **Ordering information**

- Specify the following:
1. Type number of ELCB including factory-mounted optional accessories
 2. Type number of customer-mountable optional accessories

■ **Customer-mountable optional accessories/Sold separately**

Internal accessories

Auxiliary switch, alarm switch, shunt trip device, undervoltage trip device, terminal block

External accessories

Operating handles (N and V-type), terminal covers, insulation barrier, steel enclosures, handle locking covers, kits for mounting modification, flat terminal, mechanical interlock device