

Air Circuit Breakers

DH series

Closing method

■ Closing method

With DH series ACB, there are two kinds of closing methods; manual charging type and motor charging type.

● Manual charging type

With manual charging type DH series ACB, the closing springs are charged manually by means of the spring charging handle. The ON/OFF operation of ACB is performed by ON/OFF buttons on the ACB.

• Charging the closing springs

The closing springs are charged manually by pumping the spring charging handle.

• Closing the ACB

Pressing the ON button on the ACB closes the ACB.

• Opening the ACB

Pressing the OFF button on the ACB opens the ACB. The ACB cannot be closed as long as the OFF button is pressed.

● Motor charging type

With motor charging type DH series ACB, the closing springs are charged by a motor. The ON/OFF operation of ACB is performed remotely. The DH series ACB is also equipped with a manual charging mechanism to facilitate inspection

and maintenance work. The electronized control circuit promises optimum control to the charging of the closing spring and ACB ON/OFF operation.

• Charging the closing springs

The closing springs are automatically charged by a motor. When the closing springs are released with the ACB turned on, they are automatically charged again by the motor in preparation for the next ON operation.

• Closing the ACB

Turn on the remote ON switch to close the ACB. As the anti-pumping mechanism is equipped, even if the ON switch is turned on continuously, the ACB's closing operation is performed only once. When the ACB has to be closed again, turn off the ON switch to reset the anti-pumping mechanism, turn on the ON switch after the closing springs charge completed. If the ON and OFF signals are simultaneously given to the ACB, the ON signals are ignored.

• Opening the ACB

With AGR-11 OCR or without OCR, to open the ACB remotely, use the shunt trip device (see page 08/57), or the undervoltage trip device (see page 08/58). With AGR-21 OCR, the ACB can be electrically turned off by turning on the external OFF switch to excite the tripping coil TC. The tripping coil TC is equipped as standard.

● Operatin power supply

With AGR-11 OCR or without OCR

Rated voltage (V)	Applicable voltage range (V)		Operation power supply ratings		
	CHARGE/ ON operation	OFF operation *1	Motor inrush current (peak) (A)	Motor steady-state current (A)	Closing command current (peak) (A)
100 AC	85-110		6	0.8	0.48
110 AC	94-121		6	0.8	0.39
120 AC	102-132		6	0.8	0.37
200 AC	170-220		8	0.7	0.24
220 AC	187-242		8	0.7	0.19
240 AC	204-264		8	0.7	0.18
24 DC	20-26		12	3.5	1.65
48 DC	41-53		9	1.4	0.86
100 DC	85-110		5	0.7	0.39
110 DC	94-121		5	0.7	0.37
125 DC	106-138		5	0.7	0.31
200 DC	170-220		6	0.5	0.19
220 DC	187-242		6	0.5	0.18

Note: *1 For the ratings of the shunt trip device, see page 08/57.

With AGR-21 OCR

Rated voltage (V)	Applicable voltage range (V)		Operation power supply ratings		
	CHARGE/ ON operation	OFF operation	Motor inrush current (peak) (A)	Motor steady-state current (A)	Closing command current (peak) (A)
100-120 AC	85-110	70-132	6	0.8	3.0
200-240 AC	170-264	140-264	8	0.7	3.5
24 DC	18-26	17-26	12	3.5	7.0
48 DC	36-53	34-53	15	3.0	9.0
100-125 DC	75-138	70-138	5	0.7	2.5
200-250 DC	150-275	140-275	6	0.5	3.0

● Step-down transformer (separately installed)

The maximum rated voltage applicable to the operation power supply is AC240V. If a higher voltage has to be applied, a step-down transformer is needed.

The following step-down transformers are available as options.

Rated control voltage	Transformer		
	Type	Capacity	Voltage ratio
AC410-470V	TSE-30M	300VA	450/220V
AC350-395V	TSE-30M	300VA	380/220V

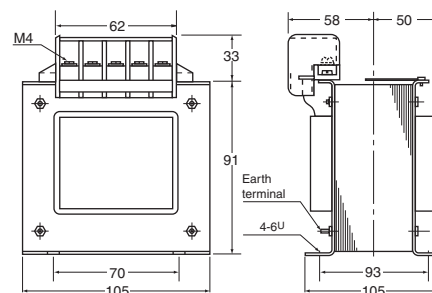

■ Tripping devices

• Continuous rating shunt trip device

The continuous-rating shunt trip device allows the ACB to be opened when an external protection relay against overcurrent or reverse power is activated.

Because of its continuous rating, the device can also be used to provide an electrical interlock to the ACB.

When an AGR-11 OCR is fitted or no OCR is fitted, continuous rating shunt trip and undervoltage trip can not be fitted to the same ACB.

Shunt trip rating (Continuous rating type)

Type	Rated voltage (V)	Operational voltage (V)	Peak excitation current (A)	Normal current (A)	Opening time (max.) (ms)
	100 AC	70–110 AC	0.48	0.32	
	110 AC	77–121 AC	0.39	0.26	
	120 AC	84–132 AC	0.37	0.24	
	200 AC	140–220 AC	0.24	0.16	
	220 AC	154–242 AC	0.19	0.13	
	240 AC	168–264 AC	0.18	0.12	
AVR-1C	24 DC	16.8–26.4 DC	1.65	1.1	40
	48 DC	33.6–52.8 DC	0.86	0.57	
	100 DC	70–110 DC	0.39	0.26	
	110 DC	77–121 DC	0.37	0.25	
	125 DC	87.5–137.5 DC	0.31	0.21	
	200 DC	140–220 DC	0.19	0.13	
	220 DC	154–242 DC	0.18	0.12	

• Capacitor trip device

In using with the continuous rating shunt trip device, the capacitor trip device can be used to trip the ACB within a limited period of 30 sec if large voltage drop occurs due to a power (AC) failure or short-circuit.

When the continuous rating shunt trip device is used with capacitor trip device, “NO” contact of auxiliary switch of ACB should be connected in series, otherwise, the internal damage may occur.

Type	AQR-1
Rated voltage	100-120V AC
Operational voltage range	70 to 110% of rated voltage
Rated frequency	50/60Hz
Rated voltage of shunt trip used	48V DC
Power consumption	100VA

Control circuit

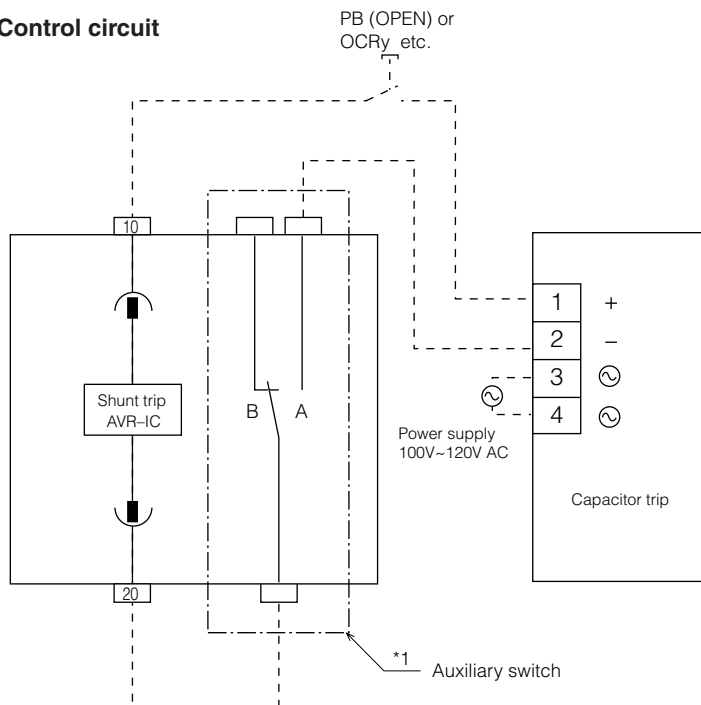

----- User Wiring

*1: Use auxiliary switch for capacitor trip

Dimensions, mm

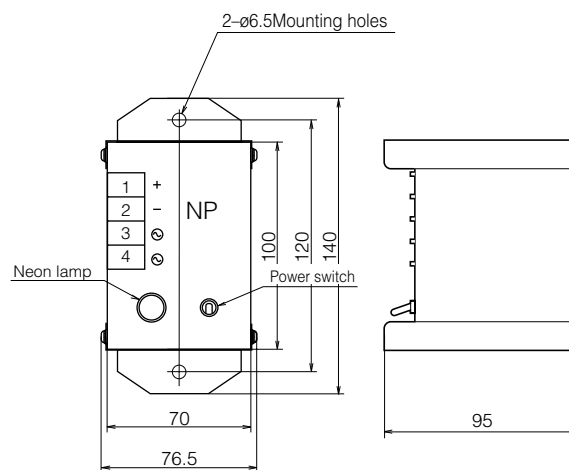

Air Circuit Breakers

DH series

• Undervoltage trip (UVT) (With AGR-11 or without OCR)

The undervoltage trip (UVT) automatically trips the ACB when the control power voltage drops below a pre-determined value. When the control voltage is restored to a value equal to or greater than the pick-up value, the ACB can be closed.

The UVT consists of a trip control device and a tripping mechanism.

Two types of UVT are available. AUR-1BS (instantaneous trip type) and AUR-1BD (500ms time delay type). Remote opening of the circuit breaker by the UVT is possible by connection of a normally open push button across terminals **24** and **30**.

AC undervoltage trip control circuit

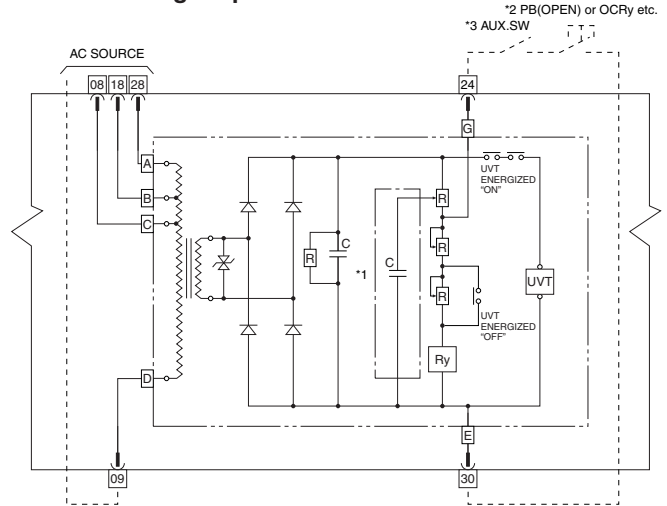

*1 For AUR-1BD only

*2 For tripping command apply minimum 50ms

*3 NO contact of auxiliary switch of ACB to be used.

Ratings

Type of UVT control device	Rated control voltage (V), 50/60Hz	Drop-out voltage (V)	Pick-up voltage (V)	Coil excitation current (A)	Power consumption (VA)	
					Normal	Reset
AUR-1BS	100 AC	35 – 70	85	0.3	30	50
AUR-1BD	110 AC	38.5 – 77	93.5			
	120 AC	42 – 84	102			
	200 AC	70 – 140	170			
	220 AC	77 – 154	187			
	240 AC	84 – 168	204			
	380 AC	133 – 266	323			
	415 AC	145 – 290	352			
	440 AC	154 – 308	374			

* 24V DC UVT also available as special specification.

UVT control device can be installed separately from the ACB body.

2m lead wire is provided to connect the UVT control device with the ACB.

Dimensions, mm

UVT control device (separately installed)

