

**SW type wide-angle indicating switchboard instruments**

**■ Description**

SW-type meters are used in many industrial applications such as switchboards, supervisory panels, metal-clad switchgear and control desks. These are compact in size and easy to read. Scales have equal intervals and indicate through a 240° angle, a feature which distinguishes them from the conventional meters. Meters can be read at a distance, since instrument surfaces are protected by a non-reflecting glass and are not affected by reflections from room lighting. Ammeters are provided with an overload scale in red. The moving parts such as the pointer and moving mechanism employ the span-band (taut-band) suspension system, so that there is

complete freedom from sticking mechanisms, and meters are highly sensitive with resistance to vibration and shock. These instruments comply with the requirements of JIS C1102 and are highly reliable. They can withstand a great deal of abuse in use because of their rugged construction.

**■ Features**

- Span-band suspension system  
Freedom from pivots eliminates such troubles as pointer sticking, and gives the meters excellent vibration and shock resistance.
- High accuracy  
External magnetic fields cannot influence readings.
- Accuracy class: 1.5
- Easy-to-read long-scales and pointer-indications can easily be read from a distance.

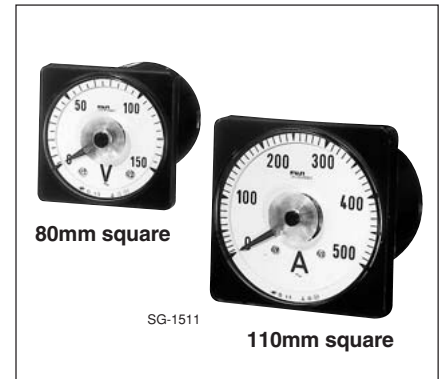

- 110 × 110mm and 80 × 80mm front frame sizes.
- Easily secured by means of two stud bolts.
- Auxiliary equipment such as shunt, impedance box and series resistor is available.

Meter	Description	110mm square Type (Ordering code)	80mm square Type (Ordering code)
AC ammeter	For direct connection Measuring range    Extended range type (0–X–3X) 0 – 0.5A            0 – 0.5 – 1.5A 0 – 1                0 – 1 – 3 0 – 3                0 – 3 – 9 0 – 5                0 – 5 – 15 0 – 7.5             0 – 7.5 – 22.5 0 – 10              0 – 10 – 30 0 – 15              0 – 15 – 45 0 – 20              0 – 20 – 60 0 – 30              0 – 30 – 90	<b>SWR-3</b> (WM3013-□■)  □: Measuring range 0.5A: M50, 1A: 001 to 30A: 030  ■: Range extension No extension: Blank 3X: 3	<b>SWR-6</b> (WM3016-□■)
	For connection to CT CT ratio    Measuring range    Extended type (0–X–3X) 10/5A    0 – 10A            0 – 10 – 30A 15/5    0 – 15             0 – 15 – 45 20/5    0 – 20             0 – 20 – 60 30/5    0 – 30             0 – 30 – 90 40/5    0 – 40             0 – 40 – 120 50/5    0 – 50             0 – 50 – 150 60/5    0 – 60             0 – 60 – 180 75/5    0 – 75             0 – 75 – 225 100/5   0 – 100            0 – 100 – 300 150/5   0 – 150            0 – 150 – 450 200/5   0 – 200            0 – 200 – 600 300/5   0 – 300            0 – 300 – 900 400/5   0 – 400            0 – 400 – 1200 500/5   0 – 500            0 – 500 – 1500 600/5   0 – 600            0 – 600 – 1800 750/5   0 – 750            0 – 750 – 2250 800/5   0 – 800            0 – 800 – 2400	<b>SWR-3</b> (WM3013-□■○)  10: 010, 15: 010, 20: 020 □: Measuring range 30A: 030 to 800A: 800  ■: Range extension No extension: Blank 3X: 3, 5X: 5  ○: CT secondary current 5A: C 1A: C1	<b>SWR-6</b> (WM3016-□■○)

**■ Ordering information**

- Specify the following:
1. Type number (Ordering code)
  2. Measuring range
  3. Supply voltage and frequency
  4. Connection (When connecting to VT or CT, specify VT ratio or CT ratio)

**Example**

- Ammeter
- AC ammeter, front frame 110 × 110 (mm)
  - Measuring range: 0 – 60A
  - Extended range: 60 – 180A
  - For connection to CT: CT ratio 60/5

Type number: SWR-3-60A-X3-/C  
(Ordering code: WM3013-0603C)

# Switchboard Instruments

## SW type

Meter	Description	110mm square Type (Ordering code)	80mm square Type (Ordering code)
AC voltmeter	For direct connection Measuring range 0 – 50V 0 – 75 0 – 100 0 – 150 0 – 300 0 – 600  Operating principle: Rectifier type  Power consumption: 0.5 VA	<b>SWR-3</b> (WM3023-□)  □: Measuring range 50V: 050 to 600V: 600	<b>SWR-6</b> (WM3026-□)
	For connection to VT VT ratio      Measuring range 440/110V      0 – 600V 3300/110      0 – 4.5kV 6600/110      0 – 9kV  Operating principle: Rectifier type  VT ratio: Y/110 (Y: VT primary voltage)  Measuring range: $0 - \frac{1.5}{1.1} \times Y$  Power consumption: 0.5VA	<b>SWR-3</b> (WM3023-□P)  □: Measuring range 400V: 400, 600V: 600, 9kV: 09K	<b>SWR-6</b> (WM3026-□)
DC ammeter	For direct connection Measuring range 0 – 1mA    0 – 200mA    0 – 10A 0 – 3      0 – 500      0 – 15 0 – 5      0 – 1A        0 – 20 0 – 10     0 – 1.5       0 – 30 0 – 20     0 – 2 0 – 50     0 – 3 0 – 100    0 – 5  Operating principle: Moving coil type  Internal resistance: 1mA: Approx. 220Ω 3mA: Approx. 33Ω 5mA: Approx. 10Ω 10mA: Approx. 5Ω 20mA and above: Approx. 60mV	<b>SWM-3</b> (WM3053-□)  □: Measuring range 1mA: 01M to 5mA: 05M 10mA: M01 to 500mA: M50 1A: 001 to 30A: 030	<b>SWM-6</b> (WM3056-□)
	For connection to shunt Measuring range 0 – 50A    0 – 600A      0 – 3000A 0 – 75     0 – 750        0 – 4000 0 – 100    0 – 1000      0 – 5000 0 – 200    0 – 1200      0 – 7500 0 – 300    0 – 1500 0 – 500    0 – 2000  Operating principle: Moving coil type  Shunt ratings: 60mV  Shunt lead wire 1.5m is provided.	<b>SWM-3</b> (WM3053-□S)  □: Measuring range 50A: 010 to 500A: 500 1000A: 10X to 7500A: 75X	<b>SWM-6</b> (WM3056-□S)
DC voltmeter	For direct connection Measuring range 0 – 10V    0 – 150V 0 – 30     0 – 300 0 – 50     0 – 500 0 – 75     0 – 600 0 – 100  Operating principle: Moving coil type  Power consumption: 1mA	<b>SWM-3</b> (WM3063-□)  □: Measuring range 10A: 010 to 600A: 600	<b>SWM-6</b> (WM3066-□)
	For connection to series resistor Measuring range 0 – 750V 0 – 1000 0 – 1500 0 – 2000  Operating principle: Moving coil type  Power consumption: 2mA	<b>SWM-3</b> (WM3063-□B)  □: Measuring range 750V: 750, 1000V: 10X to 2000V: 20X	<b>SWM-6</b> (WM3066-□B)

### ■ Ordering information

Specify the following:

1. Type number (Ordering code)
2. Measuring range
3. Supply voltage and frequency
4. Connection (When connecting to VT or CT, specify VT ratio or CT ratio)

### Example

Voltmeter

- DC voltmeter, front frame 80 × 80 (mm)  
Measuring range: 0 – 150V

Type number: SWM-6-150V  
(Ordering code: WM3066-150)

- AC voltmeter, front frame 110 × 110 (mm)  
Measuring range: 0 – 600V  
For connection to VT

Type number: SWR-3-600V/P  
(Ordering code: WM3023-600P)

Meter	Description	Operating principle: Frequency/DC transducing type	110mm square Type (Ordering code)	80mm square Type (Ordering code)
Frequency meter	Measuring range 45 – 55Hz 110V 55 – 65Hz 110V 45 – 55Hz 220V 55 – 65Hz 220V	Power consumption: 1.4VA at 110V 2.6VA at 220V	<b>SWP1-3</b> (WM3163-□■)	<b>SWP1-6</b> (WM3166-□■)
Single-phase 2-wire wattmeter	For connection to VT and CT Measuring range 0 – ZkW $Z = 0.5 \times \frac{X}{5} \times \frac{Y}{110}$ Z: kWatt X: CT primary current Y: VT primary voltage	Operating principle: Power/DC transducing type Power consumption Current coil: 0.2VA (at 5A) Voltage coil: 3VA (at 110V)	<b>SWC-3</b> (WM3103 -□KW■H●5)	<b>SWC-6</b> (WM3106 -□KW■H●5)
3-phase 3-wire wattmeter	For connection to VT and CT Measuring range 0 – ZkW $Z = \frac{X}{5} \times \frac{Y}{110}$ Z: kWatt X: CT primary current Y: VT primary voltage	Operating principle: Power/DC transducing type Power consumption Current coil: 0.2VA per element (at 5A) Voltage coil: 3VA per element (at 110V)	<b>SWC2-3</b> (WM3113-□KW■H●5)	<b>SWC2-6</b> (WM3116 -□KW■H●5)
3-phase 3-wire varmeter	For connection to VT and CT Measuring range 0 – Zkvar $Z = \frac{X}{5} \times \frac{Y}{110}$ Z: kvar X: CT primary current Y: VT primary voltage	Operating principle: Reactive power/DC transducing type Power consumption Current coil: 0.2VA per element (at 5A) Voltage coil: 3VA per element (at 110V)	<b>SWC2-3</b> (WM3113 -□KV■H●5)	<b>SWC2-6</b> (WM3116 -□KV■H●5)
3-phase 4-wire wattmeter, varmeter	For connection to VT and CT Measuring range 0 – ZkW 0 – Zkvar $Z = \frac{X}{5} \times \frac{Y}{110}$ Z: kWatt or kvar X: CT primary current Y: VT primary voltage	Operating principle: Reactive power/DC transducing type Power consumption Current coil: 0.2VA per element (at 5A) Voltage coil: 3VA per element (at 110V)	<b>SWC3-3</b> (WM3123-□KW■H●5) (WM3123-□KV■H●5)	<b>SWC3-6</b> (WM3126 -□KW■H●5) (WM3126 -□KV■H●5)
3-phase 3-wire power factor meter (for balanced circuit)	For connection to VT and CT VT ratio: = $\frac{Y}{110}$ V CT ratio: = $\frac{X}{5}$ A	Operating principle: Phase angle/DC transducing type Power consumption Current coil: 0.3VA (at 5A) Voltage coil: 1.0VA per phase (at 110V)	<b>SWA1-3</b> (WM3133-H5)	<b>SWA1-6</b> (WM3136-H5)
3-phase 3-wire power factor meter (for unbalanced circuit)	For connection to VT and CT VT ratio: = $\frac{Y}{110}$ V CT ratio: = $\frac{X}{5}$ A	Operating principle: Phase angle/DC transducing type Power consumption Current coil: 0.2VA per phase (at 5A) Voltage coil: 3VA per phase (at 110V)	<b>SWA2-3</b> (WM3143-H5)	<b>SWA2-6</b> (WM3146-H5)
3-phase 4-wire power factor meter	For connection to VT and CT VT ratio: = $\frac{Y}{110}$ V CT ratio: = $\frac{X}{5}$ A	Operating principle: Phase angle/DC transducing type Power consumption Current coil: 0.2VA per phase (at 5A) Voltage coil: 3VA per phase (at 110V)	<b>SWA4-3</b> (WM3153-H5)	<b>SWA4-6</b> (WM3156-H5)

### ■ Ordering information

Specify the following:

1. Type number (Ordering code)
2. Measuring range
3. Supply voltage and frequency
4. Connection (When connecting to VT or CT, specify VT ratio or CT ratio)

### Example

#### Frequency meter

- Front frame 110 × 110 (mm)
- Measuring range: 45 – 55Hz
- Supply voltage: 110V (When connecting to VT, specify VT ratio Y/110)
- Type number: SWP1-3-110V-45-55Hz)
- (Ordering code WM3163-50H)

### 3-phase wattmeter

- Front frame 110 × 110 (mm)
- Measuring range: 0 – 80kW
- For connection to VT and CT
- VT ratio: 440/110, CT ratio: 100/5
- Frequency: 50Hz
- Type number: SWC2-3-80kW-440/110V-100/5A
- (Ordering code WM3113-80kW04H1005)

# Switchboard Instruments

## SW type

### ■ Type number nomenclature

SW M - 3

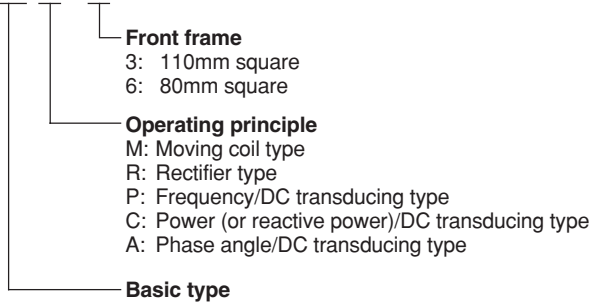

### ■ Accessories

Illustration	Ratings	Ordering code
 <p>Shunt *</p> <p>AFSG-1507</p>	60mV 50A	WM9-60050
	60mV 75A	WM9-60075
	60mV 100A	WM9-60100
	60mV 150A	WM9-60150
	60mV 200A	WM9-60200
	60mV 250A	WM9-60250
	60mV 300A	WM9-60300
	60mV 400A	WM9-60400
	60mV 500A	WM9-60500

\* Lead wire for shunt  
 Two lead wires (each 1.5m in length) are normally provided.  
 When lead wires of over 1.5m in length are required, refer to the following table.

Length (m)	2	3	5.5	9	12.5	22	35
Cross sectional area (mm <sup>2</sup> )	1.25	2	3.5	5.5	8	14	22
Resistance (Ω)	0.06						

### ■ Ordering information

Specify the following:

- Accessory designation
- Ratings  
 (in case of lead wire for shunt, length of lead wire)

### Example

- Shunt for DC ammeter
- Ratings: 60mV, 200A  
 (Ordering code WM9-60200)

■ Dimensions, mm

SWR-3, SWM-3, SWP1-3, SWA1-3

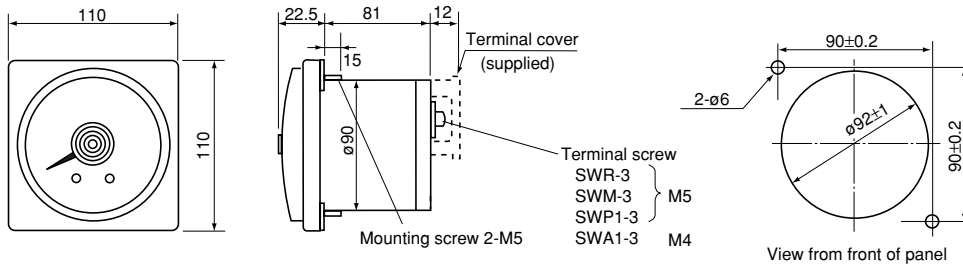

Type	Mass (g)
SWR-3	AC ammeter: 700 AC voltmeter: 700
SWM-3	DC ammeter: 500 DC voltmeter: 500
SWP1-3	530
SWA1-3	720

SWA2-3, SWA4-3, SWC-3, SWC2-3, SWC3-3

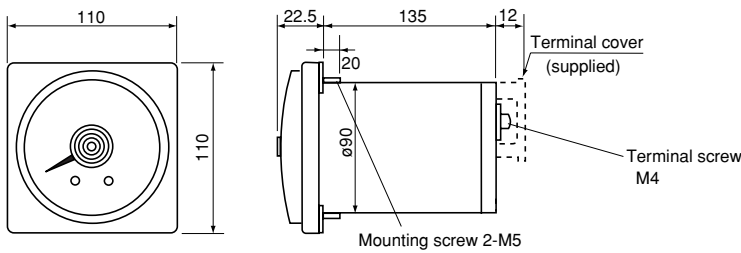

Type	Mass (g)
SWA2-3	750
SWA4-3	850
SWC-3	720
SWC2-3	720
SWC3-3	720

Panel cutting:  
Same as above

SWR-6, SWM-6, SWP1-6, SWA1-6, SWA2-6, SWC2-6, SWC-6, SWC3-6, SWA4-6

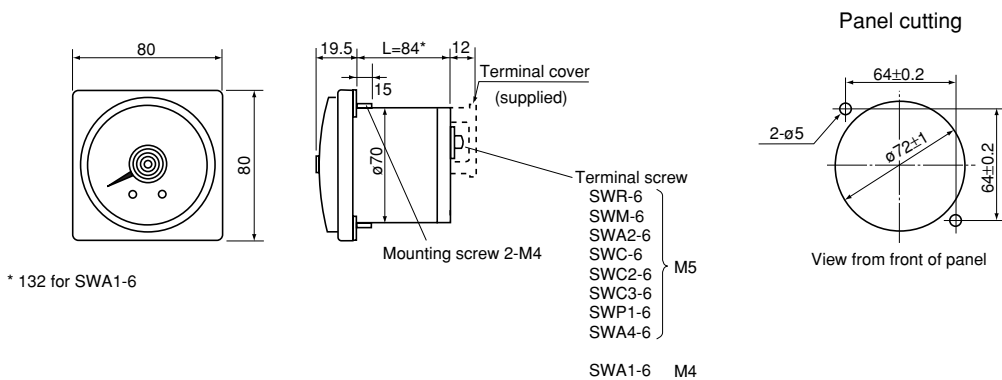

\* 132 for SWA1-6

Type	Mass (g)
SWR-6	AC ammeter: 600 AC voltmeter: 600
SWM-6	DC ammeter: 400 DC voltmeter: 400
SWP1-6	410
SWA1-6	590
SWA2-6	340
SWA4-6	340
SWC-6	340
SWC2-6	340
SWC3-6	340

DC converters for SWC-6, SWC2-6 and SWA2-6 are installed separately.

# Switchboard Instruments

## SW type

### ■ Dimensions, mm

#### Shunt

With base 1 to 75A, 100A

Without base 150, 200A

Without base 250 to 500A

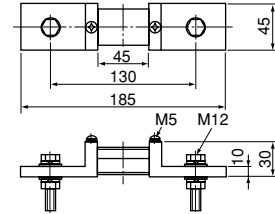
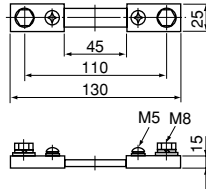
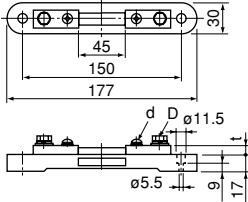

Ratings	D	d	t	Mass (g)
60mV 1-75A	M6	M5	8	270
60mV 100A	M8	M5	10	350

Ratings	Mass (g)
60mV 150A	370
60mV 200A	380

Ratings	Mass (g)
60mV 250A	930
60mV 400A	945
60mV 500A	960

#### Series resistor (for SWM-3, 6)

3-terminal, 750V to 2kV

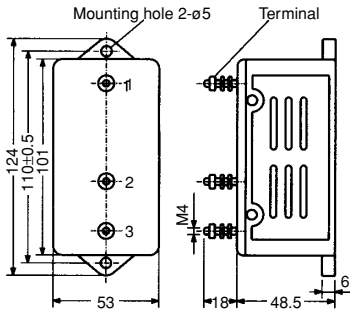

Mass: 250g

#### DC converter for wattmeter, varmeter and power factor meter

SWC-6, SWC2-6, SWC3-6, SWA2-6, SWA4-6

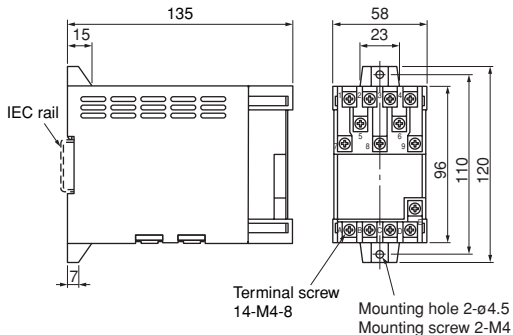

Used with	Mass (g)
SWC-6	580
SWC2-6 (wattmeter)	580
SWC2-6 (varmeter)	650
SWC3-6 (wattmeter)	580
SWC3-6 (varmeter)	650
SWA2-6	650
SWA4-6	750

## ■ Wiring diagrams

**DC ammeter SWM-3, -6  
AC ammeter SWR-3, -6**

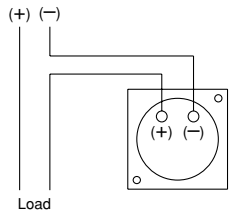

DC ammeter 30A  
AC ammeter 30A  
(+)(-): For DC voltmeter

**DC voltmeter SWM-3, -6  
AC voltmeter SWR-3, -6**

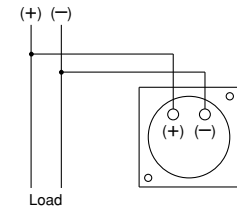

DC voltmeter 600V  
AC voltmeter 600V  
(+)(-): For DC voltmeter

**DC ammeter SWM-3, -6**

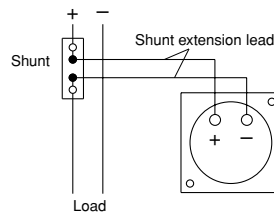

DC ammeter 30A  
In case of 60mV shunt, the turn-round  
resistance of extension lead is 60 milliohms

**DC voltmeter SWM-3, -6**

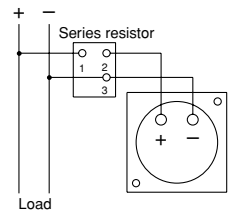

**AC ammeter SWR-3, -6**

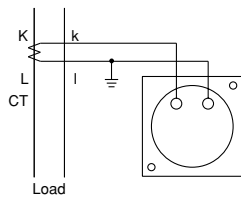

For connection to CT

**AC voltmeter SWR-3, -6**

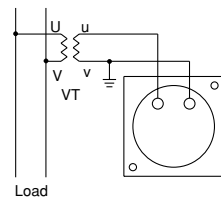

For connection to VT

**Pointer type frequency meter SWP1-3, -6**

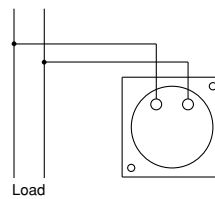

Direct connection

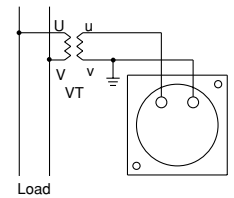

For connection to VT

**Single-phase wattmeter SWC-3**

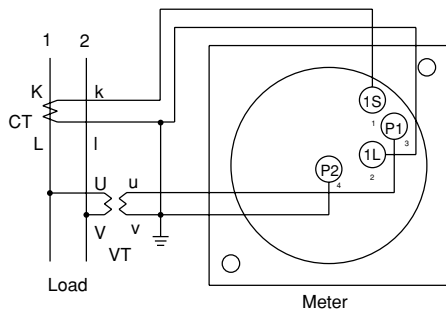

**Single-phase wattmeter SWC-6**

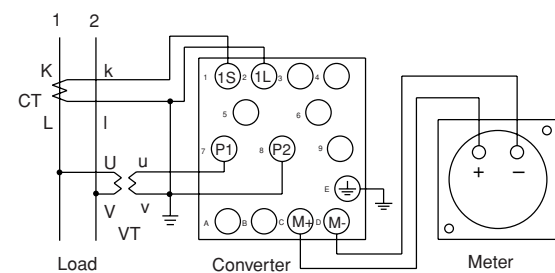

**3-phase wattmeter (varmeter) SWC2-3**

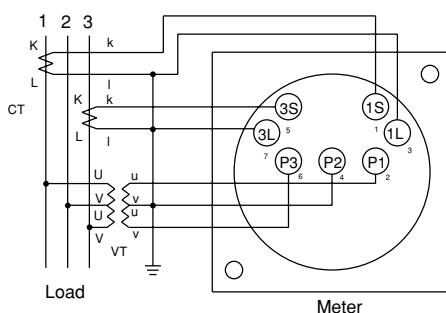

**3-phase wattmeter (Varmeter) SWC2-6**

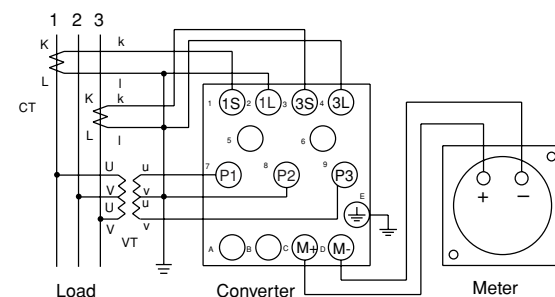

# Switchboard Instruments

## SW type

**3-phase power factor meter SWA1-3, -6**

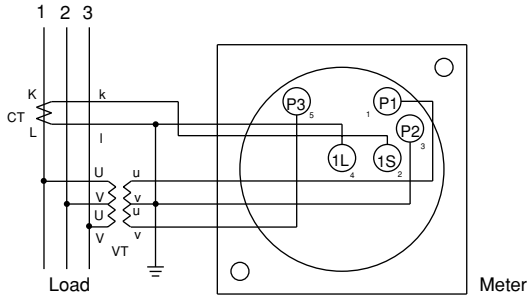

**3-phase power factor meter (for unbalanced circuit) SWA2-3**

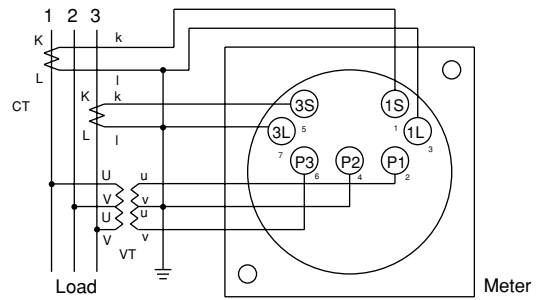

**3-phase power factor meter (for unbalanced circuit) SWA2-6**

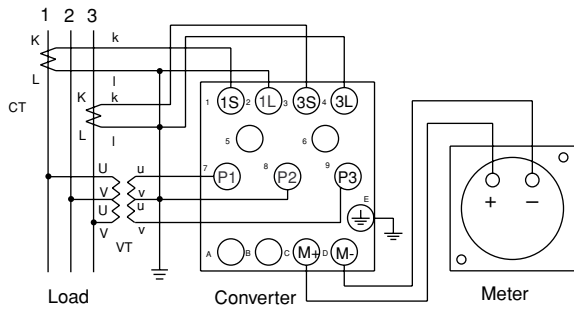

**3-phase 4-wire power factor meter and wattmeter SWA4-6, SWC3-6**

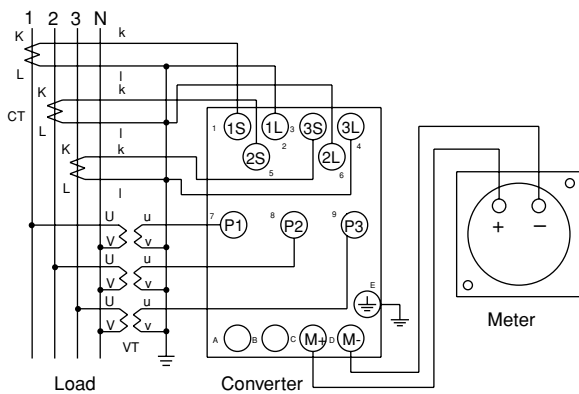

**SWC3-3, SWA4-3**

