

## WE12 power line multi-meters

### ■ Description

WE12 meter handles up to 12 measurements and outputs the results. Abundant functions support managing data for power distribution lines and facilities.

### ■ Features

- Handles up to 12 measurements: Three separate line voltage measurements, three separate phase current measurements, active power, reactive power, power factor, frequency, electric energy (watthour), and reactive electric energy (varhour). Also measures reactive power flow and lead and lag angles for the power factor.
- Digitally displays up to three measurements simultaneously and indicates the value of the measurement on the main monitor with a bar graph.
- Measurements can be switched by pressing a button on the front surface or by external signals.
- The upper limit for a current and the upper and lower limits for a voltage can be preset. Any measured value exceeding these limits will flicker on the display.
- The least significant digit of the digital display can be specified as a dead zone.
- Up to three measurements can be output (optical feature) for centralized monitoring of the system.



- Three types of output are provided: Analog, pulse, and RS-485.
- The standard terminal cover ensures safety by covering charged parts.
- Meters with backlight can also be manufactured.

### ■ Types and ratings

Measurement item	Input circuit	Rated input voltage	Rated input current	Control power supply	Type (Ordering code)*
Voltage, current Active power Reactive power Power factor Frequency Electric energy (watthour) Reactive electric energy (varhour)	3-phase 3-wire	110V AC	5A	85–253V AC/80–143V DC	WE12-311□□□
				20–56V DC	WE12-312□□□
			1A	85–253V AC/80–143V DC	WE12-321□□□
		20–56V DC	WE12-322□□□		
		220V AC	5A	85–253V AC/80–143V DC	WE12-331□□□
				20–56V DC	WE12-332□□□
	1A		85–253V AC/80–143V DC	WE12-341□□□	
	3-phase 4-wire	110/√3 V AC	5A	85–253V AC/80–143V DC	WE12-411□□□
				20–56V DC	WE12-412□□□
			1A	85–253V AC/80–143V DC	WE12-421□□□
		20–56V DC	WE12-422□□□		
		220/√3 V AC	5A	85–253V AC/80–143V DC	WE12-431□□□
20–56V DC				WE12-432□□□	
1A	85–253V AC/80–143V DC		WE12-441□□□		
20–56V DC	WE12-442□□□				
Single-phase 2-wire	110V AC	5A	85–253V AC/80–143V DC	WE12-111□□□	
			20–56V DC	WE12-112□□□	
		1A	85–253V AC/80–143V DC	WE12-121□□□	
	20–56V DC	WE12-122□□□			
	220V AC	5A	85–253V AC/80–143V DC	WE12-131□□□	
			20–56V DC	WE12-132□□□	
1A		85–253V AC/80–143V DC	WE12-141□□□		
20–56V DC	WE12-142□□□				
Single-phase 3-wire	100/200V AC	5A	85–253V AC/80–143V DC	WE12-211□□□	
			20–56V DC	WE12-212□□□	
		1A	85–253V AC/80–143V DC	WE12-221□□□	
			20–56V DC	WE12-222□□□	

Note: \* See page 09/12 for type number nomenclature.

# Switchboard Instruments

## Power line multi-meters

### WE12

#### ■ Measurement and performance

Measurement	Measurement ranges and display specifications	Accuracy *1		Remarks
		Digital display	Analog output *2 Pulse output *2 Transmission output *2	
Voltage	150V to 750kV (24 ranges)	±1.0%±1 digit	±0.5%	Selected by switching R-S, S-T, and T-R line voltages (or R-N, S-N, and T-N phase-voltages).
Current	5.00A to 30.0kA (70 ranges)	±1.0%±1 digit	±0.5%	Selected by switching R, S, and T (or N) phase currents.
Active power	480W to 1000MW (range is determined by voltage and current ranges)	±1.0%±1 digit	±0.5%	Measurement ranges for the analog output can be independently specified from the ranges for display of the measurement value.
Reactive power	Lead/lag 360var to 1000Mvar (range is determined by voltage and current ranges)	±1.0%±1 digit	±0.5%	Measurement ranges for the analog output can be independently specified from the ranges for display of the measurement value.
Power factor	Lead 0.5 to 1 to lag 0.5, or lead 0 to 1 to lag 0 (selection)	±3.0%±1 digit	±3.0%	If the input voltage is below 20% of the voltage range, or if the input current is below 2% of the current range, cos $\phi$ is equal to 1.
Frequency	45 to 55Hz, 55 to 65Hz, or 45 to 65Hz (selection)	±0.5%±1 digit	±0.5%	If the input voltage is below 20% of the voltage range, the measurement output is 0.0Hz. (Lower limit.)
Electric energy (watthour)	Display: 5-digit integer Multiplication factor: 10 <sup>n</sup> (n: integer) Fractions can be partially displayed in decimal form to a maximum of three decimal places. Only electric energy flow is measured.	±2.0% (power factor = 1) ±2.5% (power factor = 0.5)	±2.0% (power factor = 1) ±2.5% (power factor = 0.5)	Conforms to the standard for ordinary watthour meters. See the optional parts specifications for the setting range of units of energy (kWh) per output pulse.
Reactive electric energy (varhour)	Display: 5-digit integer Multiplication factor: 10 <sup>n</sup> (n: integer) Fractions can be partially displayed in decimal form to a maximum of three decimal places. Only (lag) reactive energy flow is measured.	±2.5% (power factor = 0) ±2.5% (power factor = 0.87)	±2.5% (power factor = 0) ±2.5% (power factor = 0.87)	See the optional parts specifications for the setting range of units of reactive energy (kvarh) per output pulse.

Notes: \*1 Due to the measurement system of the meter, the accuracy will decrease if the meter directly measures the output of cycle-control inverters or phase-angle-control SCR inverters.

\*2 The analog, pulse and transmission output types are not standard.

#### ■ Measurement ranges

Select current and voltage measurement ranges as required from the value below to specify the values for the meter.

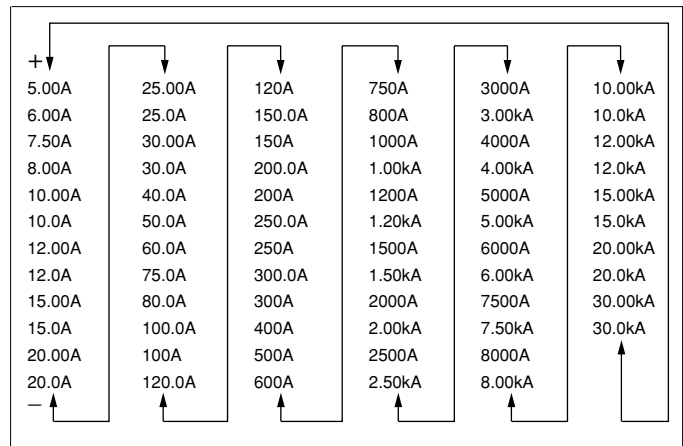
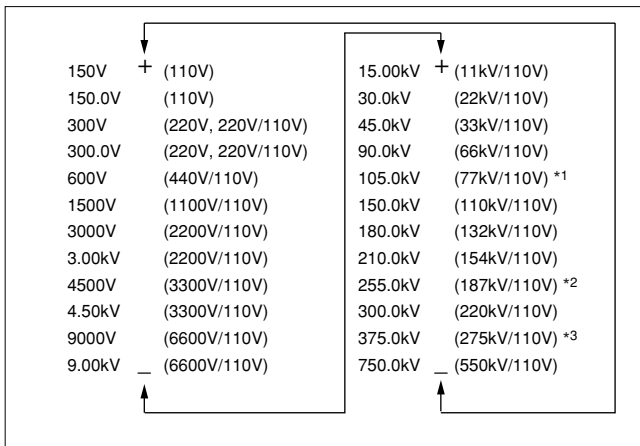

Notes: \*1 Full scale of the bar graph is 120.0kV.

\*2 Full scale of the bar graph is 270.0kV.

\*3 Full scale of the bar graph is 400.0kV.

## ■ Specifications

Accuracy of bar graph display	±5% (of displayed bar span)
Conforming standards	JIS C 1102 (IEC51), JIS C 1111, JIS C 1216, JIS C 1263
Display refresh time	Approx. 1s (approx. 0.25s for a bar graph)
Liquid crystal display	Main display Sub-display Bar graph
	Height: 11mm, 5 digits Height: 6mm, 4 digits (Left and right) 30 dots
Input power consumption	Voltage circuit: 0.25VA/110V max., 0.5VA/220V max., zero-phase voltage circuit: 0.5VA/190V max. Current circuit: 0.1VA max.
Overvoltage or overcurrent withstand	Voltage circuit: 2 × rated voltage for 10s, 1.2 × rated voltage continuously Current circuit: 40 × rated current for 1s, 20 × rated current for 4s, 10 × rated current for 16s, 1.2 × rated current continuously Control power supply: 1.5 × rated voltage for 10s, 1.2 × rated voltage continuously (100/110, 200/220V AC, 24/48V DC), 1.5 × rated voltage for 10s, 1.3 × rated voltage continuously (100/110V DC)
Insulation resistance	50MΩ (500V DC megger)
Dielectric strength	Except between analog output and pulse output circuits: 2000V AC, 50/60Hz, 1 minute Between analog output and pulse output circuits: 1500V AC, 50/60Hz, 1 minute
Impulse withstand	Between electrical circuits (excluding analog output) connected together and cabinet (ground): 6kV, 1.2/50μs Between analog output circuits and cabinet (ground): 5kV, 1.2/50μs
Noise immunity	(1) Oscillating surge voltage Damped oscillation noise wave of 1 to 1.5MHz, peak of 2.5 to 3kV: Measurement error < 10% (2) Rectangular impulse noise 1μs/100ns-wide rectangular-impulse 5 minutes: Measurement error < 10% Voltage and current circuits (normal mode/common mode): 1.5kV min. Power supply circuit (normal mode/common mode): 1.5kV min. Pulse output circuit (common mode): 1.0kV min. Relay output circuit (common mode): 1.0kV min. Control input circuit (common mode): 1.0kV min. Analog output circuit (induction noise): 1.0kV min. (3) Radio noise 150, 400, 900MHz, 5W radio noise 1m: Measurement error < 10% (4) Electrostatic noise (generated by capacitor discharging): 8kV Measurement error < 10%. No damage at 10kV-noise (not in operation)
Vibration and shock resistance	Vibration: 0.30mm double amplitude, 10 to 55Hz Shock: 490m/s <sup>2</sup> , three times in each ±X, ±Y, and ±Z directions
Cabinet	Material: ABS (V-0) resin Color: Black (Munsell color code: N1.5) Mass: 600g
Data backup time	10 years (set values and accumulated values)
Operating temperature and humidity	-10 to +55°C, 40 to 85% RH (no condensation)
Storage temperature	-25 to +70°C

## ■ Optional pulse output specifications

Output	kWh (electric energy) or kvar (reactive electric energy)					
Details	Output system: Optical MOS-FET relay, 1 NO contact Contact rating: 125V AC/DC, 70mA (both resistive and inductive loads)					
	Pulse width: 250ms ±10% (100 to 130ms for some measurement ranges) The unit of output pulse can be specified within the following ranges. The unit of output pulse remains unchanged even if the measurement range is switched. Full load power (kW, kvar) = $\sqrt{3} \times \text{rated voltage (V)} \times \text{rated current (A)} \times 10^{-3}$					
	Full load power (kW, kvar)	Pulse	Output	kWh	(kvarh)	Multiplication factor
	less than 10	1	0.1	0.01	0.001	0.1
	10 or more	10	1	0.1	0.01	1
	100 or more	100	10	1	0.1	10
	1,000 or more	1,000	100	10	1	100
	10,000 or more	10,000	1,000	100	10	1,000
	100,000 or more	100,000	10,000	1,000	100	10,000

# Switchboard Instruments

## Power line multi-meters

### WE12

#### ■ Type number nomenclature (Ordering code)

WE12 -       0

#### Basic type

#### Input circuit

- 1: Single-phase 2-wire
- 2: Single-phase 3-wire
- 3: 3-phase 3-wire
- 4: 3-phase 4-wire

#### Rated input voltage and current

- 1: 110V AC 5A, 110/ $\sqrt{3}$ V AC for 3-phase 4-wire
- 2: 110V AC 1A, 110/ $\sqrt{3}$ V AC for 3-phase 4-wire
- 3: 220V AC 5A, 220/ $\sqrt{3}$ V AC for 3-phase 4-wire
- 4: 220V AC 1A, 220/ $\sqrt{3}$ V AC for 3-phase 4-wire

#### Control power supply

- 1: 85 to 253V AC/80 to 143V DC common use
- 2: 20 to 56V DC

#### External operation input

- 0: No backlight, no external operation input
- 1: No backlight, display switch input
- A: Backlight, no external operation input
- B: Backlight, display switch input

#### Analog output

- 0: None (no analog, no transmission output)
- 1: 4 to 20mA DC
- 2: 0 to 1mA DC
- 3: 1 to 5V DC
- 4: 0 to 5V DC
- 5: 0 to 10V DC
- A: RS-485 (for transmission)

#### Note:

There are three analog output channels if the meter has no watt-hour pulse output, and two if the meter has one watt-hour pulse output.

#### ■ Ordering information

Specify the following:

- 1. Type number

#### Display pattern

Specify for all but standard pattern.

	Pattern	Main	Left	Right	Bar graph
None:	1(standard)	A(S)	V(RS)	W	A(S)
1:	2	W	V(RS)	A(S)	W
2:	3	Wh	V(RS)	A(S)	A(S)
3:	4	Wh	A(S)	W	A(S)
4:	5	Wh	A(S)	W	W
5:	6	A(S)	V(RS)	Hz	A(S)
6:	7	A(S)	V(RS)	–	A(S)
7:	8	V(RS)	V(ST)	V(TR)	V(RS)
8:	9	A(S)	A(R)	A(T)	A(S)
9:	A	V(RS)	–	Hz	V(RS)
A:	B	cos $\phi$	A(S)	W	W
B:	C	cos $\phi$	V(RS)	Hz	cos $\phi$
C:	D	cos $\phi$	–	Hz	cos $\phi$
D:	E	var	A(S)	W	W

#### Watt-hour pulse output

- 0: None
- 1: One output (NO contact)

#### ■ Wiring diagrams

##### Single-phase 2-wire system

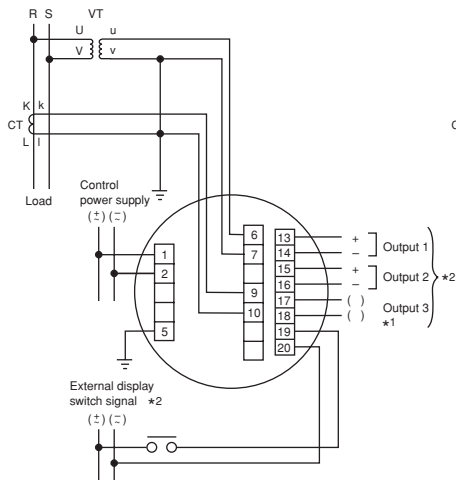

##### 3-phase 3-wire system, Single-phase 3-wire system \*3

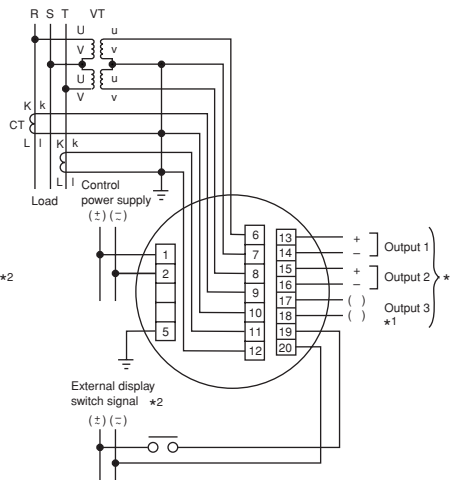

##### 3-phase 4-wire system

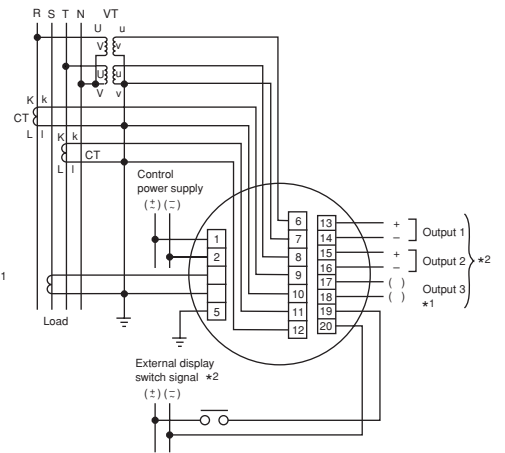

#### Terminal arrangement of meter with a communication output

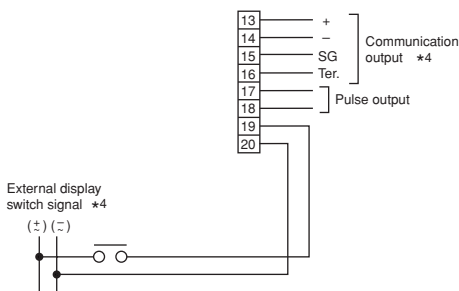

#### Notes:

- \*1 Output 1 and output 2 are for analog output only. Output 3 is for analog or pulse output. If output 3 is set for analog output, note the polarities: 17(+) and 18(-). Output pulses of electric energy (kWh) and reactive electric energy (kvar) are obtained at output 3.
- \*2 Output 1, output 2, output 3, and display switch signal input are optional.
- \*3 In the single-phase 3-wire system, line S (7) is a neutral line.
- \*4 The internal terminal resistor is connected by shorting terminals 14 and 16.

Be sure to connect voltage circuit wires (except for any meter used to measure current only).

#### ■ Dimensions, mm

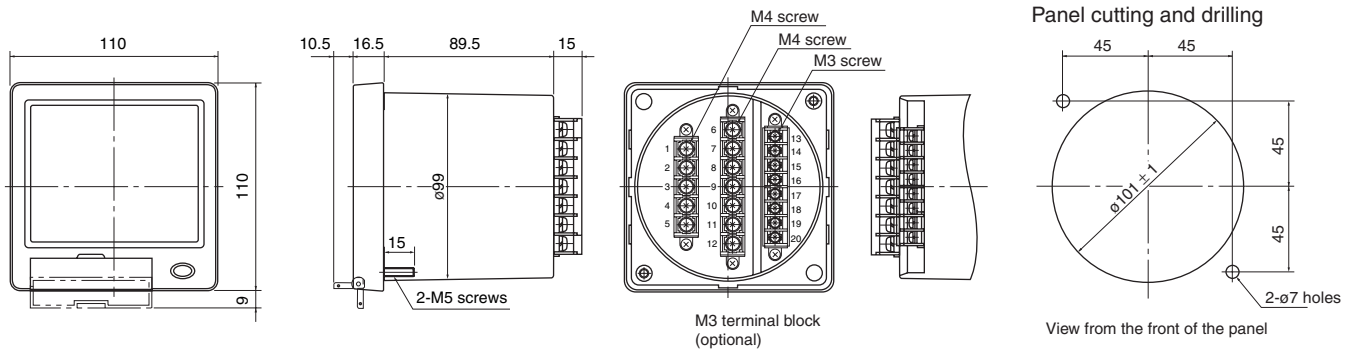

Mass: 600g