

**Air circuit breakers
DH series**

■ **Description**

The newly designed DH series air circuit breakers have excellent features as follows:

- The height and depth dimensions are identical in all sizes up to 3200AF
- Increased accessibility from the front enhances easy of installation, operation and maintenance
- No extra arc space required, This will assist in minimizing switchboard height and costs
- Very fast interruption by double break system
- Selective trip protective coordination functions



■ **Selection guide**

Series		DH series	
Frame size		800, 1250, 1600, 2000, 2500, 3200, 4000, 5000, 6300	
No. of poles		3, 4	
Installation	Fixed	Available (Up to 3200AF)	
	Draw-out	Available	
Closing mechanism		Manual spring, motor spring	
Tripping mechanism		Shunt trip, undervoltage trip	
Overcurrent protection device	Characteristics	L-characteristic	Available
		R-characteristic	Available
	Protection function *	Long time delay	Available
		Short time delay	
		Instantaneous	
		Pre-trip alarm	Available
		Ground fault	Available
		Preverse power	Available
		N-phase protection	Available
Contact temp.monitoring	Available		

* Availability of protective function differs depending on the OCR type.

■ **Comparison of breaking capacity**

Rated current (A)			800A	1250A	1600A	2000A	2500A	3200A	4000A	5000A	6300A	
Rated breaking capacity (kA. sym.)/ Rated making current (kA. peak)	Rated voltage 690V AC	DH□	50/105				65/143		75/165	85/187		
		DH□H	55/121									
		DH□P	85/187									
Rated voltage 440V AC	Rated voltage 440V AC	DH□	65/143				85/187		100/220	120/264		
		DH□H	80/176									
		DH□P	100/230									

■ **Standards (Conform to the following standards)**

- Conforming to
 - IEC60947-2
 - EN60947-2
 - AS3947-2
 - NEMA PUB No. SG3
 - ANSI C37.13
 - JIS C 8201-2-1
 - JEC 160

Air Circuit Breakers

DH series

Features

Standardized basic dimensions

The height and depth dimensions are identical in all sizes to 3200A. There are four common widths or frame size, from 800-2000A, from 2500-3200A, 4000A and 5000-6300A for the standard series. The panel cutout size is the same for all types of DH series ACB, which makes it easy to arrange the ACBs in switchboards.

Maximum power from minimum volume was central to the design specification. With a depth of 290mm for the fixed type and 345mm for draw-out, it is one of the smallest ACBs in the world.

ACBs with front connections are available off-the-shelf.

Front connections are especially suitable for smaller-depth switchboards.

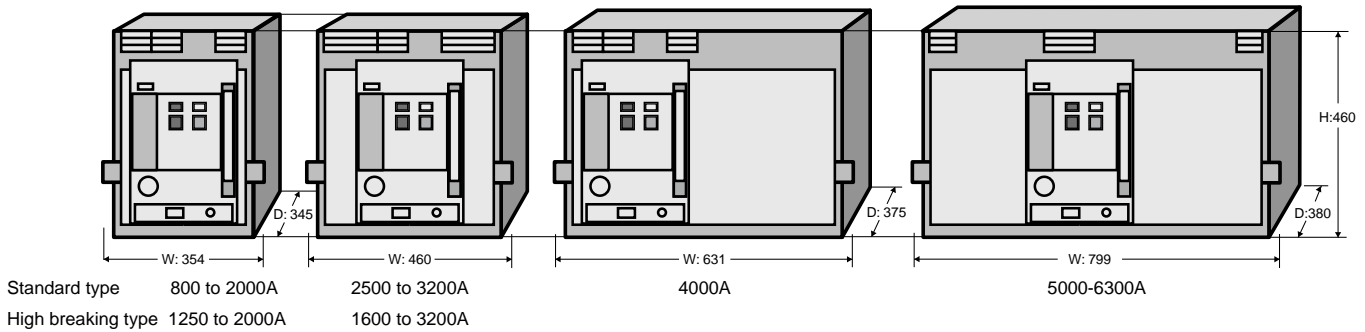

Geared toward the smallest depth in the world

Direct connection of the isolating main contacts to the hinges of the fixed main contacts eliminates the need for intermediate conductors. Allowing the DH series ACBs have the world's smallest depth resulting in space saving in switchboards.

More than twenty design patents have been registered for the DH series ACB.

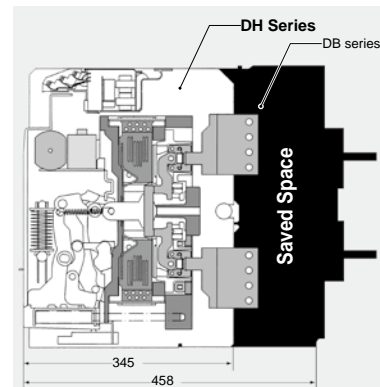

Increased accessibility from the front

It enhances ease of installation, operation, and maintenance. The double insulated design ensures that most accessories can be safely and easily installed by the user. Control, auxiliary and position switch terminals are mounted at the front on the ACB body for easy access. Due to the increased level of harmonics within the distribution network, the neutral phase is fully rated as standard.

No extra arc space required, vertical stacking permitted

The DH series ACB dissipates all arc energy within its unique "Double Break" arc chamber.

The internal energy dissipation within the ACB allows the clearance distance of the ACB to nearby earthed metal to be zero. This will assist in minimizing switchboard height and costs.

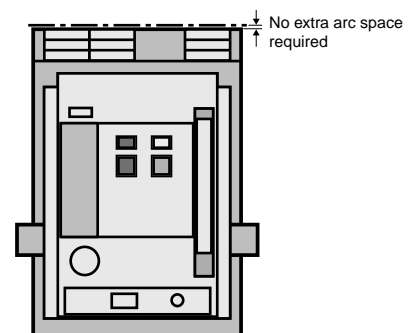
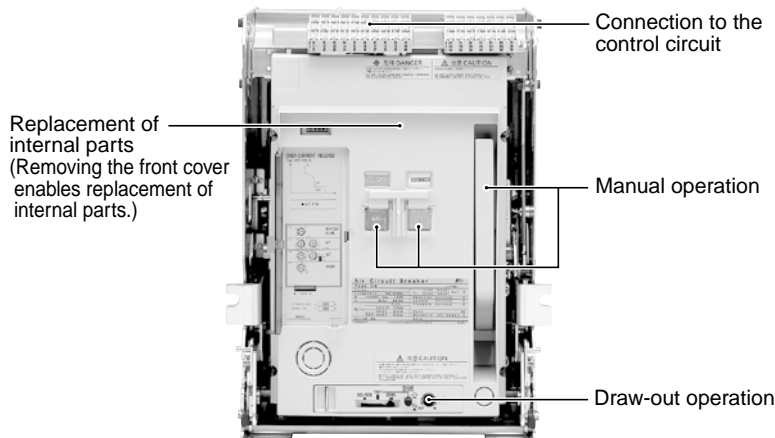

Very fast interruption by "Double Break" system

The unique "Double Break" main contact system ensures extremely fast interruption of short-circuit currents and substantially reduces main contact wear. The internally symmetrical "Double Break" structure allows reverse power connection.

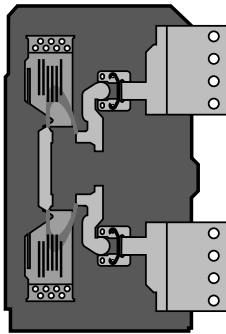

No clamp screws used for the main circuit contact units

There are no clamp screws or flexible leads in the main circuit contact units. This substantially enhances the durability of the main circuit contact units and improves the reliability in ON-OFF operation.

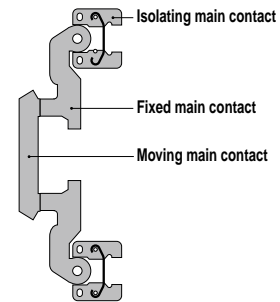

Enhanced selectivity

Fuji is so concerned about selectivity that all our protection relays have 'LSI' characteristics as standard.

This provides an adjustable time delay on overload (L) and also the I²t ramp characteristic (S).

As shown, these are essential to provide selectivity when grading with other protective devices such as downstream fuses and upstream relays.

The standard 'LSI' curve provides more than five million combinations of unique time current characteristics.

Zone selective interlocking is available to provide zero time delay selectivity.

As the rated breaking capacity is identical to the rated short-time withstand current full selectivity can be achieved.

Replacement of the main contacts

The fixed and moving main contacts can easily be replaced in the field, thus prolonging the life on the circuit breaker. Changing each pole takes around 15 minutes.

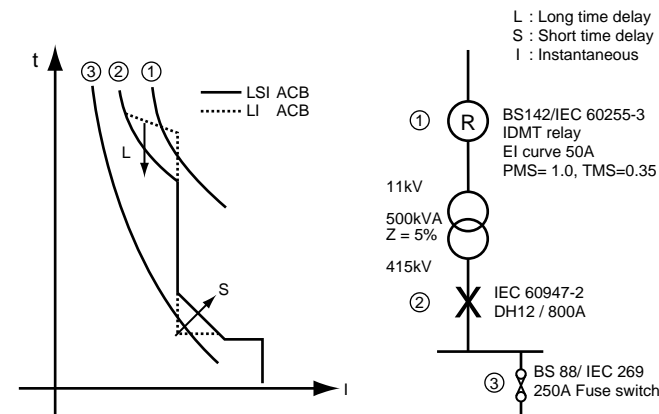
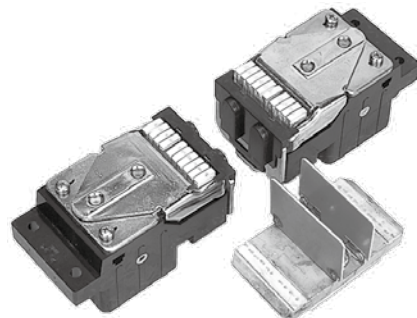

Type and rated current		DH08 800A	DH12H 1250A	DH25 2500A	DH16P 1600A	DH40 4000A	DH50 5000A
		DH12 1250A	DH16H 1600A	DH30 3200A	DH20P 2000A		DH60 6300A
		DH16 1600A	DH20H 2000A		DH25P 2500A		
		DH20 2000A			DH30P 3200A		
Performance	Rated breaking current (at 400V AC)	65kA	80kA	85kA	100kA	100kA	120kA
	Rated short-time withstand current (for 1 sec.)						

Note: If the ACB is DH-H type or DH-P type without INST trip/MCR function, the rated breaking capacity will decrease down to the rated latching current.

Air Circuit Breakers

DH series

Features

■ DH series provides positive protection for electric power systems.

DH series is equipped with an RMS sensing over-current release (OCR) having a wide range of protection functions and capabilities.

■ Optimum protective coordination

Why use a separate panel mounted protection relay when you can have all the benefits of I.D.M.T. protection integral to the ACB?

Fuji ACB is available with a choice of flexible protection curves to assist in selectivity applications.

All these curves are user definable and comply with IEC 60255-3. Standard transformer and generator protection characteristics are also available.

AGR-L Industrial & transformer protection
 AGR-R Characteristics to IEC 60255-3
 AGR-S Generator protection

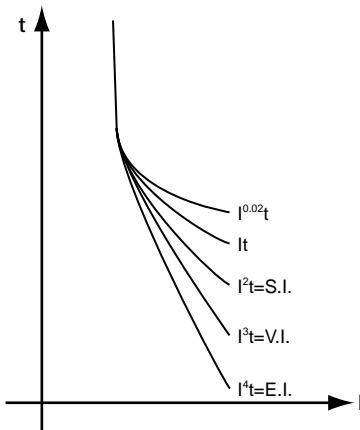

Inverse Definite Minimum Time (I.D.M.T.)
 (S.I. Standard Inverse)
 (V.I. Very Inverse)
 (E.I. Extremely Inverse)

■ Overload protection

Adjustable from 40-100% of rated current. True r.m.s detection up to the 19th harmonic, a distant vision for the competition who rarely see past the 7th. Neutral protection for all those Triple-N harmonics, such as 3rd, 9th and 15th. Also in case we forgot to mention, a "Thermal memory" as standard!

■ Two channel pre-trip alarm function (S-characteristic) *1

This function can be used to monitor and switch on additional power backup to feed critical circuits. For example, the function can be set so that when a pre-trip alarm is activated, an emergency generator starts to ensure a constant supply. This feature is only available on some AGR21 OCR models with a generator "S" characteristic.

■ N-phase protection function (optional)

In 3-phase, 4-wire systems that contain harmonic distortion, the 3rd harmonic may cause large currents to flow through the neutral conductor. The N-phase protection function prevents the neutral conductor from sustaining damage or burnout due to these large currents. Available in all OCRs except for generator "S" characteristic types.

■ Reverse power trip function (S-characteristic) *1 (The first-ever feature for ACBs)

This feature provides additional protection when paralleling generators. The AGR21 OCR for generator protection with the reverse power trip function, negates the need for installation and wiring in an external reverse power relay. This feature is available using an AGR21 OCR with a generator "S" type characteristic only.

■ Ground fault trip function

This function eliminates external relays to provide a ground fault protection to TN-C or TN-S power distribution systems on the load side. Ground fault protection on the line side is also available as an option.

■ Reverse phase protection function

This function detects the negative-phase current occurring due to reverse phase or phase loss and prevents burnout of a motor or damage to equipment.

■ Contact temperature monitoring function (optional) *2

This function monitors the temperature of the ACBs main contacts. An alarm indicates when the temperature exceeds 155C. Continuous monitoring of the contact temperature provides valuable input for preventative and predictive maintenance programs.

■ Advanced L.C.D display, Over Current Relay

The AGR-31B OCR comes standard with an LCD display. It can monitor and indicate phase currents, voltages, power, energy, power factor, frequency, and more. For features, refer to page 06/185.

*1: Available for type AGR-22BS, 31BS.

*2: Available for type AGR-22B, 31B OCR.

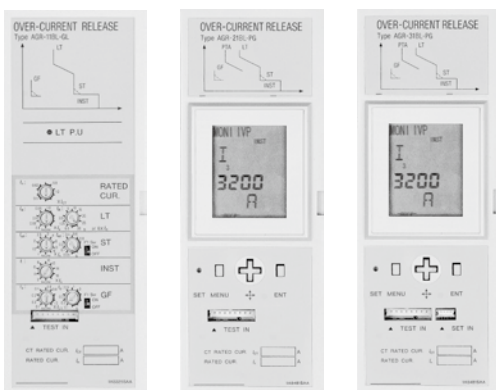

Standard OCR with adjustment dial Type AGR-11B

Standard OCR with LCD Type AGR-21B,22B

Enhanced OCR with LCD Type AGR-31B

■ Type number nomenclature

DH 08 3 H X - M 11BLAL F □

- ① **Basic type** —————
- ② **Frame size** —————
 - 08: 800A
 - 12: 1250A
 - 16: 1600A
 - 20: 2000A
 - 25: 2500A
 - 30: 3200A
 - 40: 4000A
 - 50: 5000A
 - 60: 6300A
- ③ **Number of poles** —————
 - 3: 3-pole
 - 4: 4-pole
- ④ **Breaking capacity class** —————
 - Blank: Standard
 - H: High
 - P: Super High
- ⑤ **Installation** —————
 - P: Fixed (Up to 3200A)
 - X: Draw-out with cradle
 - Q: Draw-out with cradle & shutter
- ⑥ **Closing mechanism** —————
 - T: Manual-spring
 - M: Motor-spring ex. M = 100V DC
- ⑦ **Overcurrent release device** —————
 - 11BLAL: Standard (LT, ST, INST/MCA)
 - 11BLGL: Std. Plus GF
 - (For details, see page 06/182.)
- ⑧ **Tripping device** —————
 - F: Shunt trip (AVR-1C) ex. F = 100V DC
 - R1: Undervoltage trip/Instantaneous (AUR-1CS)
 - R2: Undervoltage trip/500ms Time delay (AUR-1CD)
 - * If a capacitor extractor is used, the rated voltage of the voltage extractor is 48 V. Refer to page 06/177.

⑨ **Detailed specifications**

Specify any additional requirements, such as international standards compliance, special environmental usage, or accessories, when ordering. Also clearly indicate the applicable standards, main circuit voltage, and breaking current. See the tables below.
ex. IEC 440V AC 65kA

Applied standard		Special environment specification	
	Ordering code		Ordering code
IEC	IEC	Tropical uses	Tropical
EN	EN	Extremely cold use storage -40°C operating -25°C	Extremely cold
AS	AS	Anti-corrosion treatment	Anti-corrosion
NEMA	NEMA		
ANSI	ANSI		

Optional accessories		Ordering code
Auxiliary switch (4PDT)		Auxiliary switch (4PDT)
Auxiliary switch (10PDT)		Auxiliary switch (10PDT)
Auxiliary switch (7PDT) for general 4PDT, for low level circuits 3PDT		Auxiliary switch 4PDT + 3PDT
Auxiliary switch (10PDT) for general 7PDT, for low level circuits 3PDT		Auxiliary switch 7PDT + 3PDT
OFF (Open) padlock		OFF (Open) padlock
Automatic closing spring release device		Automatic closing spring release device
Capacitor trip device		AQR-1
Control circuit safety shutter		Control circuit safety shutter
Position switches		ALR-□P
Test jumper		Test jumper
Mis – insertion protection device		Mis – insertion protection device
Breaker fixing bolts		Breaker fixing bolts
Door interlock		Door interlock
Key lock		Key lock
Key interlock		Key interlock
Mechanical interlock		Mechanical interlock
Manual reset device		Manual reset device
IP55 cover		IP55 cover
Control circuit terminal cover		Control circuit terminal cover
Earthing device		Earthing device
Arc barrier		Arc barrier
Door flange		Door flange
Draw-out storage handle		Draw-out storage handle
Main circuit safety shutter		Main circuit safety shutter
Padlocking unit for main circuit safety shutter		Padlocking unit for main circuit safety shutter
Lifting plate		Lifting plate

External accessories		Ordering code
CT for neutral line 800 to 1600A frame		CW80-40LS
CT for neutral line 2000 to 4000A frame		EC160-40LS
Power transformer		TSE-30M
Lifter		AWR-1F (DH08 to DH30), AWR-2F (DH08 to DH40)
OCR checker		ANU-1

Air Circuit Breakers

DH series

Specifications, standard types

Frame size	800A		1250A		1600A		2000A		2500A		3200A		4000A		5000A		6300A																							
Basic type	DH08□■		DH12□■		DH16□■		DH20□■		DH25□■		DH30□■		DH40□■		DH50□■		DH60□■																							
No. of poles *3 *4	3	4	3	4	3	4	3	4	3	4	3	4	3	4	3	4	3	4																						
Rated current (A) *1 *2 (Max.)	IEC, EN, AS, JIS NEMA, ANSI		800 800		1250 1250		1600 1540		2000 2000		2500 2500		3200 3200		4000 3700		5000 -		6300 -																					
Rated current of the neutral pole (A)	800		1250		1600		2000		2500		3200		4000		5000		6300																							
Rated primary current of overcurrent tripping device (I _{CT}) (A) (For general feeder circuit use)	200 400 800		400 800 1250 1600		400 800 1250 1600 2000		400 800 1250		2500		3200		4000		5000		6300																							
Rated insulation voltage (U _i) (V, 50/60Hz) *5	1000																																							
Rated operational voltage (U _e)(V, 50/60Hz)*6	690																																							
Rated breaking capacity (kA, sym.)/ Rated making current (kA, peak) IEC, EN, AS, JIS [I _{cs} -I _{cu}] 690V AC *7	50/105 65/143 440V		65/143 65/143		65/143		65/143		65/143 85/187 85/187		75/165 -		85/187 -		100/220 120/264		-		-																					
NEMA, ANSI	600V AC 480V 240V		42/96.6 50/115 65/149.5		50/115 65/149.5		50/115 65/149.5 85/195.5		65/149.5 75/172.5 100/230		-		-		-		-		-																					
Installation																																								
Fixed type P	●		●		●		●		●		●		-		-		-																							
Draw-out type with cradle X	●		●		●		●		●		●		●		●		●																							
Draw-out type with cradle and shutter Q	●		●		●		●		●		●		●		●		●																							
Main circuit terminal connection																																								
Fixed type	Vertical terminal		▲		▲		▲		○		○		○		-		-		-																					
	Horizontal terminal		○		○		○		▲		▲		▲		-		-		-																					
	Front terminal		▲		▲		▲		▲		▲		▲		-		-		-																					
Draw-out type	Vertical terminal		▲		▲		▲		○		○		○		○		○		○																					
	Horizontal terminal		○		○		○		▲		▲		▲		-		-		-																					
	Front terminal		▲		▲		▲		▲		▲		▲		-		-		-																					
Rated impulse withstand voltage (U _{imp}) (kV)	12																																							
Rated short time withstand current (I _{sw}) (kA, rms)	1 sec.		65		65		65		85		85		100		120		120																							
	3 sec.		50		50		50		65		65		85		85		85																							
Rated latching current (kA, rms)	65		65		65		65		85		85		100		120		120																							
Total fault clearing time (s)	0.03														0.05																									
Closing time (s) max.	10																																							
Spring charging time Closing time	0.08																																							
Dimensions(mm)																																								
Fixed type			a		360		445		360		445		360		445		466		586		466		586		-		-		-		-		-							
			b		460		460		460		460		460		460		460		460		460		460		-		-		-		-									
			c		290		290		290		290		290		290		290		290		290		290		-		-		-		-									
			d		75		75		75		75		75		75		75		75		75		75		-		-		-		-									
Draw-out type			a		354		439		354		439		354		439		345		439		460		580		460		580		631		801		799		1034		799		1034	
			b		460		460		460		460		460		460		460		460		460		460		460		460		460		460		460		460					
			c		345		345		345		345		345		345		345		345		345		345		345		375		380		380		380		380					
			d		40		40		40		40		40		40		40		40		40		40		40		53		60		60		60							
Mass (kg) For draw-out type X	73		86		73		86		76		90		79		94		105		125		105		125		139		176		200		260		220		285					

Notes: ● Available - Not available

□ Replace the □ mark in the type number by the pole number code

3-pole: 3 4-pole: 4

■ Replace the ■ mark in the type number by the installation code

Fixed: P Draw-out with cradle: X Draw-out with cradle and shutter: Q

○ Standard ▲ Available on request

*1 At ambient temperature of 40°C.

*2 Rated current at standard terminal connection. See page 06/202 for other terminal connection.

*3 The 2-pole ACBs are similar to 3-pole types except that the center pole contacts and conductors are omitted.

*4 If there is no phase-N protections, an IT system cannot be used for a 4-pole breaker.

*5 1000V AC applies to IEC60947-2 and JIS C8201-2-1.

*6 690V AC applies to IEC60947-2 and JIS C8201-2-1.

*7 Cannot be used for an IT distribution system.

■ Specifications, high breaking types

Frame size	1250A		1600A		2000A		1600A		2000A		2500A		3200A			
Basic type	DH12 □H■		DH16 □H■		DH20 □H■		DH16 □P■		DH20 □P■		DH25 □P■		DH30 □P■			
No. of poles *3	3	4	3	4	3	4	3	4	3	4	3	4	3	4		
Rated current (A) *1 *2 (Max.)	IEC, EN, AS		1250		1600		2000		1600		2000		2500		3200	
	NEMA, ANSI		1250		1600		2000		1600		2000		2500		3200	
	JIS		1250		1600		2000		1600		2000		2500		3200	
Rated current of the neutral pole (A)	1250		1600		2000		1600		2000		2500		3200			
Rated primary current of overcurrent tripping device (I _{CT}) (A) (For general feeder circuit use)	200		1600		2000		200		2000		2500		3200			
	400						400									
	800						800									
	1250						1250									
Rated insulation voltage (U _i) (V, 50/60Hz) *4	1000															
Rated operational voltage (U _e)(V, 50/60Hz)*5	690															
Rated breaking capacity (kA, sym.)/ Rated making current (kA, peak)																
IEC, EN, AS, JIS [I _{CS} =I _{CU}] 690V AC	50/121						85/187									
440V	80/176						100/220									
NEMA, ANSI 600V AC	42/96.6						50/115									
480V	65/149.5						80/184									
240V	80/184						100/230									
Installation																
	Draw-out type with cradle X	●		●		●		●		●		●		●		
Draw-out type with cradle and shutter Q	●		●		●		●		●		●		●			
Main circuit terminal connection																
	Draw-out type	Vertical terminal		○		○		○		○		○		○		
		Horizontal terminal		▲		▲		▲		▲		▲		▲		
		Front terminal		-		-		-		-		-		-		
Rated impulse withstand voltage (U _{imp}) (kV)	12															
Rated short time withstand current (I _{CS}) (kA, rms)	1 sec.		80		100		100		100		100		100			
	3 sec.		55		75		75		75		75		75			
Rated latching current (kA, rms)	65						85									
Total fault clearing time (s)	0.03															
Closing time (s) max.	10															
	Spring charging time Closing time	0.08														
Dimensions(mm)																
	Draw-out type	a	354	439	354	439	354	439	460	580	460	580	631	801	460	580
		b	460		460		460		460		460		460		460	
		c	345		345		345		345		345		345		345	
		d	40		40		40		40		40		40		40	
Mass (kg) For draw-out type X	79	94	79	94	79	94	105	125	105	125	105	125	105	125		

Notes: ● Available - Not available

□ Replace the □ mark in the type number by the pole number code

3-pole: 3 4-pole: 4

■ Replace the ■ mark in the type number by the installation code

Draw-out with cradle: X Draw-out with cradle and shutter: Q

○ Standard ▲ Available on request

*1 At ambient temperature of 40°C.

*2 Rated current at standard terminal connection. See page 06/202 for other terminal connection.

*3 The 2-pole ACBs are similar to 3-pole types except that the center pole contacts and conductors are omitted.

*4 1000V AC applies to IEC60947-2 and JIS C8201-2-1.

*5 690V AC applies to IEC60947-2 and JIS C8201-2-1.

• If the ACB is DH-H type or DH-P type without INST trip/MCR function, the rated breaking capacity will decrease down to the rated latching current.

Air Circuit Breakers DH series

■ Appearance

(Example of draw-out type equipped with full accessories)

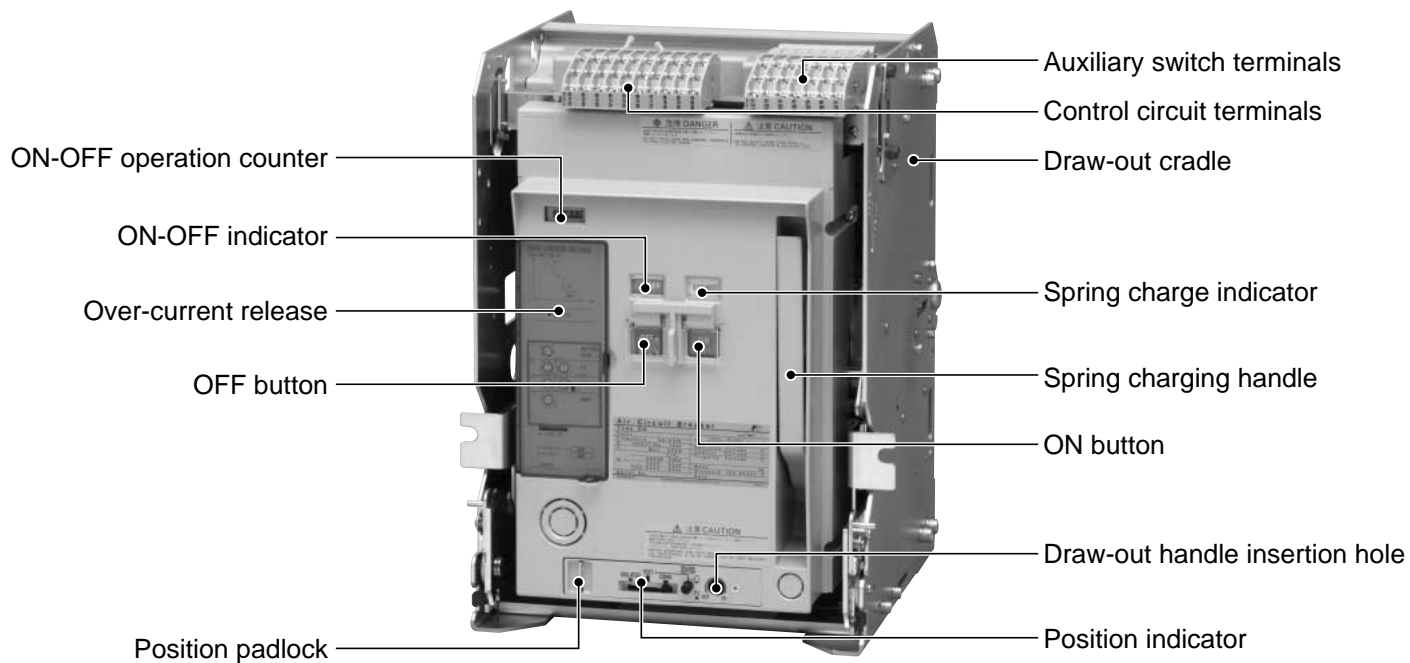

■ Internal construction

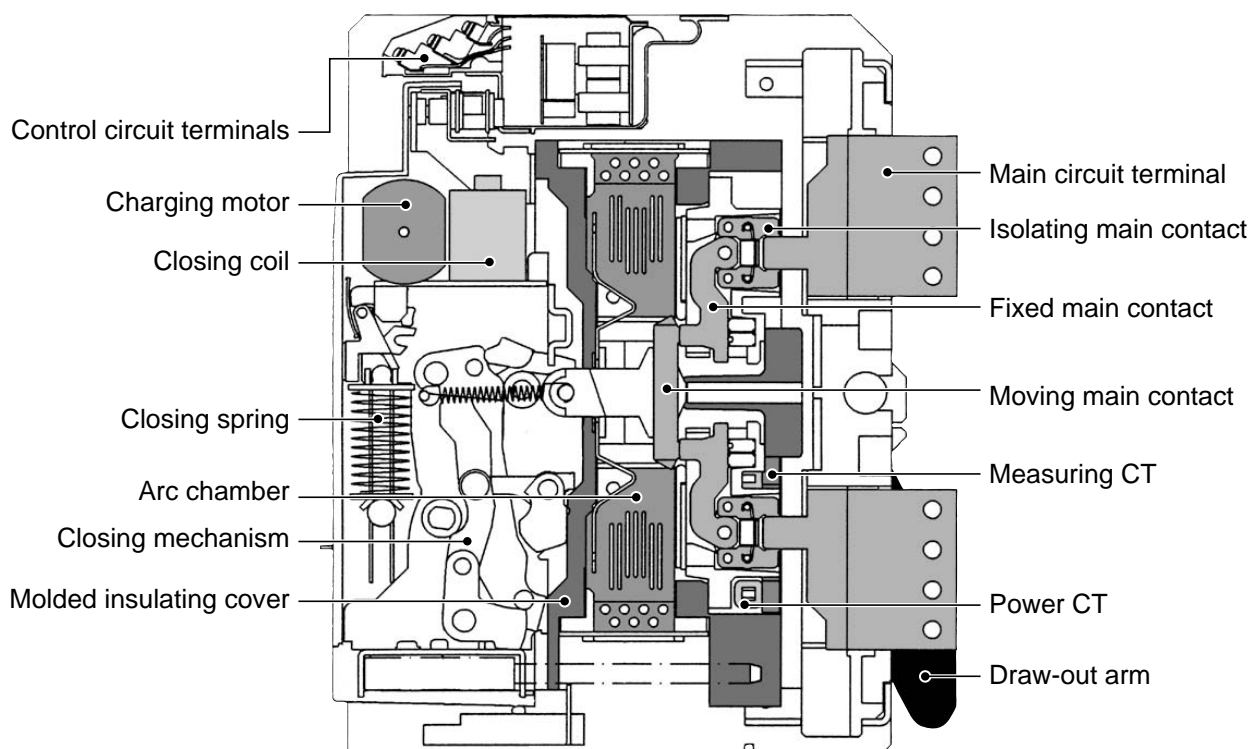

■ Mounting

● Draw-out type

This type of ACB consists of a breaker body and a draw-out cradle. The breaker body can be moved within or removed from the draw-out cradle that is fixed in the switchboard. There are four breaker body positions: CONNECTED, TEST, ISOLATED, and DRAW-OUT. The switchboard panel door can be kept closed in the CONNECTED, TEST, and ISOLATED positions (“shut-in three positions”).

Note: On the position counter, an abbreviated form CONN is used instead of CONNECTED.

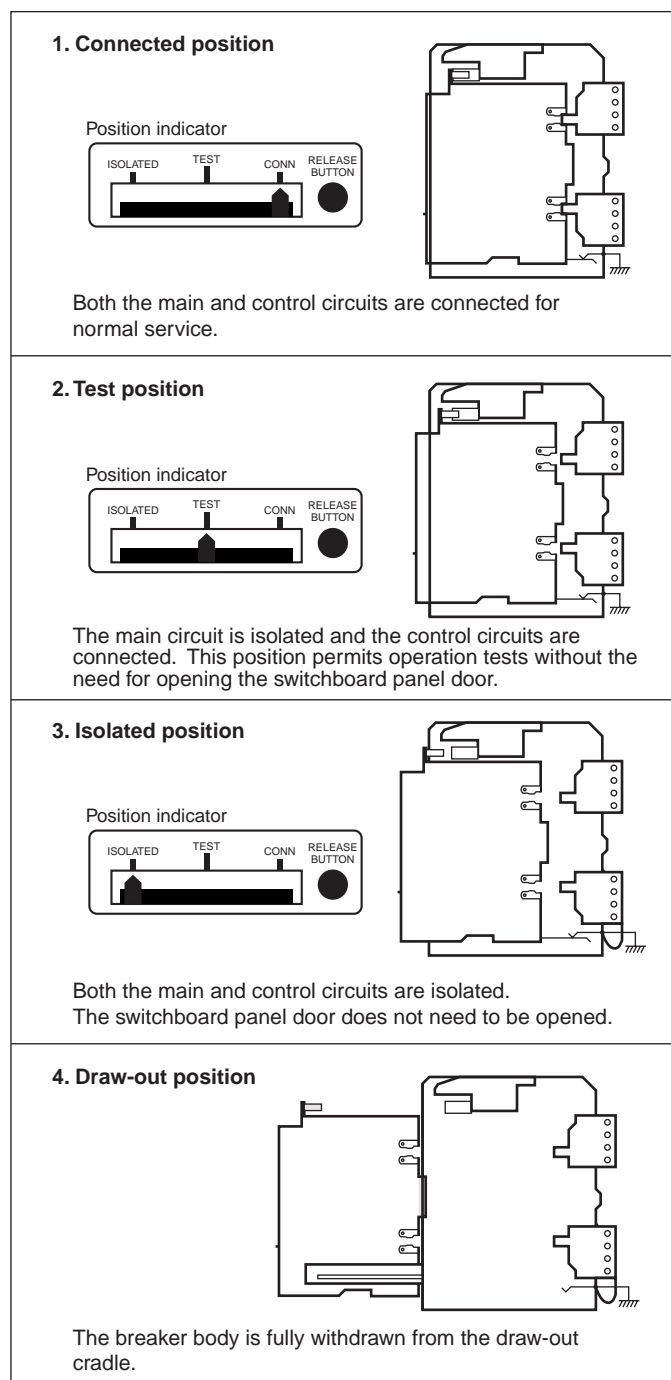

● Fixed type (standard series only)

This type of ACB has no draw-out cradle and is designed to be directly mounted in the switchboard.

■ Connection methods

● Main circuit terminals

Three(3) types of main circuit terminal arrangements are available: vertical terminals, horizontal terminals, and front connections. Different types of terminal arrangements can be specified for the line and load sides. Unless otherwise specified by the user, horizontal terminals are given to types DH08, DH12 and DH16 ACBs on both the line and load sides, and vertical terminals to DH20, DH25, DH30 and DH40. For DH40, only vertical terminals available. For High breaking series (H, P type), vertical terminals are standard and horizontal terminals are optional, and front connections are not available.

The breaker applicable maximum rated current derated depending on the connection method.

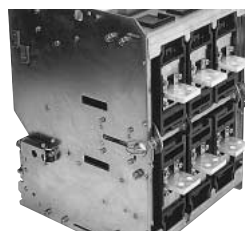

Horizontal terminals



Vertical terminals

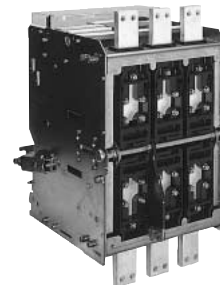

Front terminals

● Control circuit terminals

Control circuit terminals are front located to allow easy wiring/access.

- The terminal blocks (for auxiliary switches, position switches, and control circuits) are positioned on the top of the ACB front panel and can be accessed from the front for wiring.

- M4 screw terminals are available.



Screw terminals

Air Circuit Breakers

DH series

■ Closing method

With DH series ACB, there are two kinds of closing methods; manual charging type and motor charging type.

● Manual charging type

With manual charging type DH series ACB, the closing springs are charged manually by means of the spring charging handle. The ON/OFF operation of ACB is performed by ON/OFF buttons on the ACB.

● Charging the closing springs

The closing springs are charged manually by pumping the spring charging handle.

● Closing the ACB

Pressing the ON button on the ACB closes the ACB.

● Opening the ACB

Pressing the OFF button on the ACB opens the ACB. The ACB cannot be closed as long as the OFF button is pressed.

● Motor charging type

With motor charging type DH series ACB, the closing springs are charged by a motor. The ON/OFF operation of ACB is performed remotely. The DH series ACB is also equipped with a manual charging mechanism to facilitate inspection.

● Operation power supply

Rated voltage (V)	Applicable voltage range (V)		Operation power supply ratings		
	CHARGE/ ON operation	OFF operation *1	Motor inrush current (peak) (A)	Motor steady-state current (A)	Closing command current (peak) (A)
100 AC	85-110		7	1.1	0.48
110 AC	94-121		7	1.1	0.39
120 AC	102-132		7	1.1	0.37
200 AC	170-220		4	0.7	0.24
220 AC	187-242		4	0.7	0.19
240 AC	204-264		4	0.7	0.18
24 DC	18-26		14	4	1.65
48 DC	36-53		10	1.6	0.86
100 DC	75-110		6	0.8	0.39
110 DC	82-121		6	0.8	0.37
125 DC	93-138		6	0.8	0.31
200 DC	150-220		4	0.5	0.19
220 DC	165-242		4	0.5	0.18

Note: *1 For the ratings of the shunt trip device, see page 06/177.

and maintenance work. The electronized control circuit promises optimum control to the charging of the closing spring and ACB ON/OFF operation.

● Charging the closing springs

The closing springs are automatically charged by a motor. When the closing springs are released with the ACB turned on, they are automatically charged again by the motor in preparation for the next ON operation.

● Closing the ACB

Turn on the remote ON switch to close the ACB. As the anti-pumping mechanism is equipped, even if the ON switch is turned on continuously, the ACB's closing operation is performed only once. When the ACB has to be closed again, turn off the ON switch to reset the anti-pumping mechanism, turn on the ON switch after the closing springs charge completed. If the ON and OFF signals are simultaneously given to the ACB, the ON signals are ignored.

● Opening the ACB

To open the ACB remotely, use the shunt trip device (see page 06/177), or the undervoltage trip device (see page 06/178).

● Step-down transformer (separately installed)

The maximum rated voltage applicable to the operation power supply is 240V AC. If higher voltage has to be applied, a step-down transformer is needed.

The following step-down transformers are available as options.

Rated control voltage	Transformer		
	Type	Capacity	Voltage ratio
410-470V AC	TSE-30M	300VA	450/220V
350-395V AC	TSE-30M	300VA	380/220V

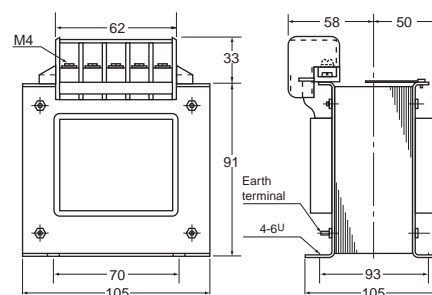

■ Tripping devices

• Continuous rating shunt trip device

The continuous-rating shunt trip device allows the ACB to be opened when an external protection relay against overcurrent or reverse power is activated.

Because of its continuous rating, the device can also be used to provide an electrical interlock to the ACB.

When an AGR-11 OCR is fitted or no OCR is fitted, continuous rating shunt trip and undervoltage trip can not be fitted to the same ACB.

• Capacitor trip device

In using with the continuous rating shunt trip device, the capacitor trip device can be used to trip the ACB within a limited period of 30 sec if large voltage drop occurs due to an power (AC) failure or short-circuit.

The rated voltage of the voltage extractor must be 48 V DC. When the continuous rating shunt trip device is used with capacitor trip device, "NO" contact of auxiliary switch of ACB should be connected in series, otherwise, the internal damage may occur.

Operation check using test jumper is not allowed.

Shunt trip rating (Continuous rating type)

Type	Rated voltage (V)	Operational voltage (V)	Peak excitation current (A)	Normal current (A)	Opening time (max.) (ms)
	100 AC	70–110 AC	0.48	0.32	
	110 AC	77–121 AC	0.39	0.26	
	120 AC	84–132 AC	0.37	0.24	
	200 AC	140–220 AC	0.24	0.16	
	220 AC	154–242 AC	0.19	0.13	
	240 AC	168–264 AC	0.18	0.12	
AVR-1C	24 DC	16.8–26.4 DC	1.65	1.1	40
	48 DC	33.6–52.8 DC	0.86	0.57	
	100 DC	70–110 DC	0.39	0.26	
	110 DC	77–121 DC	0.37	0.25	
	125 DC	87.5–137.5 DC	0.31	0.21	
	200 DC	140–220 DC	0.19	0.13	
	220 DC	154–242 DC	0.18	0.12	

Capacitor trip rating

Type	AQR-1
Rated voltage	100-120V AC
Operational voltage range	70 to 110% of rated voltage
Rated frequency	50/60Hz
Rated voltage of shunt trip used	48V DC
Power consumption	100VA

Control circuit

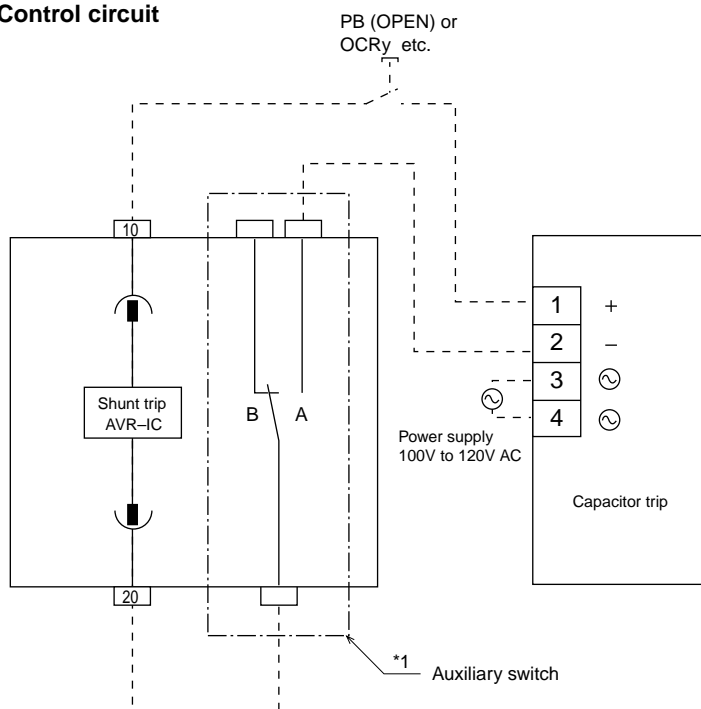

----- User Wiring

*1: Use auxiliary switch for capacitor trip

Dimensions, mm

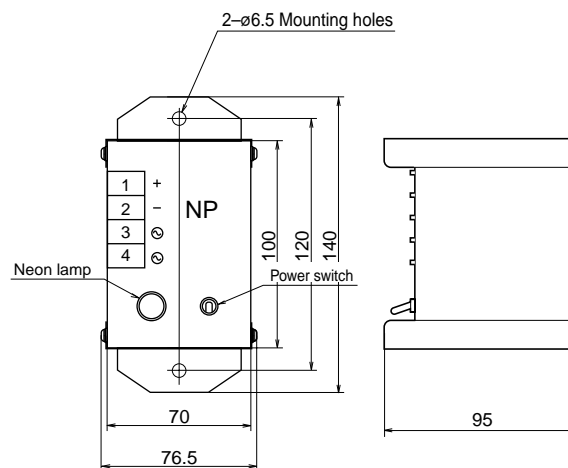

Air Circuit Breakers

DH series

• Undervoltage trip device (UVT)

The undervoltage trip device (UVT) trips the ACB when the control voltage drops below the opening voltage. When the control voltage is restored to the pick-up voltage, the ACB can be closed. The pick-up voltage is fixed to 85% of the rated voltage.

The UVT consists of a tripping mechanism and an undervoltage trip control device. The trip control device is available in two types: AUR-ICS and AUR-ICD.

Type AUR-ICS provides an instantaneous trip to the ACB when the control voltage drops below the opening voltage. Type AUR-ICD provides a delayed trip to the ACB when the control voltage remains below the opening voltage for at least 500 ms.

Adding a pushbutton switch (with normally opened contacts) between terminals 24 and 30 allows the ACB to be tripped remotely.

The undervoltage trip device is builtin the ACB unit.

AC undervoltage trip control circuit

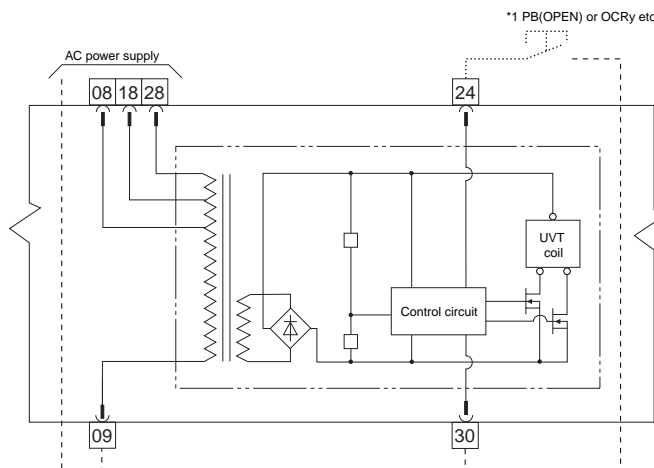

*1 Tripping signal is 48 VDC/5 mA.
Apply tripping signal for at least 80 ms.

Undervoltage trip Ratings

Type of UVT Control Device	Rated Voltage 50/60Hz (V)	Opening Voltage (V)	Pick-up Voltage (V)	Coil Excitation Current (A)	Power Consumption (VA)	
					Normal	Reset
AUR-1CS	100 AC	35 – 70	85			
AUR-1CD	110 AC	38.5 – 77	93.5			
	120 AC	42 – 84	102			
	200 AC	70 – 140	170			
	220 AC	77 – 154	187			
	240 AC	84 – 168	204	0.1	8	10
	380 AC	133 – 266	323			
	415 AC	145 – 290	352			
	440 AC	154 – 308	374			
	24 DC *	8.4 – 16.8	20.4			
	48 DC *	16.8 – 33.6	40.8			
	100 DC *	35 – 70	85			

*Available soon. Contact Fuji for the details.

■ **Overcurrent trip device (OCR)**

The AGR series of overcurrent trip device (OCR) featuring high reliability and multiple protection capabilities is available for DH series. Controlled by an internal 8-bit microprocessor, the OCR provides reliable protection against overcurrent. The OCR range is divided into three groups: L-characteristic, R-characteristic (both for general feeder) and S-characteristic (for generator protection).

Each group consists of:

- Type AGR-11B : Standard OCR with adjustment dial
- Type AGR-21B, 22B : Standard OCR with L.C.D.
- Type AGR-31B : Enhanced OCR with backlit L.C.D.

Optional protection functions of the OCR include those against ground fault, earth leakage, undervoltage and reverse power. Pre-trip alarm function can also be installed.

• **Types of tripping functions**

1. Adjustable long time-delay trip function (LT)

Effective value (RMS) detection used to accurately read through distorted waveforms.

In addition to the standard L and S-characteristics, the R-characteristic is available in five types for long time-delay trip. The R-characteristic can be used to give selective tripping coordination with e.g., fuses. (See page 06/170.)

Hot-start mode (applicable to L-characteristic of AGR-21B, 31B)

In the hot-start mode, when overcurrent occurs in a load state, the circuit breaker operates in a shorter amount of time as compared with operation in the cold-start mode. The hot-start mode is suitable to protect motors and wires from thermal damage. The cold-start is set at factory default.

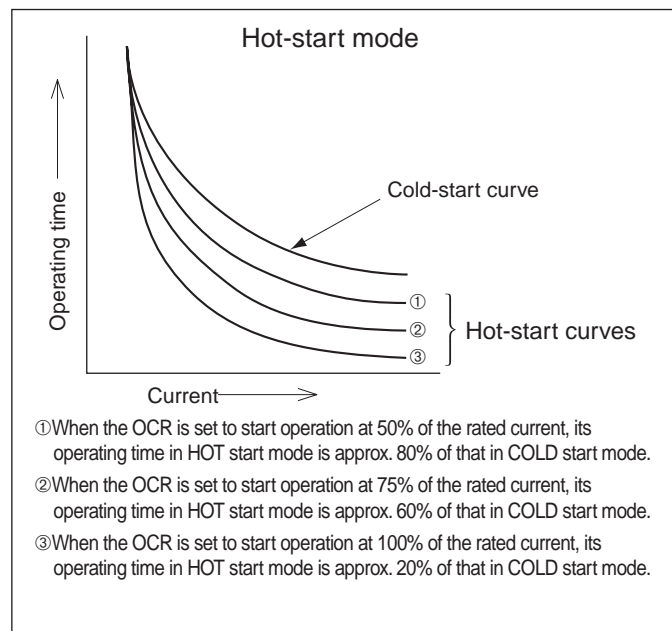

2. Adjustable short time-delay trip function (ST)

Ramp characteristic has been provided in addition to definite time-delay trip characteristic. The ramp characteristic gives coordinative protection with downstream circuit breakers or fuses properly. In type AGR-L and AGR-R OCRs, the definite time characteristic is activated when the load current is 1000% or more of the rated current [In] (500% or more of the rated current [In] for AGR-S). The definite time-delay trip characteristic and ramp characteristic are selectable with a switch. The ST trip function is set to the definite time-delay trip characteristic at factory shipment.

Ramp characteristic curve
(L or R-characteristic)

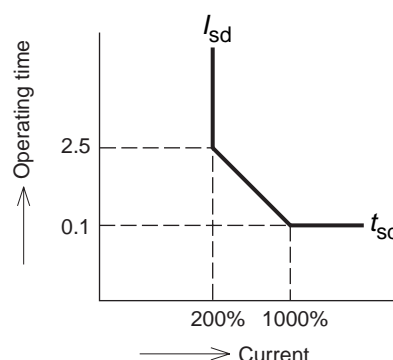

3. Adjustable instantaneous trip function (INST/MCR)

The INST trip function trips the ACB when the short circuit current exceeds the pickup current setting, irrespective of the state of the ACB.

The making current release (MCR) trips the ACB when the short circuit current exceeds the pickup current setting during closing operation. After the ACB is closed, the MCR is locked and kept inoperative.

The INST and MCR are switch-selectable for AGR-21B, 22B and 31B. (AGR-11B is INST only, MCR is not selectable.)

Note) The MCR needs the control power. If the control power is lost, the MCR provides the INST trip function only.

4. Adjustable pre-trip alarm (PTA)

The pre-trip alarm function provides an alarm signal via the alarm contact (1NO-contact) when the load current exceeding a predetermined value lasts for a predetermined time. A 2-channel pre-trip alarm function is available for S-characteristic. This function can be used to adjust feeding to loads according to their priority.

The pre-trip alarm is automatically reset when the load current drops to the predetermined value.

Note that this function needs the control power.

Air Circuit Breakers

DH series

5. Ground fault trip function (GF)

The peak value sensing is used (the residual current of each phase is detected).
The GF pickup current can be set between 10% and 100% of the CT rated primary current [I_{CT}].

<Ramp characteristic is added>

The ramp and definite time characteristics are switch selectable. The GF trip function comes into operation with the definite time characteristic when the load current reaches 100% or more of the CT rated primary current [I_{CT}]. The GF trip function is factory set to the definite time characteristic.

When using a 3-pole ACB in a 3-phase, 4-wire system, be sure to use an optional CT for neutral line. (See page 06/196.)

Note 1: The GF trip function comes usually with operation indications (LED and contact output). If you need nothing but ground fault indication without a ground fault tripping operation, specify at the time of ordering.

Note 2: Restricted and unrestricted ground fault protection REF is available as option. This enables to protect against ground fault on the line side of ACB.

6. Reverse power trip function (RPT)

(For AGR-22B and AGR-31B only)

The RPT function protects 3-phase generators running in parallel against reverse power. The RPT pickup current can be set in seven levels: 4% through 10% of the generator rated power.

If the rated main circuit voltage exceeds 250 VAC, a step-down power transformer is needed. When ordering the ACB, state the step-down ratio of the transformer you will use.

7. N-phase protection function (NP)

This NP function is available on 4-pole ACBs and prevents the neutral conductor from suffering damage or burnout due to overcurrent.

The NP trip pickup current can be set between 40% and 100% of the OCR rated primary current for L and R-characteristics or of the generator rated current for S-characteristic.

It is factory set to a value specified at the time of ordering.

Note 1: The NP trip function comes usually with operation indications (LED and contact output). The NP trip pickup current setting is shared by the LT trip function.

Note 2: The HOT start mode is available for AGR-21B and AGR-31B. The operating time for the NP trip function is linked to that for the LT trip function.

8. Undervoltage alarm function (UV)

(For AGR-22B and AGR-31B only)

This function monitors the main circuit voltage, and gives an alarm on the LCD and an output signal via an alarm contacts when the voltage drops below the setting voltage.

The alarm is activated when the main circuit voltage drops below the setting voltage (selectable from 40%, 60% or 80% of the rated main circuit voltage [V_n]), and is deactivated when the main circuit voltage rises to the recovery setting voltage (selectable from 80%, 85%, 90% or 95% of the rated main circuit voltage [V_n]).

If the rated main circuit voltage exceeds 250 VAC, a step-down power transformer is needed. When ordering the ACB, state the step-down ratio of the transformer you will use.

Note 1: The undervoltage alarm function is disabled unless the main circuit voltage has once risen to the recovery setting voltage or higher.

Note 2: If the undervoltage alarm function is used in conjunction with the undervoltage trip device (see page 06/178), an alarm may occur after the ACB trips open depending on the alarm setting voltage.

9. Contact temperature monitoring function (OH)

(For AGR-31B only.)

The HEAT function prevents the ACB from suffering damage due to overheat.

It monitors the temperature of the ACB main contacts, and gives an alarm on the LCD and an output signal via the alarm contact (1NO-contact) when the temperature exceeds 155°C. The alarm can be manually reset when the temperature drops to a normal temperature.

If you want to set the threshold temperature to a lower value, contact Fuji.

This function needs the control power.

Note 1: "Alarm" or "Trip" can be selected.

10. Reverse phase protection function (NS)

(For AGR-21B and AGR-31B only)

This function detects the negative-phase current occurring due to reverse phase or phase loss and prevents burnout of a motor or damage to equipment. The protection setpoint ranges from 20% to 100% of the main circuit rated current [I_n].

11. Zone interlock (Z)

(For AGR-22B and AGR-31B only)

The zone-selective interlock capability permits tripping of the ACB upstream of and nearest to a fault point in the shortest operating time, irrespective of the short time delay trip time setting, and minimizes thermal and mechanical damage to the power distribution line.

• NON setting and fail-safe feature

1. NON setting

Setting a trip pickup current setting dial to the NON position allows you to render the corresponding protection function inoperative.

Dials having the NON position include LT, ST, INST/MCR, and GF.

Appropriate NON setting will be a useful means for optimum selectivity.

2. Fail-safe feature

The OCR has a fail-safe mechanism in case setting dials are improperly set to the NON position.

- If the ST and INST trip pickup current setting dials are both set to NON, the fail-safe mechanism will activate the INST trip function to trip the ACB when a fault current equal to or more than 16 times the rated current [I_n] flows through the ACB.
- If the ST and MCR trip pickup current setting dials are both set to NON, the fail safe mechanism will activate the ST delay trip function to trip the ACB when a fault current equal to or more than 10 times (5 times for generator protection) the rated current [I_n] flows through the ACB.

• Field test or facility

Type AGR-21B/22B/31B OCRs are equipped with a field test function to verify the long time delay, short time delay, instantaneous and ground fault trip features without the need for tripping of the ACB.

To check type AGR-11B, use the type ANU-1 OCR checker (optional).

● **Operation indication function**

1. Indication via single contact (AGR-11B)

When the LT, ST, INST/MCR, or GF trip function is activated, an output is generated via 1NO-contact.

The 1NO-contact will turn off after 40ms or more.

A self-hold circuit is needed.

2. Indication via individual contacts (AGR-21B, 22B, 31B)

When the LT trip, ST trip, INST/MCR trip, GF trip, RPT, NS, REF, UVT, pre-trip alarm, or contact temperature monitoring function is activated, LCD will indicate their operation individually and output is generated via the corresponding contact.

The OCR also has a self-diagnostic feature that monitors the internal tripping circuits. If detecting any fault in the circuits, this feature turns on the system alarm indicator. The control power is needed.

Operation indications

○: Self-hold (Note 1)

×: Auto-reset

△: status indication

—: Not applicable

Protective characteristic Function	L/R-characteristic	
	LCD	Contact
LTENP	○	○
ST	○	○ (Note 4)
INST/MCR	○	
GF (Ground fault)	○	○
OH (Contact temperature monitoring)	○	○
(Note 2) NS (Reverse phase)	○	○
REF (Line side GF)	○	○
Trip indication *1	△	△
RPT (Reverse power trip)	—	—
PTA (Pretrip alarm)	×	×
PTA2 (Pretrip alarm)	×	×
(Note 3) UV (Undervoltage alarm)	○	△
Spring charge indication	△	△
System alarm	○	○

Note 1: To reset the operation indication, press the button on the OCR.

Note 2: Only one function can be selected from OH, NS, REF or trip indication. Selection of two or more functions involves manual connection of their control circuits (custom configuration). Contact Fuji for details.

Note 3: Only one function can be selected from PTA2, UV or spring charge indication. Selection of two or more functions involves manual connection of their control circuits (custom configuration). Contact Fuji for details.

Note 4: Motion indication contacts are commonly used for ST and INST/MCR.

*1: A switch is used to indicate the ACB has been tripped. This switch is activated whenever the off button of the overcurrent trip device, shunt drip device or undervoltage trip device is pressed.

3. Contact ratings

3-1. Contact ratings of Trip indicator and Spring change indicator

Voltage (V)	Switch contact ratings (A)	
	Resistive load	Inductive load
250 AC	3	3
250 DC	0.1	0.1
125 DC	0.5	0.5
30 DC	3	2

3-2. Contact ratings for other contacts

Voltage (V)	Current (A)			
	1. Single contact		2. Individual contacts	
	Resistive load	Inductive load	Resistive load	Inductive load
250 AC	3	3	0.5	0.2
250 DC	0.3	0.15	0.27	0.04
125 DC	0.5	0.25	0.5	0.2
30 DC	5	3	2	0.7

●:Standard ○:Optional

	Reverse power	N-phase protection	Ground fault on line side	Contact temperature monitoring	Reverse phase protection	Zone interlock	Output indication				Undervoltage alarm	Field test function	Control power
							Single contact	Individual contact	Spring charge indicator *1	Trip indicator *4			
	RPT *3	NP	REF *4	OH *4	NS *4	Z					UV *1*3		
	—	○	—	—	—	—	●	—	○	○	—	—	Not required
	—	○	—	—	—	—	●	—	○	○	—	—	Not required
	—	○	—	—	○	—	—	●	○	○	—	●	Required
	—	○	○	—	○	—	—	●	○	○	—	●	Required
	—	○	—	—	○	—	—	●	○	○	—	●	Required
	—	○	○	—	○	—	—	●	○	○	—	●	Required
	●	—	—	○	—	○	—	●	○	○	○	●	Required
	—	○	—	○	○	○	—	●	○	○	○	●	Required
	—	○	○	○	○	○	—	●	○	○	○	●	Required
	—	○	○	○	○	○	—	●	○	○	○	●	Required
	—	—	—	○	—	○	—	●	○	○	○	●	Required
	●	—	—	○	—	○	—	●	○	○	○	●	Required

Note: • When AGR-11B OCR with single-contact indication is activated, the corresponding operation LED indicator is momentarily ON or OFF. But the LED indicator is kept ON when the protection function is checked with the optional OCR checker.
• If the control power is not supplied or is lost, each function operates as follows:

LT, ST, INST, RPT	Operates normally.
GF	Operates normally. When the CT rated primary current [I _{CT}] is less than 800 A and the GF pick-up current is set to 10 %, the GF becomes inoperative.
MCR	Operates as INST.
PTA 1-channel	Is inoperative.
LED indicator on OCRs with single-contact indication	Is momentarily on or off.
Contact output from OCRs with single-contact indication	Turns off after 40 ms or more.
Contact output from OCRs with individual contact indication	Is inoperative.
LCD	No display
Field test facility	Is inoperative.

Air Circuit Breakers

DH series

■ General view

• AGR-11BL OCR (with L-characteristics)

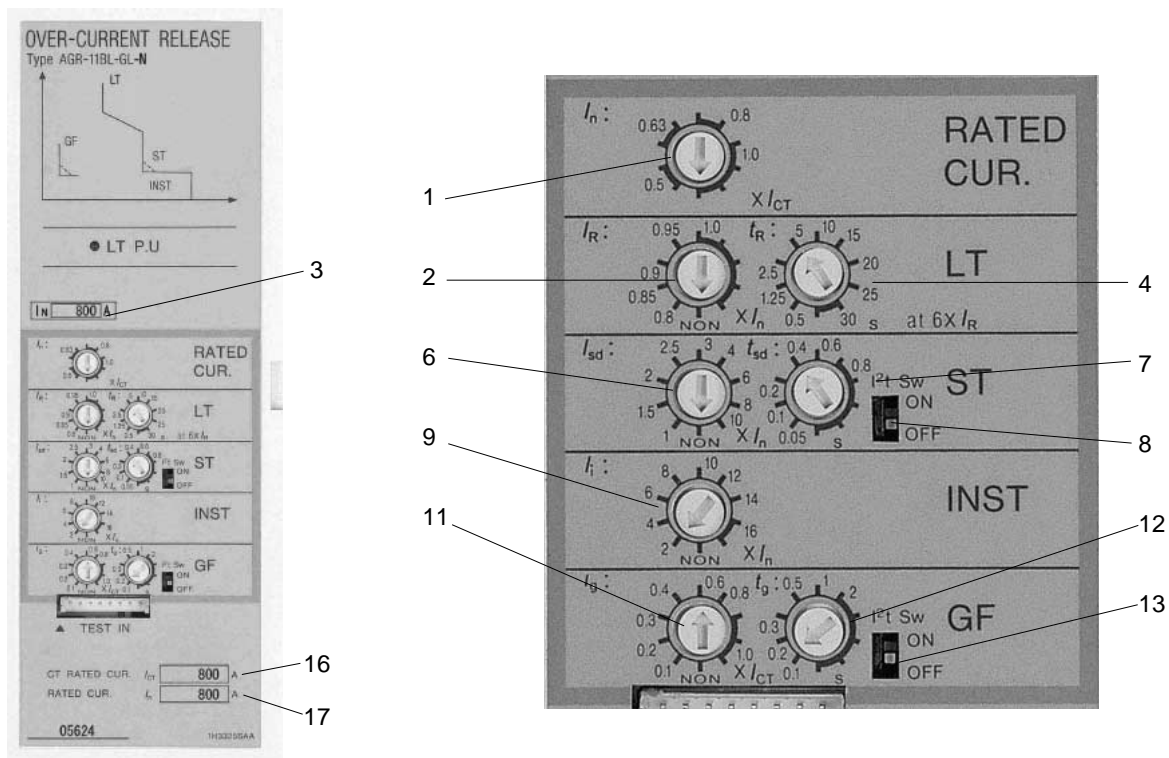

Setting item

1. Rated current
2. Long time delay trip pickup current (continuous)
3. N-phase protection trip pickup current (continuous)
4. Long time delay/N-phase protection trip timing
6. Short time delay trip pickup current
7. Short time delay trip timing
8. Short time delay trip I^2t mode
9. Instantaneous trip pickup current
11. Ground fault trip pickup current
12. Ground fault trip timing
13. Ground fault trip I^2t mode
16. CT rated primary current display-only field
17. Factory-set rated current display-only field

• AGR-21BL-PG OCR

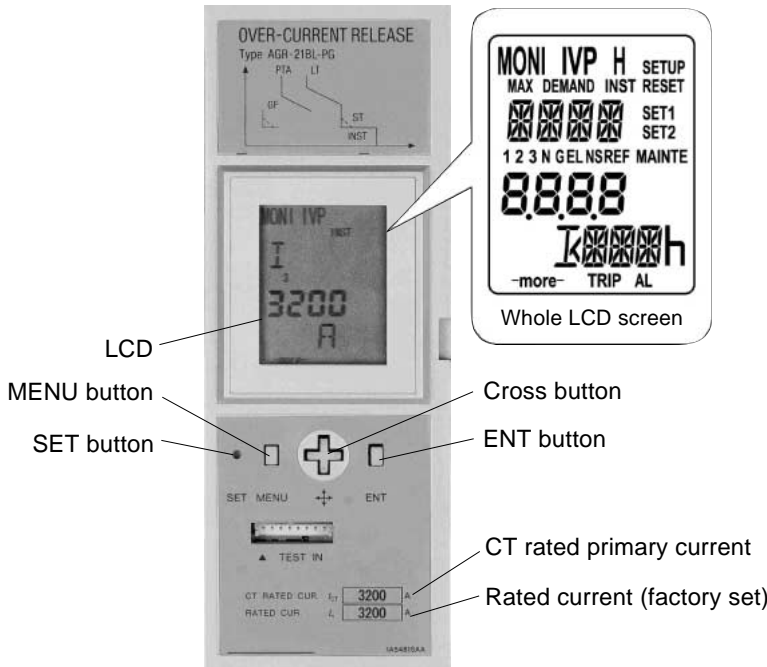

Button symbols and their meanings

- Ⓢ : Press the SET button using a pointed tool such as the tip of a pen.
- Ⓜ : Press the MENU button.
- ⬆ : Press the up key of the cross button.
- ⬇ : Press the down key of the cross button.
- ⬆ : Press the right key of the cross button.
- ⬅ : Press the left key of the cross button.
- ⓔ : Press the ENT button.

• AGR-31BL-PG OCR

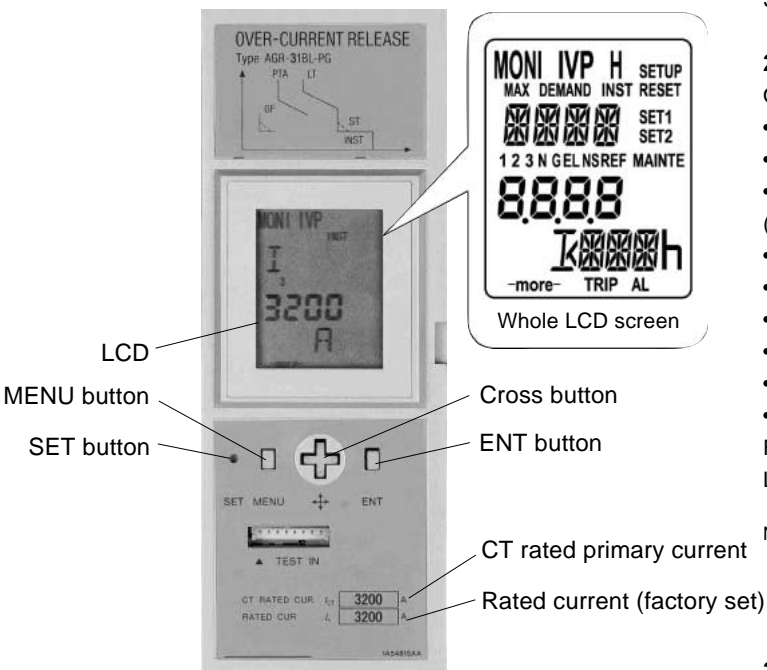

1. Button symbols and their meanings

Same as above.

2. Monitoring various data on L.C.D.

OCR can monitor,

- Phase current (A) of I₁, I₂, I₃ and their max. peak current
- Current (A) of I_N, I_g
- Line voltage (V) of V₁₂, V₂₃, V₃₁ and their max. peak voltage (or, Phase voltage (V) of V_{1N}, V_{2N}, V_{3N} and their peak voltage)
- Active power max. (kW)
- Demand active power max. (kW)
- Power factor (cos φ)
- Electric energy (kWh/ MWh/ GWh)
- Frequency (Hz)
- Trip history

Fault current is monitored, and the operation cause is indicated on LCD and via individual contacts.

Note : The supply voltage to the OCR for indicating the main circuit voltage or power must not exceed 250 VAC. If the main circuit voltage exceeds 250 VAC, a step-down power transformer is needed. When ordering the ACB, state the step-down ratio of the transformer you will use.

3. Gives the system alarm with number on the LCD for the following abnormal function.

- Trip function fail
- MHT circuit break

Air Circuit Breakers

DH series

■ Characteristics of overcurrent trip device

For general feeder circuit/L-characteristic (Type AGR-11BL, 21BL, 31BL)

Protection function		Setting range * <u> </u> : Default setting																					
Adjustable long time delay trip LT	Pick-up current I_R (A)	$I_n \times (0.8 - 0.85 - 0.9 - 0.95 - \underline{1.0} - \text{NON})$, 6 steps • Non-tripping at $I_R \times 1.05$ or less • Tripping between over $1.05I_R$ and $1.2I_R$ or less																					
	Time delay t_R (s) Tolerance of t_R (%)	$(0.5 - 1.25 - 2.5 - 5 - \underline{10} - 15 - 20 - 25 - 30)$ at $600\% \times I_R$, 9 steps $\pm 15\% +150\text{ms} -0\text{ms}$																					
Adjustable short time delay trip ST	Pick-up current I_{sd} (A) Tolerance of I_{sd} (%)	$I_n \times (1 - 1.5 - 2 - 2.5 - 3 - 4 - \underline{6} - 8 - 10 - \text{NON})$, 10 steps $\pm 15\%$																					
	Time delay t_{sd} (ms) Relay time (ms) Resettable time (ms) Total fault clearing time (ms)	<table style="width: 100%; border-collapse: collapse;"> <tr> <td style="text-align: center;">50</td> <td style="text-align: center;">100</td> <td style="text-align: center;">200</td> <td style="text-align: center;"><u>400</u></td> <td style="text-align: center;">600</td> <td style="text-align: center;">800</td> <td style="text-align: center;">6steps</td> </tr> <tr> <td style="text-align: center;">25</td> <td style="text-align: center;">75</td> <td style="text-align: center;">175</td> <td style="text-align: center;">375</td> <td style="text-align: center;">575</td> <td style="text-align: center;">775</td> <td></td> </tr> <tr> <td style="text-align: center;">120</td> <td style="text-align: center;">170</td> <td style="text-align: center;">270</td> <td style="text-align: center;">470</td> <td style="text-align: center;">670</td> <td style="text-align: center;">870</td> <td></td> </tr> </table>	50	100	200	<u>400</u>	600	800	6steps	25	75	175	375	575	775		120	170	270	470	670	870	
	50	100	200	<u>400</u>	600	800	6steps																
	25	75	175	375	575	775																	
	120	170	270	470	670	870																	
Pick-up current I_{li} (A) Tolerance of I_{li} (%)	$I_n \times (2 - 4 - 6 - 8 - 10 - 12 - 14 - \underline{16} - \text{NON})$, 9 steps $\pm 20\%$																						
Pick-up current I_{P1} (A) Tolerance of I_{P1} (%) Time delay t_{P1} (s) Tolerance of t_{P1} (%)	$I_n \times (0.75 - 0.8 - 0.85 - 0.9 - \underline{0.95} - 1.0)$, 6 steps $\pm 7.5\%$ $(5 - 10 - 15 - 20 - 40 - 60 - 80 - \underline{120} - 160 - 200)$ at I_{P1} or more, 10 steps $\pm 15\% +100\text{ms} -0\text{ms}$																						
Adjustable ground fault trip GF	Pick-up current I_g (A) Tolerance of I_g (%)	$I_{ct} \times (0.1 - \underline{0.2} - 0.3 - 0.4 - 0.6 - 0.8 - 1.0 - \text{NON})$, 8 steps $\pm 20\%$																					
	Time delay t_g (ms) Relay time (ms) Resettable time (ms) Total fault clearing time (ms)	<table style="width: 100%; border-collapse: collapse;"> <tr> <td style="text-align: center;">100</td> <td style="text-align: center;">200</td> <td style="text-align: center;"><u>300</u></td> <td style="text-align: center;">500</td> <td style="text-align: center;">1000</td> <td style="text-align: center;">2000</td> <td style="text-align: center;">6 steps</td> </tr> <tr> <td style="text-align: center;">75</td> <td style="text-align: center;">175</td> <td style="text-align: center;">275</td> <td style="text-align: center;">475</td> <td style="text-align: center;">975</td> <td style="text-align: center;">1975</td> <td></td> </tr> <tr> <td style="text-align: center;">170</td> <td style="text-align: center;">270</td> <td style="text-align: center;">370</td> <td style="text-align: center;">570</td> <td style="text-align: center;">1070</td> <td style="text-align: center;">2070</td> <td></td> </tr> </table>	100	200	<u>300</u>	500	1000	2000	6 steps	75	175	275	475	975	1975		170	270	370	570	1070	2070	
	100	200	<u>300</u>	500	1000	2000	6 steps																
	75	175	275	475	975	1975																	
	170	270	370	570	1070	2070																	
Pick-up current $[I_{REF}]$ (A) Current setting tolerance (%) Time-delay (s)	$[I_{ct}] \times (0.1 - \underline{0.2} - 0.3 - 0.4 - 0.6 - 0.8 - 1.0 - \text{NON})$, 8 steps $\pm 20\%$ Inst																						
Pick-up current I_N (A) Time delay t_N (s) Tolerance of t_N (%)	$I_{ct} \times (0.4 - 0.5 - 0.63 - 0.8 - 1.0)$ Factory set to a user-specified value • Non-tripping at $1.05 I_N$ or less • Tripping range: Between over $1.05I_N$ and $1.2I_N$ or less Long time delay (LT) trip at 600% of I_N $\pm 15\% +150\text{ms} -0\text{ms}$																						
Reverse phase protection NS (AGR-21B, 31B only)	Pick-up current $[I_{NS}]$ (A) Current setting tolerance (%) Time-delay $[t_{NS}]$ (s) Time-delay tolerance (%)	$[I_n] \times (0.2 - 0.3 - \underline{0.4} - 0.5 - 0.6 - 0.7 - 0.8 - 0.9 - 1.0)$, 9 steps $\pm 10\%$ At 150% current of $[I_{NS}]$, $0.4 - 0.8 - 1.2 - 1.6 - 2 - 2.4 - 2.8 - 3.2 - 3.6 - \underline{4}$, 10 steps $\pm 20\% +150\text{ms} -0\text{ms}$																					
	Recovery setting voltage (V) Recovery voltage tolerance (%) Setting voltage (V) Setting voltage tolerance (%) Time delay (s) Time delay tolerance (%)	$[V_n] \times (0.8 - \underline{0.85} - 0.9 - 0.95)$, 4 steps $\pm 5\%$ $[V_n] \times (0.4 - \underline{0.6} - 0.8)$, 3 steps $\pm 5\%$ $0.1 - 0.5 - \underline{1} - 2 - 5 - 10 - 15 - 20 - 30 - 36$, 10 steps $\pm 5\% +100\text{ms} -0\text{ms}$																					
	Control power	100 to 120V AC) common 100 to 125V DC) common 24V DC) common 200 to 240V AC) common 200 to 250V DC) common 48V DC) common Power consumption: 5VA																					

• Values of [I_{CT}] and [I_n] 11BL, 21BL, 31BL

Type	CT rated primary current [I _{CT}] (A)	Rated current [I _n] (A)				Remarks
		[I _{CT}] x 0.5	[I _{CT}] x 0.63	[I _{CT}] x 0.8	[I _{CT}] x 1.0	
DH08	200	100	125	160	200	There are no difference by terminal structure and safety standards
	400	200	250	320	400	
	800	400	500	630	800	
DH12	400	200	250	320	400	There are no difference by terminal structure and safety standards
	800	400	500	630	800	
	1250	630	800	1000	1250	
DH16	400	200	250	320	400	There are no difference by terminal structure and safety standards
	800	400	500	630	800	
	1250	630	800	1000	1250	
	1600	800	1000	1250	1600	IEC, JIS
		800	1000	1250	1600	NEMA, ANSI / Vertical terminals
800	1000	1250	–	NEMA, ANSI / Horizontal terminals, Front terminals		
DH20	400	200	250	320	400	There are no difference by terminal structure and safety standards
	800	400	500	630	800	
	1250	630	800	1000	1250	
	1600	800	1000	1250	1600	
	2000	1000	1250	1600	2000	IEC, JIS
1000		1250	1600	2000	NEMA, ANSI / Vertical terminals	
1000		1250	1600	–	NEMA, ANSI / Horizontal terminals, Front terminals	
DH25	2500	1250	1600	2000	2500	Vertical terminals
		1250	1600	2000	2500	IEC, JIS / Front terminals
		1250	1600	2000	–	IEC, JIS / Horizontal terminals
		1250	1600	2000	–	NEMA, ANSI / Horizontal terminals, Front terminals
DH30	3200	1600	2000	2500	3200	Vertical terminals
		1600	2000	2500	–	Horizontal terminals, Front terminals
DH40	4000	2000	2500	3200	4000	IEC, JIS
		2000	2500	3200	–	NEMA, ANSI
DH50	5000	2500	3200	4000	5000	IEC, JIS
DH60	6300	3200	4000	5000	6300	IEC, JIS
DH12H	200	100	125	160	200	There are no difference by terminal structure and safety standards
	400	200	250	320	400	
	800	400	500	630	800	
	1250	630	800	1000	1250	
DH16H	1600	800	1000	1250	1600	IEC, JIS
		800	1000	1250	1600	NEMA, ANSI / Vertical terminals
		800	1000	1250	–	NEMA, ANSI / Horizontal terminals
DH20H	2000	1000	1250	1600	2000	IEC, JIS
		1000	1250	1600	2000	NEMA, ANSI / Vertical terminals
		1000	1250	1600	–	NEMA, ANSI / Horizontal terminals
DH16P	200	100	125	160	200	There are no difference by terminal structure and safety standards
	400	200	250	320	400	
	800	400	500	630	800	
	1250	630	800	1000	1250	
	1600	800	1000	1250	1600	
DH20P	2000	1000	1250	1600	2000	There are no difference by terminal structure and safety standards
DH25P	2500	1250	1600	2000	2500	Vertical terminals
		1250	1600	2000	–	Horizontal terminals
DH30P	3200	1600	2000	2500	3200	Vertical terminals
		1600	2000	2500	–	Horizontal terminals

Air Circuit Breakers DH series

Protection characteristics

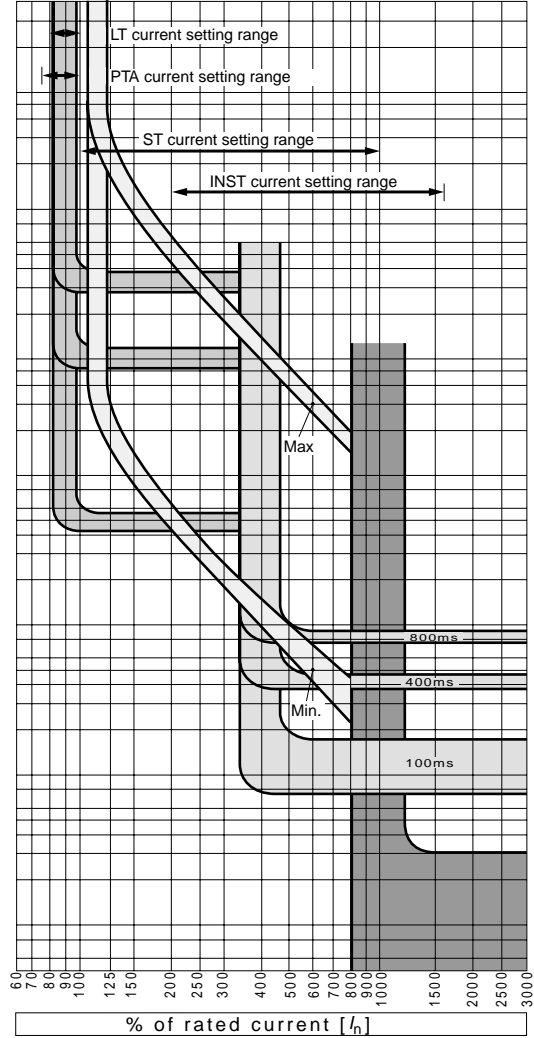
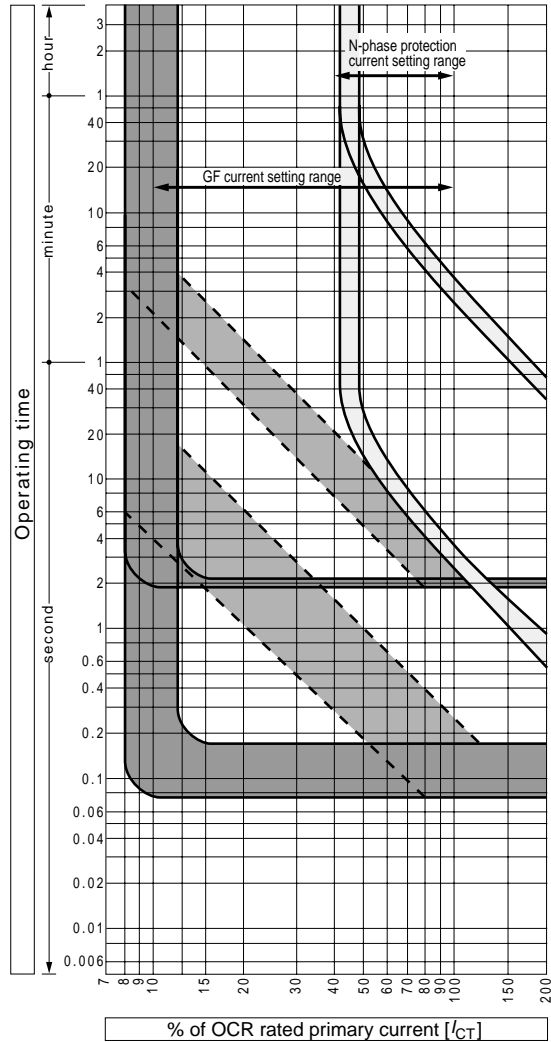

The ST trip characteristic shown in the figure applies when the ramp characteristic select switch is in the OFF position.

■ Characteristics of overcurrent trip device

For general feeder circuit/R-characteristic (Type AGR-21BR, 31BR)

Protection function		Setting range * ___ : Default setting
Adjustable long time delay trip LT	Pick-up current I_R (A)	Select one from among $I^{002}T$, IT , I^2T , I^3T , and I^4T by LCD. $I_R \times (0.8 - 0.85 - 0.9 - 0.95 - \underline{1.0} - \text{NON})$, 6 steps • Non-tripping at $I_R \times 1.05$ or less • Tripping between over $1.05I_R$ and $1.2I_R$ or less
	Time delay t_R (s) Tolerance of t_R (%)	(1 — 2 — 3 — 4 — <u>5</u> — 6.3 — 6.8 — 10) at 300% $\times I_R$, 8 steps $\pm 20\%$ +150ms -0ms
Adjustable short time delay trip ST	Pick-up current I_{sd} (A) Tolerance of I_{sd} (%)	$I_n \times (1 - 1.5 - 2 - 2.5 - 3 - 4 - \underline{6} - 8 - 10 - \text{NON})$, 10 steps $\pm 15\%$
	Time delay t_{sd} (ms) Relay time (ms) Resettable time (ms) Total fault clearing time (ms)	50 100 200 <u>400</u> 600 800, 6 steps 25 75 175 <u>375</u> 575 775 120 170 270 470 670 870
Adjustable instantaneous trip INST or MCR	Pick-up current I_i (A) Tolerance of I_i (%)	$I_n \times (2 - 4 - 6 - 8 - 10 - 12 - 14 - \underline{16} - \text{NON})$, 9 steps $\pm 20\%$
Adjustable pre-trip alarm PTA	Pick-up current I_{P1} (A) Tolerance of I_{P1} (%) Time delay t_{P1} (s) Tolerance of t_{P1} (%)	$I_n \times (0.75 - 0.8 - 0.85 - 0.9 - \underline{0.95} - 1.0)$, 6 steps $\pm 7.5\%$ (5 — 10 — 15 — 20 — 40 — 60 — 80 — <u>120</u> — 160 — 200) at I_{P1} or more, 10 steps $\pm 15\%$ +100ms -0ms
Adjustable ground fault trip GF	Pick-up current I_g (A) Tolerance of I_g (%)	$I_{CT} \times (0.1 - \underline{0.2} - 0.3 - 0.4 - 0.6 - 0.8 - 1.0 - \text{NON})$, 8 steps $\pm 20\%$
	Time delay t_g (ms) Relay time (ms) Resettable time (ms) Total fault clearing time (ms)	100 200 <u>300</u> 500 1000 2000, 6 steps 75 175 275 475 975 1975 170 270 370 570 1070 2070
Ground fault trip on line side REF	Pick-up current $[I_{REF}]$ (A) Current setting tolerance (%) Time-delay (s)	$[I_{CT}] \times (0.1 - \underline{0.2} - 0.3 - 0.4 - 0.6 - 0.8 - 1.0 - \text{NON})$, 8 steps $\pm 20\%$ Inst
Neutral phase protection function NP	Pick-up current I_N (A)	$I_{CT} \times (\underline{0.4} - 0.5 - 0.63 - 0.8 - 1.0)$ Factory set to a user-specified value • Non-tripping at $1.05 I_N$ or less • Tripping between over $1.05 I_N$ and $1.2 I_N$ or less
	Time delay t_N (s) Tolerance of t_N (%)	Long time delay (LT) trip at 300% of I_N $\pm 20\%$ +150ms -0ms
Reverse phase protection NS	Pick-up current $[I_{NS}]$ (A) Current setting tolerance (%) Time-delay $[t_{NS}]$ (s) Time-delay tolerance (%)	$[I_N] \times (0.2 - 0.3 - \underline{0.4} - 0.5 - 0.6 - 0.7 - 0.8 - 0.9 - 1.0)$, 9 steps $\pm 10\%$ At 150% current of $[I_{NS}]$, 0.4 — 0.8 — 1.2 — 1.6 — 2 — 2.4 — 2.8 — 3.2 — 3.6 — <u>4</u> , 10 steps $\pm 20\%$ +150ms -0ms
Undervoltage alarm UV (AGR-31B only)	Recovery setting voltage (V) Recovery voltage tolerance (%)	$[V_n] \times (0.8 - \underline{0.85} - 0.9 - 0.95)$, 4 steps $\pm 5\%$
	Setting voltage (V) Setting voltage tolerance (%) Time delay (s) Time delay tolerance (%)	$[V_n] \times (0.4 - \underline{0.6} - 0.8)$, 3 steps $\pm 5\%$ 0.1 — 0.5 — 1 — 2 — 5 — 10 — 15 — 20 — 30 — 36, 10 steps $\pm 5\%$ +100ms -0ms
Control power		100 to 120V AC) common 100 to 125V DC) common 24V DC) common 200 to 240V AC) common 200 to 250V DC) common 48V DC) common
		Power consumption: 5VA

Air Circuit Breakers

DH series

• Values of [I_{CT}] and [I_n] 21BR, 31BR

Type	CT rated primary current [I _{CT}] (A)	Rated current [I _n] (A)				Remarks
		[I _{CT}] x 0.5	[I _{CT}] x 0.63	[I _{CT}] x 0.8	[I _{CT}] x 1.0	
DH08	200	100	125	160	200	There are no difference by terminal structure and safety standards
	400	200	250	320	400	
	800	400	500	630	800	
DH12	400	200	250	320	400	There are no difference by terminal structure and safety standards
	800	400	500	630	800	
	1250	630	800	1000	1250	
DH16	400	200	250	320	400	There are no difference by terminal structure and safety standards
	800	400	500	630	800	
	1250	630	800	1000	1250	
	1600	800	1000	1250	1600	IEC, JIS
		800	1000	1250	1600	NEMA, ANSI / Vertical terminals
800		1000	1250	–	NEMA, ANSI / Horizontal terminals, Front terminals	
DH20	400	200	250	320	400	There are no difference by terminal structure and safety standards
	800	400	500	630	800	
	1250	630	800	1000	1250	
	1600	800	1000	1250	1600	
	2000	1000	1250	1600	2000	IEC, JIS
1000		1250	1600	2000	NEMA, ANSI / Vertical terminals	
1000		1250	1600	–	NEMA, ANSI / Horizontal terminals, Front terminals	
DH25	2500	1250	1600	2000	2500	Vertical terminals
		1250	1600	2000	2500	IEC, JIS / Front terminals
		1250	1600	2000	–	IEC, JIS / Horizontal terminals
		1250	1600	2000	–	NEMA, ANSI / Horizontal terminals, Front terminals
DH30	3200	1600	2000	2500	3200	Vertical terminals
		1600	2000	2500	–	Horizontal terminals, Front terminals
DH40	4000	2000	2500	3200	4000	IEC, JIS
		2000	2500	3200	–	NEMA, ANSI
DH50	5000	2500	3200	4000	5000	IEC, JIS
DH60	6300	3200	4000	5000	6300	IEC, JIS
DH12H	200	100	125	160	200	There are no difference by terminal structure and safety standards
	400	200	250	320	400	
	800	400	500	630	800	
	1250	630	800	1000	1250	
DH16H	1600	800	1000	1250	1600	IEC, JIS
		800	1000	1250	1600	NEMA, ANSI / Vertical terminals
		800	1000	1250	–	NEMA, ANSI / Horizontal terminals
DH20H	2000	1000	1250	1600	2000	IEC, JIS
		1000	1250	1600	2000	NEMA, ANSI / Vertical terminals
		1000	1250	1600	–	NEMA, ANSI / Horizontal terminals
DH16P	200	100	125	160	200	There are no difference by terminal structure and safety standards
	400	200	250	320	400	
	800	400	500	630	800	
	1250	630	800	1000	1250	
	1600	800	1000	1250	1600	
DH20P	2000	1000	1250	1600	2000	There are no difference by terminal structure and safety standards
DH25P	2500	1250	1600	2000	2500	Vertical terminals
		1250	1600	2000	–	Horizontal terminals
DH30P	3200	1600	2000	2500	3200	Vertical terminals
		1600	2000	2500	–	Horizontal terminals

Protection characteristics

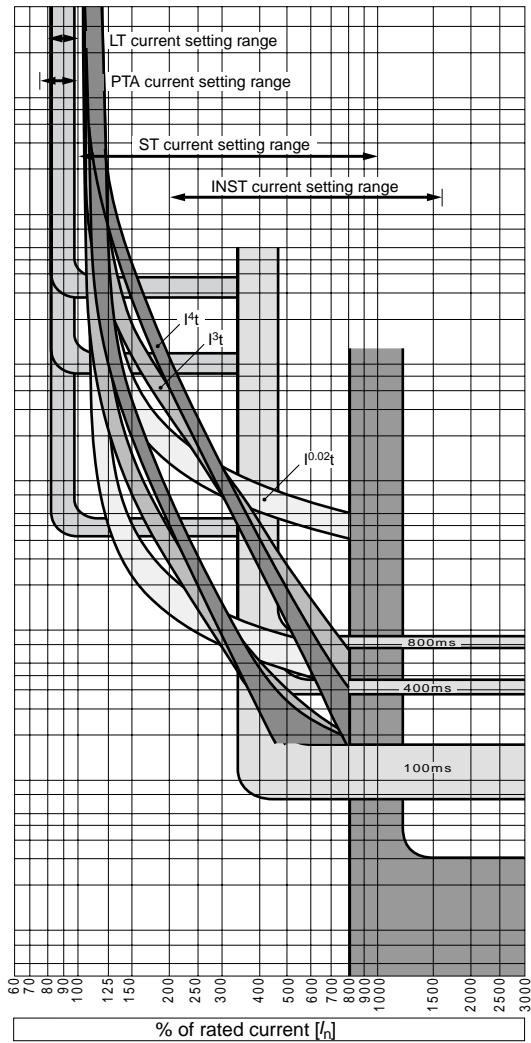
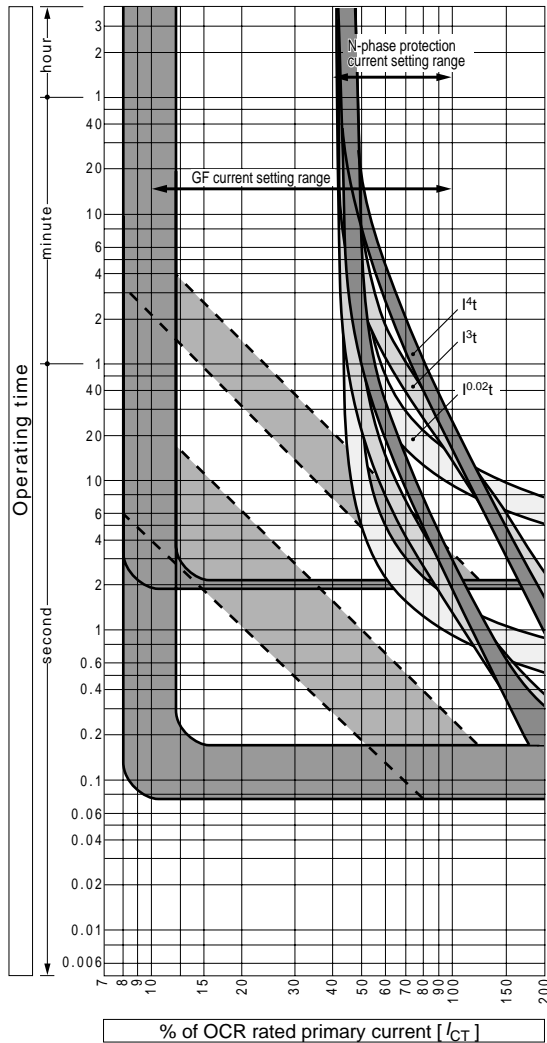

The ST trip characteristic shown in the figure applies when the ramp characteristic select switch is in the OFF position.

Air Circuit Breakers

DH series

■ Supplied accessories

• ON-OFF operation counter

The ON-OFF operation counter is a mechanical 5-digit readout that shows the number of ON-OFF operations of the ACB.

Counter readings serve as a guide for maintenance or inspection.



• Auxiliary switches

The 7PDT auxiliary switches operate during the ACB ON/OFF operation.

Connections to the switches are made via screw terminals. The auxiliary switches for draw-out type ACBs operate in the CONNECTED and TEST positions.

The auxiliary switches for ACBs conforming to marine use rules which operate in the CONNECTED position only.

Auxiliary switch ratings

Category	For general use		
	Resistive load (A)	Inductive load (A)	AC: $\cos \phi \geq 0.3$ DC: $L/R \leq 0.01$
100-250V AC	5		5
251-500V AC	5		5
30V DC	1		1
125-250V DC	1		1

Notes *1: The chattering of NC-contacts due to ON/OFF operation of the ACB should be less than 20 ms.

*2: Do not supply different voltages to contacts of a switch.

• Position padlock lever

Using the position padlock lever prevents the breaker body from inadvertently being drawn out. The position padlock lever in the pulled-out position locks the breaker body in the CONNECTED, TEST, or ISOLATED position. Up to three padlocks (with 6mm dia. hasp) can be installed.



• ON-OFF button cover

An ON-OFF button cover (supplied as standard) prevents inadvertent or unauthorized operation of the ON or OFF button. It can be locked with up to three padlocks with 6mm dia. hasp.

Padlocks are not supplied.



• Draw-out handle

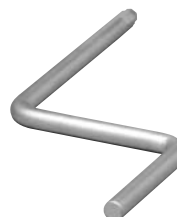

■ Optional accessories

• Auxiliary switches

The auxiliary switches operate during the ACB ON/OFF operation.

Connections to the switches are made via screw terminals. The auxiliary switches for draw-out type ACBs operate in the CONNECTED and TEST positions.

The auxiliary switches for ACBs conforming to marine classification society's rules operate in the CONNECTED position only.

The auxiliary switches are available for general use and for microload.

Auxiliary switch arrangement

For general use	For microload
4PDT	—
4PDT	3PDT
10PDT	—
7PDT	3PDT

Auxiliary switch ratings

Voltage	For general use			For microload			Min. applicable load
	Resistive load (A)	Inductive load (A)	AC: $\cos \phi \geq 0.3$ DC: $L/R \leq 0.01$	Resistive load (A)	Inductive load (A)	AC: $\cos \phi \geq 0.6$ DC: $L/R \leq 0.007$	
100-250V AC	5	5	5	0.1	0.1	0.1	5V DC 1mA
251-500V AC	5	5	5	—	—	—	
30V DC	1	1	1	0.1	0.1	0.1	
125-250V DC	1	1	1	—	—	—	

Notes 1: The chattering of NC-contacts due to ON-OFF operation of the ACB should be less than 20 ms.

Notes 2: Do not supply different voltages to contacts of a switch.

● Key lock

There are two types of keylock: "Lock-in-OFF type" which prevents the breaker from being CLOSED and "Lock-in-ON type" prevents it from being OPENED.

When the ACB is fitted with a key lock, the operator cannot operate the ACB unless using a matched key.



- A key must be inserted to release the lock before the ACB can be closed.
- The ACB must be opened and locked in the OFF position before the key can be removed.

By utilizing the lock-in OFF type key lock feature, and then a limited number of keys by default provides an effective and reliable interlock system.

Using the same keys also allows interlocking between an ACB and other devices (such as a switchboard door).

ACBs are supplied with a cylinder lock or with a provision for type FS-2 Castell lock (with angular movement 90° clockwise to trap key).

The Castell lock is not supplied.

● Key interlock

The key interlock is a system of interlocking between ACBs, each fitted with a key lock of lock-in OFF type.

Example: Interlock for prevention of parallel feeding of two power supplies when a bus-tie breaker is used.

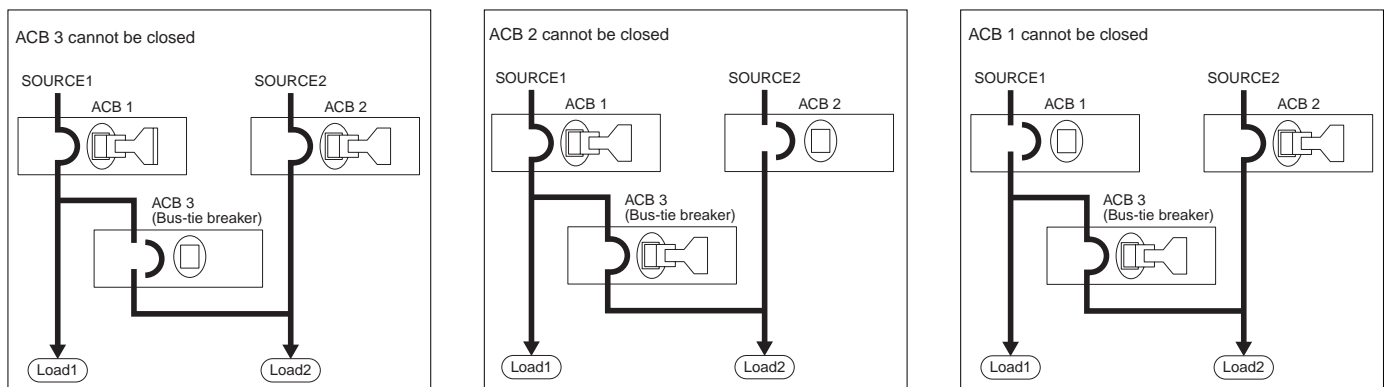

Air Circuit Breakers

DH series

■ Optional accessories

• Mechanical interlock

Mechanical interlocks for interlocking 2 or 3 ACBs in either horizontal (Draw-out type and fixed type) or vertical (Draw-out type only) arrangements are available.

Interlocking is possible between any frame size of DH series ACB.

In conjunction with an electrical interlock, it will enhance safety and reliability of power distribution systems.

1. Horizontal type

This table shows the standard pitch between left side ACB A and right side ACB B, or between left side ACB B and right side ACB C.

Left ACB		Right ACB	Pitch of ACB P (mm) (PC line to PC line)			
			DH08 to DH20 DH12H to DH20H	DH25 to DH30 DH16P to DH30P	DH40	DH50 DH60
			3P, 4P	3P, 4P	3P, 4P	3P, 4P
DH08 to DH20	3P		600, 700, 800	600, 700, 800	500, 600, 700	800, 1000, 1100
	4P		600, 700, 800, 900	700, 800, 900	600, 700, 800	900, 1000, 1100
DH12H to DH20H	3P		600, 700, 800, 900	700, 800, 900	700, 800, 900	900, 1000, 1100
	4P		700, 800, 900, 1000	800, 900, 1000	800, 900, 1000	1000, 1100, 1200
DH25 to DH30	3P		800, 900, 1000, 1100	900, 1000, 1100	800, 900, 1000	1100, 1200, 1300
	4P		1000, 1100, 1200, 1300	1000, 1100, 1200	1000, 1100, 1200	1300, 1400
DH40	3P		700, 800, 900, 1000	800, 900, 1000	700, 800, 900, 1000	1000, 1100, 1200
	4P		1000, 1100, 1200	1000, 1100, 1200	1000, 1100, 1200	1200, 1300, 1400
DH50 DH60	3P					
	4P					

When ordering, select the required pitch for P1 and P2 from the above table, and specify the type and number of poles for ACB A, ACB B, and ACB C if exists.

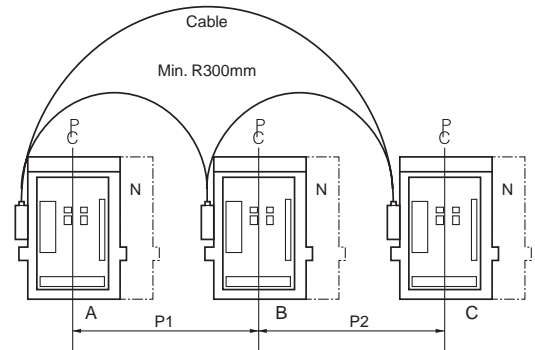

2. Vertical type

Minimum pitch (550mm) is possible.

Specify the required pitch when ordering.

Maximum is 1200mm.

Contact FUJI for the details of vertical type with 3 ACBs.

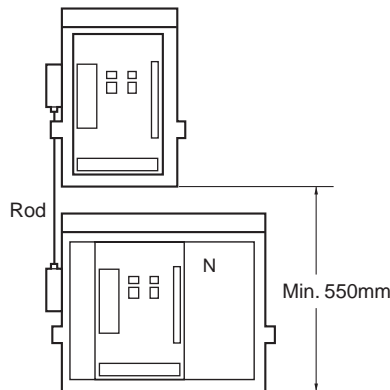

• Automatic closing spring release

This device allows the charged closing springs to be automatically released when the ACB is drawn out from the ISOLATED position to the DRAW-OUT position.

ANSI or NEMA-compliant ACBs require this option.

• Spring charge indicator

This switch can be used to indicate that the closing springs have been fully charged.

For the contact ratings of the switch, see the table 3-1 on page 06/181.

• Control circuit terminal cover

A control circuit terminal cover protects the terminal blocks for auxiliary switches, position switches, and control circuits from being accidentally touched, thus enhancing safety.

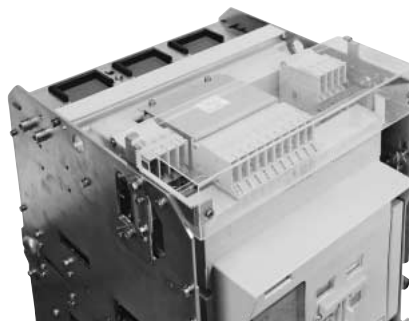

■ Optional accessories

• Door flange

A door flange can be used as a decoration panel that covers the cutout on the switchboard panel, and provides IP20 protection. For IP31 protection, please specify the door flange with a gasket.

Note: Door flange cannot be specified with door interlock.

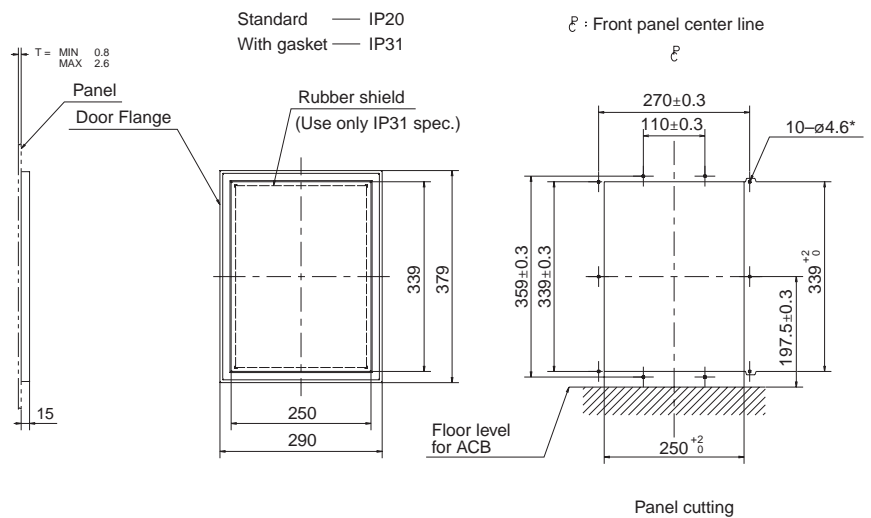

*: Mount IP20 door flange through 6 mounting holes and IP31 door flange through 10 mounting holes.

• OFF padlock

Permits the ACB to be padlocked in the OFF position. Max. three padlocks with 6mm dia. hasp can be fitted. Padlocking is possible only when ON-OFF indicator shows OFF. When the ACB is padlocked in the OFF position, both manual and electrical closing become inoperative, but the charging of the closing spring by manual or motor is still possible.

Note: OFF padlock facility cannot be fitted with key lock or key interlock.

• Interface barrier

An interface barrier prevents a possible short-circuit due to foreign objects entering between the poles of the main circuit terminals or between the line and load ends, thus enhancing operational reliability of the ACB.

This barrier cannot be applied to ACBs that are supplied with front connections or a reverse power trip function.

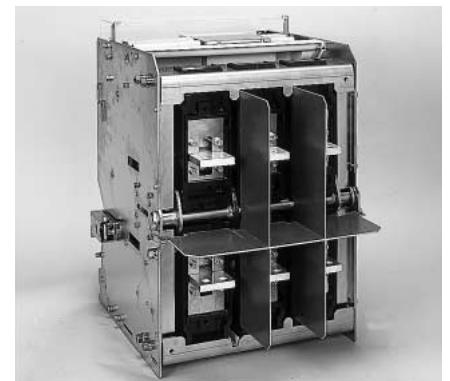

• Earthing device

There is a growing demand in L.V. distribution for greater protection against electric shock particularly during periods when maintenance work is being carried out on the main busbars or cables. A safe and economical way to meet this requirement is to apply system earthing via the normal service breaker. Earthing devices on FUJI ACBs comprises; permanent parts which are factory fitted by FUJI and are mounted on the ACB chassis and body to enable the ACB to receive the portable parts. Portable parts are supplied in loose kit form and are fitted on to the ACB body by the

customer's engineer. This converts the ACB from a normal service device to an earthing device.

When the ACB is converted to the earthing device mode, the over current release and the other electrical tripping devices are automatically disabled to prevent the remote opening of the ACB.

It is recommended that the ON-OFF operating buttons be padlocked to prevent manual opening of the ACB when used in the earthing mode.

UVT function cannot be applied to the earthing device.

Air Circuit Breakers

DH series

■ Optional accessories

• IP cover

An IP cover provides an IP55 grade of protection as required in IEC 60529. Even if the breaker body is on the ISOLATED position, IP cover can still be fitted on the ACB.

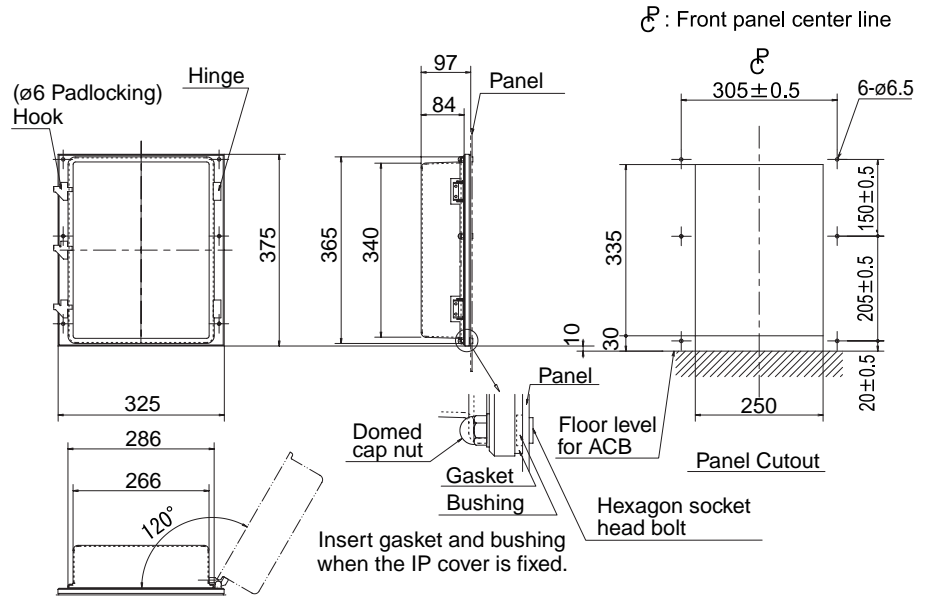

• OCR checker, type ANU-1

The OCR checker allows easy checking of the long time-delay trip, short time-delay trip, instantaneous trip, ground fault trip functions and the pre-trip alarm function of the OCR in the field.

Ratings and specifications

Power supply • 100–110V AC, 50/60Hz
or
100–240V AC, 50/60Hz
with type C plug
• 4 x AA alkaline cells

Power consumption	7VA
Dimensions	101 (W) x 195 (H) x 44 (D) mm
Mass	400 g



• Current transformer for neutral line (separately installed)

When using a 3-pole ACB with the ground fault protection function to protect a 3-phase, 4-wire system against ground fault, install an appropriate current transformer (CT) to the neutral line of the system. FUJI can provide this neutral line CT as an option. For the 4-pole ACB, a measuring CT instead of the neutral line CT is already built into the ACB with ground fault protection function.

Dimensions, mm

CW80-40LS

DH08, DH12, DH16
DH12H, DH16H, DH16P

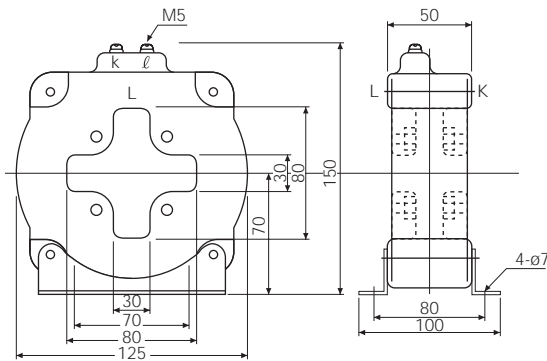

Type	Rated primary current
CW80-40LS	200, 400, 800, 1250, 1600

Rated secondary current is 5A.

EC160-40LS

DH20, DH25, DH30, DH40, DH50, DH60
DH20H, DH20P, DH25P, DH30P

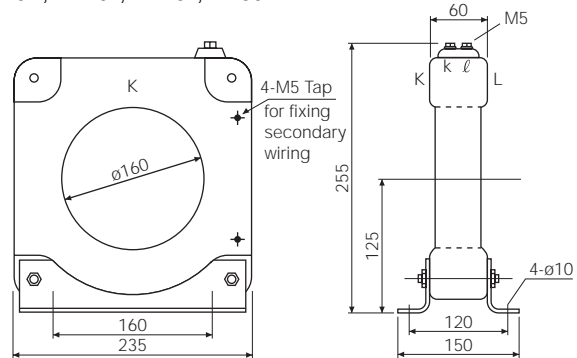

Type	Rated primary current
EC160-40LS	1600, 2000, 2500, 3200, 4000, 5000, 6300

Rated secondary current is 5A.

■ **Optional accessories (for draw-out type)**

• **Main circuit safety shutters**

The main circuit safety shutters automatically conceal the main circuit contacts on the draw-out cradle when the ACB is drawn out.

- The top and bottom shutters operate independently and can be separately padlocked in the closed position.
- Up to three padlocks (with 6mm dia. hasp) can be installed on each side using padlocking unit. (Padlock not supplied)
- In the closed position, the shutters are locked to the extent that they cannot be easily unlocked by hand. They can be unlocked and held open if required for the purpose of inspection or maintenance.



• **Control circuit safety shutter**

The control circuit safety shutter covers the control circuit contacts, ensuring safety.

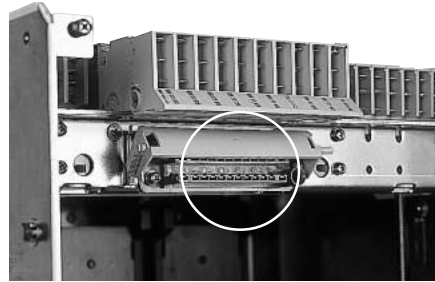

• **Breaker fixing bolts**

The breaker fixing bolts hold the breaker body securely to the draw-out cradle in position. Use them if the ACB is subject to strong vibration.



• **Test jumper**

The test jumper is a plug-in type, and allows ON-OFF tests on all the DH series ACBs with the breaker body drawn out from the draw-out cradle. The standard jumper cable is 5m long.

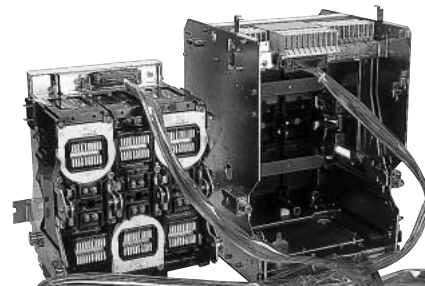

• **Mal-insertion prevention device**

Interchangeability exists within the DH series ACBs. Because of this feature, there is a possibility for an ACB of a different specification being placed into the draw-out cradle. Using the mal-insertion prevention device eliminates such a possibility. This device is capable of distinguishing nine different breaker bodies.



• **Lifter**

A special lifter is available to allow easy and safe transportation or installation of the ACB. A drop prevention mechanism is standard.

ACB mounting position

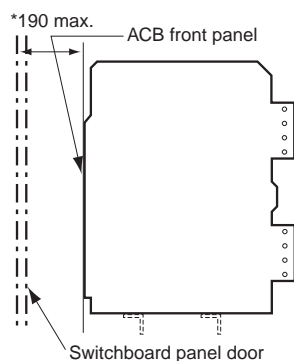

*: If 190 mm is exceeded, contact FUJI.

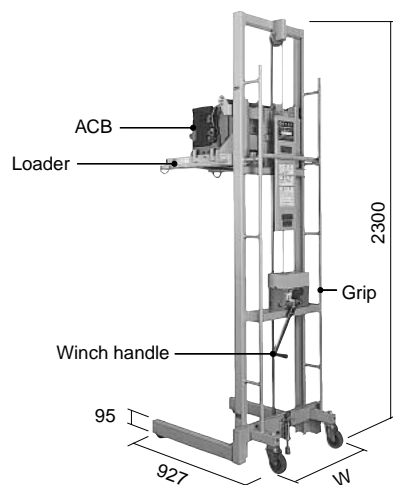

• **Lifting plate**

Lifting plates are detachable tools that can be used to lift a breaker body out of a draw-out cradle.

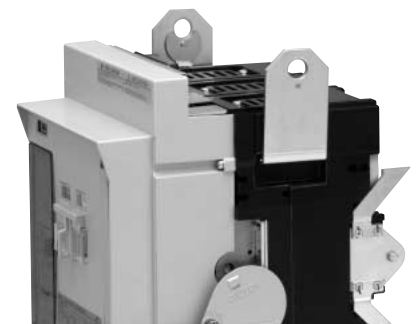

Type of Lifter	Mass (kg)	W (mm)	Applicable ACBs
AWR-1F	110	700	800 to 3200A
AWR-2F	120	890	800 to 4000A

Air Circuit Breakers

DH series

■ Optional accessories (for draw-out type)

• Position switches

The position switches operate to give indication of breaker positions: CONNECTED, TEST, ISOLATED, and INSERT. There are two contact arrangements: 2PDT and 4PDT.

Type	Number of contacts	Contact arrangement			
		INSERT	ISOLATED	TEST	CONN
ALR-0110P	2PDT	0	1	1	0
ALR-0101P		0	1	0	1
ALR-0011P		0	0	1	1
ALR-0200P		0	2	0	0
ALR-0020P		0	0	2	0
ALR-0002P		0	0	0	2
ALR-1111P		1	1	1	1
ALR-1210P		1	2	1	0
ALR-1201P		1	2	0	1
ALR-0211P		0	2	1	1
ALR-1120P	1	1	2	0	
ALR-1021P	1	0	2	1	
ALR-0121P	0	1	2	1	
ALR-1102P	1	1	0	2	
ALR-1012P	1	0	1	2	
ALR-0112P	0	1	1	2	
ALR-0220P	4PDT	0	2	2	0
ALR-0202P		0	2	0	2
ALR-0022P		0	0	2	2
ALR-1030P		1	0	3	0
ALR-0130P		0	1	3	0
ALR-0031P		0	0	3	1
ALR-1003P		1	0	0	3
ALR-0103P		0	1	0	3
ALR-0013P		0	0	1	3
ALR-0040P		0	0	4	0
ALR-0004P	0	0	0	4	

• Door interlock

The door interlock prevents the switchboard door from being opened unless the breaker body is in the ISOLATED position. When the draw-out handle is removed while the ACB is in the ISOLATED position, the interlock is released and the switchboard door can be opened.

The breaker body cannot be inserted unless the switchboard door is closed.

Contact FUJI for details.

• Step-down transformer

See page 06/176.

• Capacitor trip device

See page 06/177.

• Undervoltage trip device

See page 06/178.

Connections to the switches are made via tab or screw type terminals.

The following table lists the available types of the switches.

Position switch operation sequence

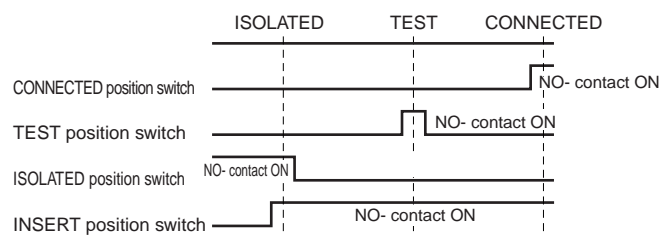

The INSERT position means the breaker body is in a position between ISOLATED and CONNECTED.

Position switch ratings

Voltage	Resistive load (A)	Inductive load (A) ($\text{COS } \varphi \geq 0.6, L/R \leq 0.007$)
100-250V AC	11	6
250V DC	0.3	0.3
125V DC	0.6	0.6
30V DC	6	5
8V DC	10	6

Note 1: When a Door interlock is specified, a storage draw-out handle is supplied.

Note 2: Door interlock can not be specified with Door flange.

Note 3: Contact FUJI for the details for fitting Door Interlock with IP55 cover.

■ Applicable maximum rated current by main circuit terminal connection

Type	Standard Direction	IEC, EN, AS, JIS			NEMA, ANSI		
		Vertical	Horizontal	Front	Vertical	Horizontal	Front
DH08		800A	800A	800A	800A	800A	800A
DH12		1250A	1250A	1250A	1250A	1250A	1250A
DH16		1600A	1600A	1600A	1600A	1540A	1570A
DH20		2000A	2000A	2000A	2000A	1670A	1830A
DH25		2500A	2430A	2500A	2500A	2230A	2430A
DH30		3200A	2790A	3150A	3200A	2700A	2890A
DH40		4000A	—	—	3700A	—	—
DH50		5000A	—	—	—	—	—
DH60		6300A	—	—	—	—	—
DH12H		1250A	1250A	—	1250A	1250A	—
DH16H		1600A	1600A	—	1600A	1540A	—
DH20H		2000A	2000A	—	2000A	1670A	—
DH16P		1600A	1600A	—	1600A	1600A	—
DH20P		2000A	2000A	—	2000A	2000A	—
DH25P		2500A	2430A	—	2500A	2230A	—
DH30P		3200A	2790A	—	3200A	2700A	—

■ : Standard terminal connection

■ Dielectric strength

Circuit			Withstand voltage (at 50/60 Hz)		Rated Impulse withstand voltage U_{imp}
Main circuit			Between terminals, terminal group to earth	3500V AC for 1 minute	12kV
Control circuits	Auxiliary switches	For general service	Terminal group to earth	2500V AC for 1 minute	6kV
		For microload	Terminal group to earth	2000V AC for 1 minute	4kV
	Position switches		Terminal group to earth	2000V AC for 1 minute	4kV
	Over-current release (OCR)		Terminal group to earth	2000V AC for 1 minute	4kV
	Power supply for undervoltage/reverse power trip function		Terminal group to earth	2500V AC for 1 minute	6kV
Other accessories			Terminal group to earth	2000V AC for 1 minute	4kV

Note: The values shown above are those measured on phase connections and cannot be applied to control terminals on the ACB.

■ Internal resistance and power consumption

• Standard types

Type	DH08	DH12	DH16	DH20	DH25	DH30	DH40	DH50	DH60
Rated current (A)	800	1250	1600	2000	2500	3200	4000	5000	6300
DC internal resistance per pole (m)	0.033	0.033	0.028	0.024	0.014	0.014	0.014	0.012	0.010
AC power consumption for 3 poles (W)	200	350	350	490	600	780	1060	1620	1910

• High breaking types

Type	DH12-H	DH16-H	DH20-H	DH16-P	DH20-P	DH25-P	DH30-P
Rated current (A)	1250	1600	2000	1600	2000	2500	3200
DC internal resistance per pole (m)	0.024	0.024	0.024	0.014	0.014	0.014	0.014
AC power consumption for 3 poles (W)	260	350	490	310	430	600	780

Air Circuit Breakers

DH series

■ Derating

• Standard types

Based Standards	Ambient temperature (°C)	Type Connecting bar sizes	DH08 2x50x5t	DH12 2x80x5t	DH16 2x100x5t	DH20 3x100x5t	DH25 2x100x10t	DH30 3x100x10t	DH40 4x150x6t	DH50 3x200x10t	DH60 4x200x10t
IEC60947-2 EN 60947-2 AS3947.2 JIS C8201-2-1	40 (Standard ambient temperature)		800	1250	1600	2000	2500	3200	4000	5000	6300
	45		800	1250	1600	2000	2500	3200	4000	5000	6300
	50		800	1250	1600	1900	2500	3130	4000	4950	6000
	55		800	1200	1540	1820	2500	2990	3940	4710	5680
	60		800	1150	1460	1740	2400	2850	3760	4450	5370
NEMA, SG-3 ANSI C37.13	40 (Standard ambient temperature)		800	1250	1540	2000	2500	3200	3700	—	—
	45		800	1190	1470	1960	2500	3010	3580	—	—
	50		800	1130	1390	1860	2440	2860	3470	—	—
	55		790	1070	1310	1750	2300	2690	3350	—	—
	60		740	1000	1230	1640	2150	2520	3140	—	—

Note: The values are applicable for both Draw-out type and Fixed type.
The values of DH08 to DH16 are for horizontal terminals on both line and load side.
The values of DH20 to DH40 are for vertical terminals on both line and load side.
Above figures are subject to the design of the enclosure and rating of busbar.

• High breaking types

Based Standards	Ambient temperature (°C)	Type Connecting bar sizes	DH12-H 2x80x5t	DH16-H 2x100x5t	DH20-H 3x100x5t	DH16-P 2x100x5t	DH20-P 3x100x5t	DH25-P 2x100x10t	DH30-P 3x100x10t
IEC60947-2 EN 60947-2 AS3947.2	40 (Standard ambient temperature)		1250	1600	2000	1600	2000	2500	3200
	45		1250	1600	2000	1600	2000	2500	3200
	50		1250	1600	1900	1600	2000	2500	3200
	55		1250	1600	1820	1600	2000	2500	2990
	60		1250	1550	1740	1600	2000	2400	2850
NEMA, SG-3 ANSI C37.13	40 (Standard ambient temperature)		*	1600	2000	*	*	2500	3200
	45		*	1600	1960	*	*	2500	3010
	50		*	1600	1860	*	*	2440	2860
	55		*	1510	1750	*	*	2300	2690
	60		*	1420	1640	*	*	2150	2520

Note: The values are for vertical terminals on both line and load side.
Above figures are subject to the design of the enclosure and rating of busbar.
* Contact FUJI for details.

■ Operation Environments and recommendation for busbars connection

• Standard environment

The standard environment for ACBs is as follows:

Ambient temperature	–5°C to +40°C The average temperature for 24 hours must not exceed 35°C.
Relative humidity	45% to 85%
Attitude	Below 2000 m
Atmosphere	Excessive water vapor, oil vapor, smoke, dust, or corrosive gases must not exist. Sudden change in temperature, condensation, or icing must not occur.

• Special environment

Tropicalization (Fungus and moisture treatment)

Specify this treatment when the ACB is used under high-temperature and high-humidity conditions.

Conditions: Max. permissible ambient temperature 60°C
Max. permissible humidity 95% rel.
No condensation

Cold climate treatment

Specify this treatment when the ACB is used in cold areas.

Conditions: Min. permissible storage temperature –40°C
Min. permissible operating temperature –25°C
No condensation

Anti-corrosion treatment

Specify this treatment when the ACB is used in a corrosive atmosphere.

Contact FUJI for details.

■ Recommendation busbars connection

The busbars to the ACB should be firmly supported near the ACB terminal. Fault current flow through the busbars develops a large electromagnetic force between the busbars, and the support must be strong enough to withstand such forces. The ACB should not be relied on as a single support. The busbar support should be made of high quality insulator. Secure sufficient insulation distance (creeping distance above the busbar support, in particular).

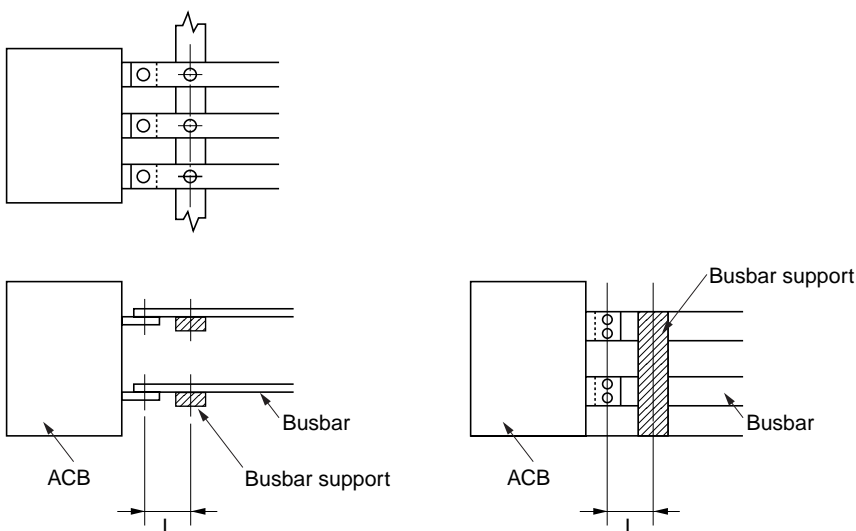

The maximum distance of the connection point of ACB to the first busbar support

Short-circuit current (kA)	30	50	65	80	100	120
Distance	Type DH08 to 20, DH12-H to 20-H					
L (mm)	300	250	150	150	–	–
	Type DH25 to 40, DH16-P to 30-P					
L (mm)	350	300	250	150	150	–
	Type DH50, DH60					
L (mm)	350	300	250	150	150	150

Air Circuit Breakers

DH series

■ Dimensions, mm

• Draw-out types

DH08, DH12, DH16, DH20

DH12-H, DH16-H, DH20-H

Terminal size

Type	t ₁	t ₂	t ₃	W
DH08	10	10	15	17.5
DH12	10	10	15	17.5
DH16	20	15	25	22.5
DH20	20	15	25	—
DH12-H	20	15	—	—
DH16-H	20	15	—	—
DH20-H	20	15	—	—

⊗ : Front panel center line

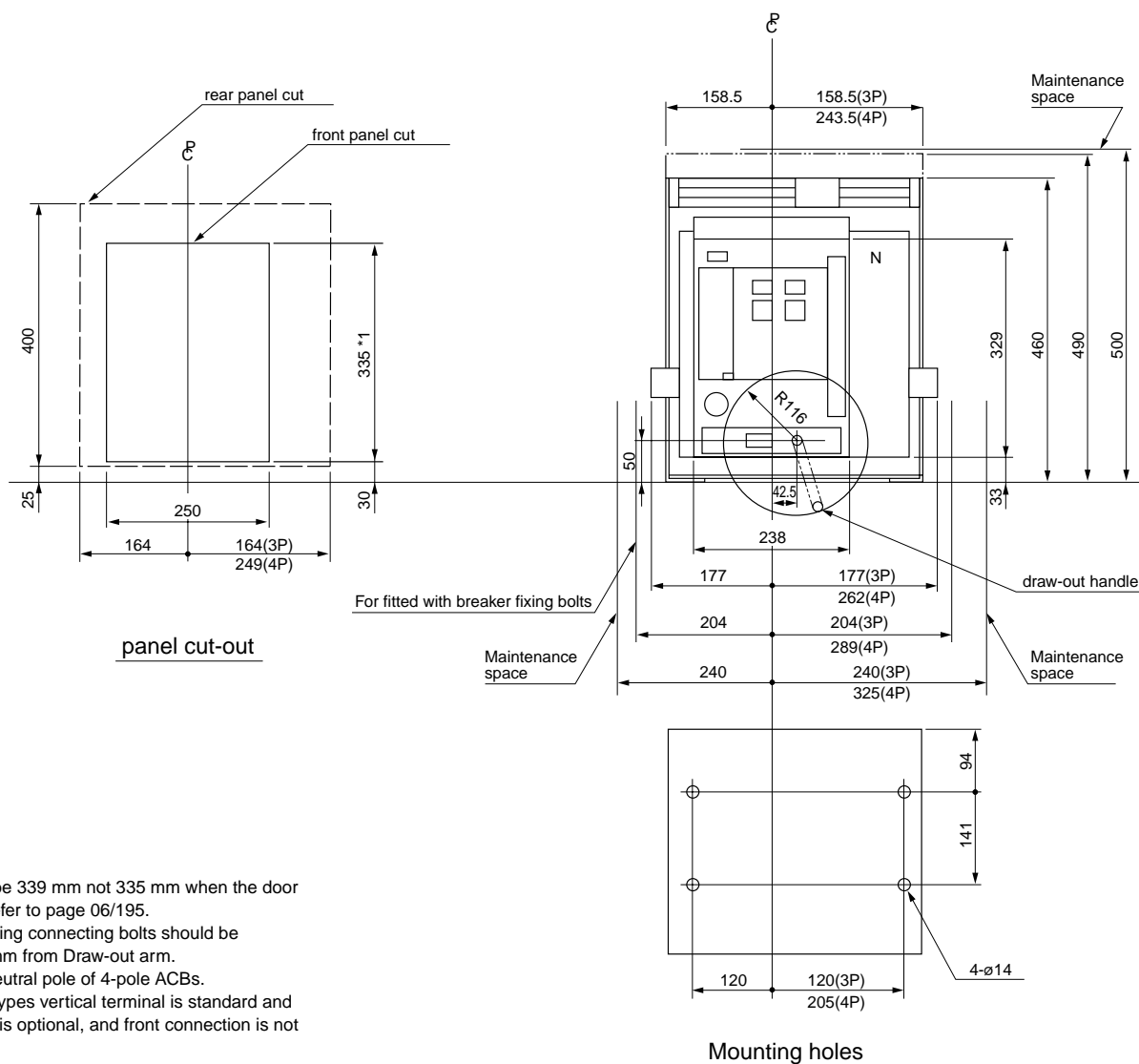

*1: Panel cut should be 339 mm not 335 mm when the door flange is used. Refer to page 06/195.

*2: Conductors including connecting bolts should be separated min-7mm from Draw-out arm.

- N represents the neutral pole of 4-pole ACBs.
- For High breaking types vertical terminal is standard and horizontal terminal is optional, and front connection is not available.

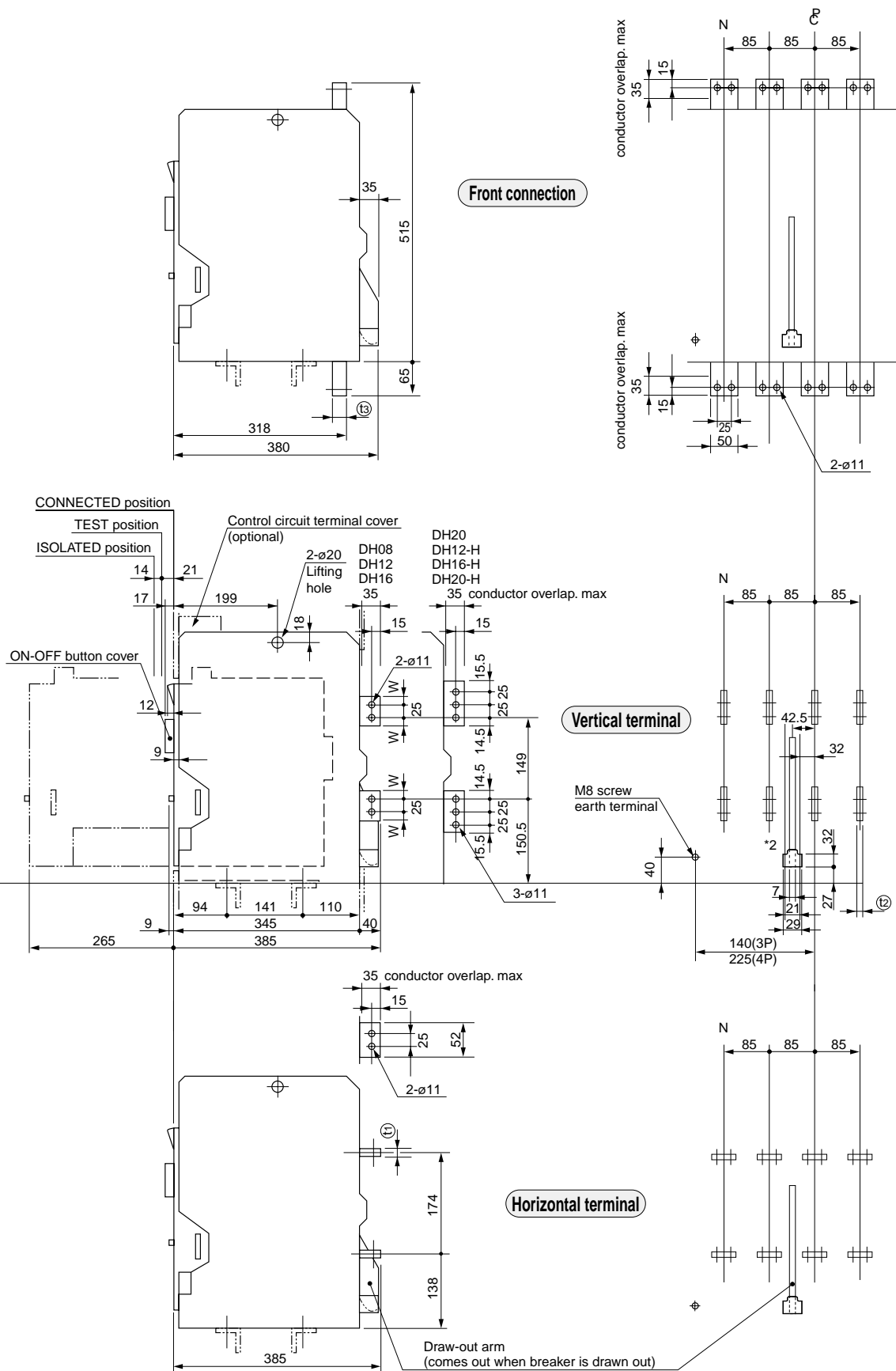

06

Air Circuit Breakers DH series

■ Dimensions, mm

• Fixed types

DH08, DH12, DH16, DH20

Terminal size

Type	t ₁	t ₂	t ₃	W
DH08	10	10	15	17.5
DH12	10	10	15	17.5
DH16	20	15	25	22.5
DH20	20	15	25	—

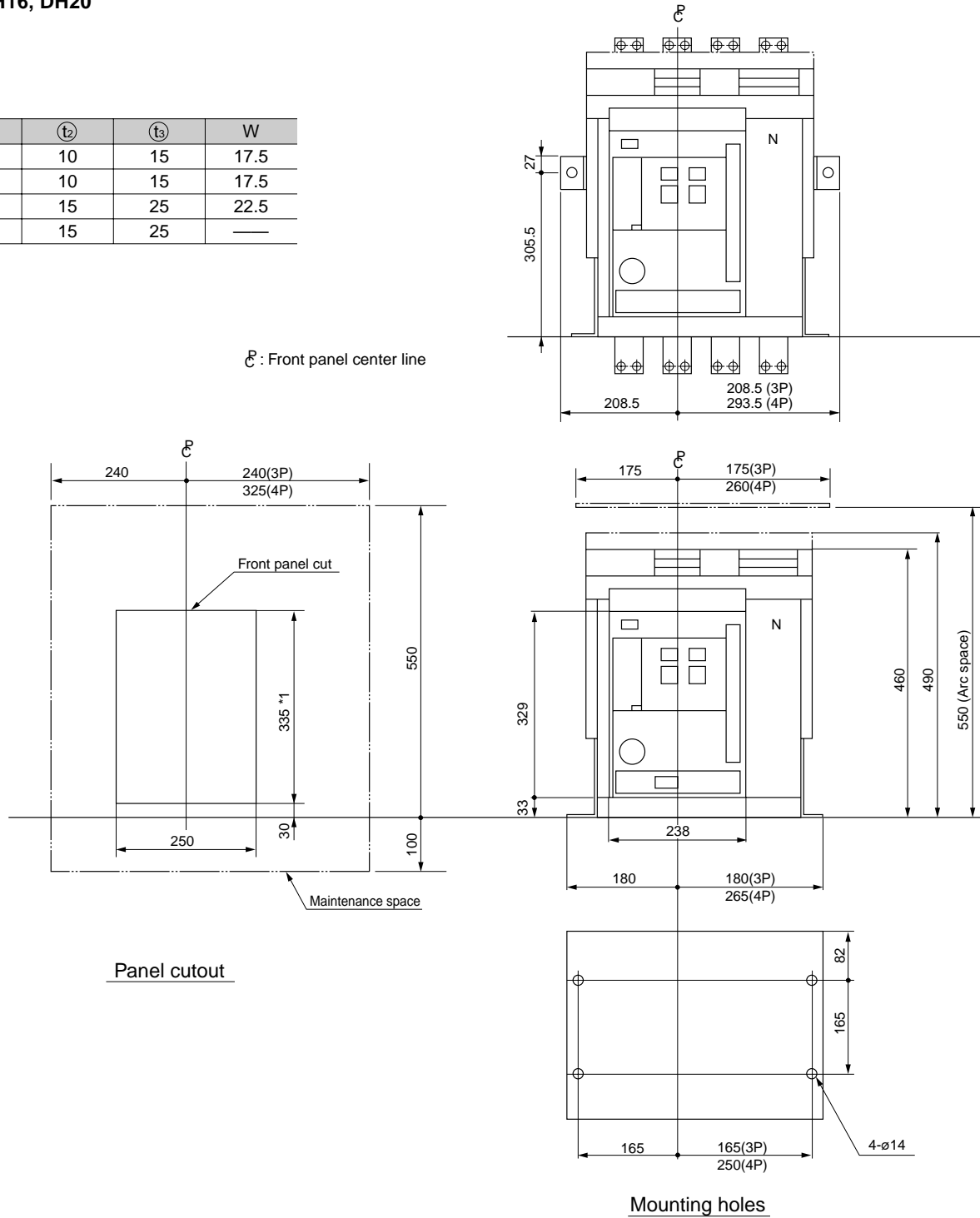

*1: Panel cut should be 339 mm not 335 mm when the door flange is used. Refer to page 06/195.

• N represents the neutral pole of 4-pole ACBs.

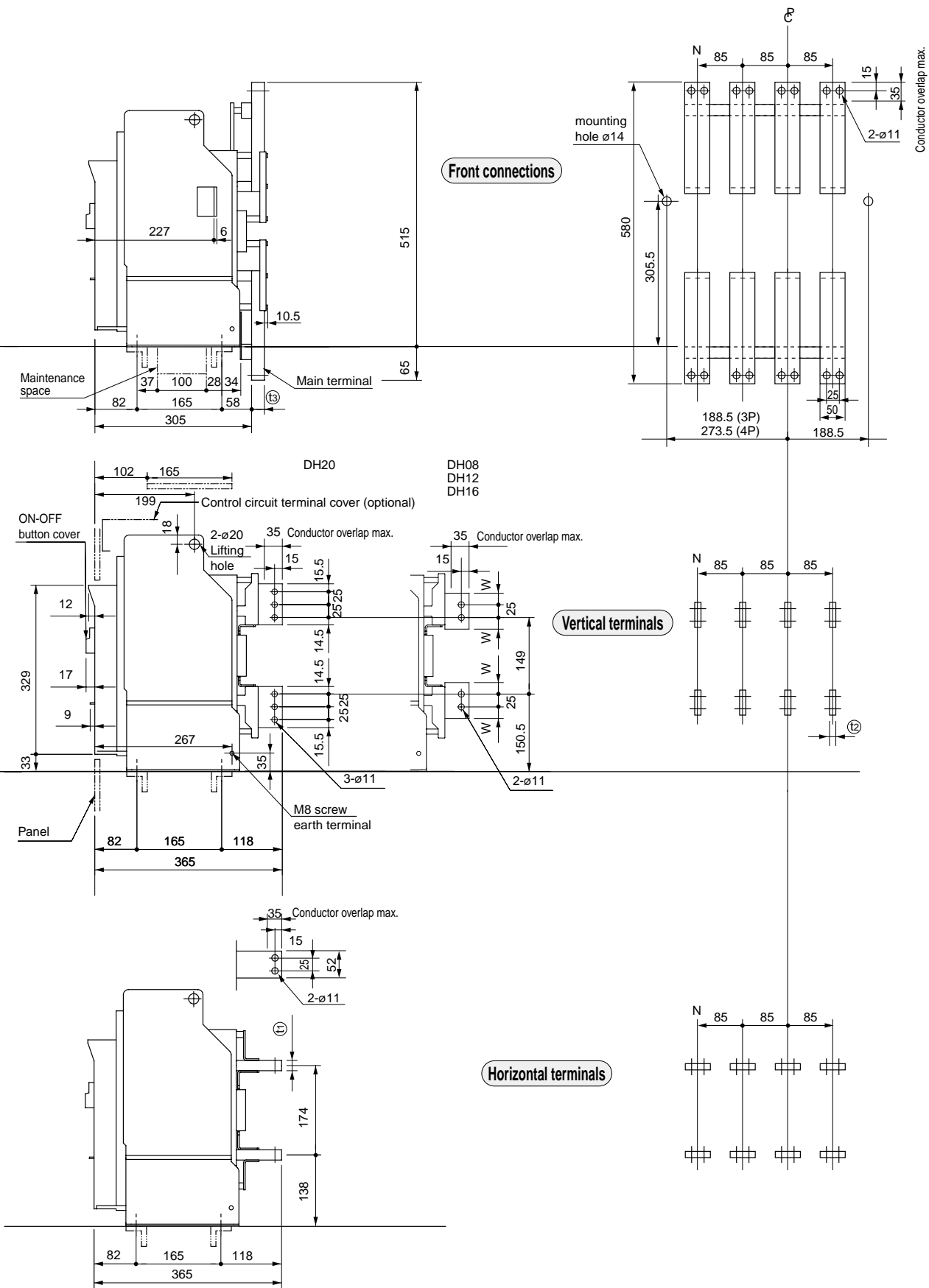

Air Circuit Breakers

DH series

■ Dimensions, mm

• Draw-out types

DH25, DH30

DH16-P, DH20-P, DH25-P, DH30-P

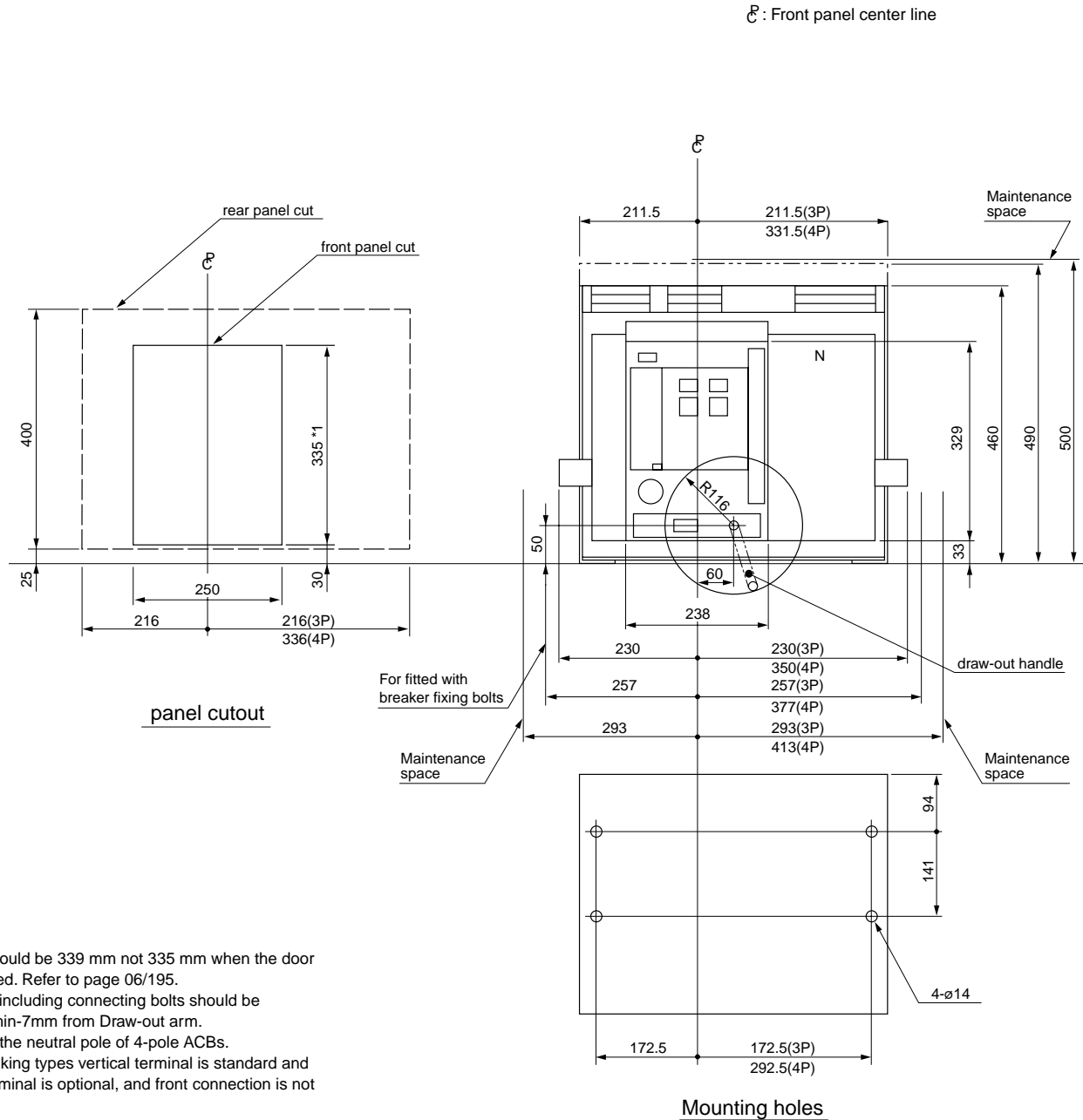

*1: Panel cut should be 339 mm not 335 mm when the door flange is used. Refer to page 06/195.

*2: Conductors including connecting bolts should be separated min-7mm from Draw-out arm.

- N represents the neutral pole of 4-pole ACBs.
- For High breaking types vertical terminal is standard and horizontal terminal is optional, and front connection is not available.

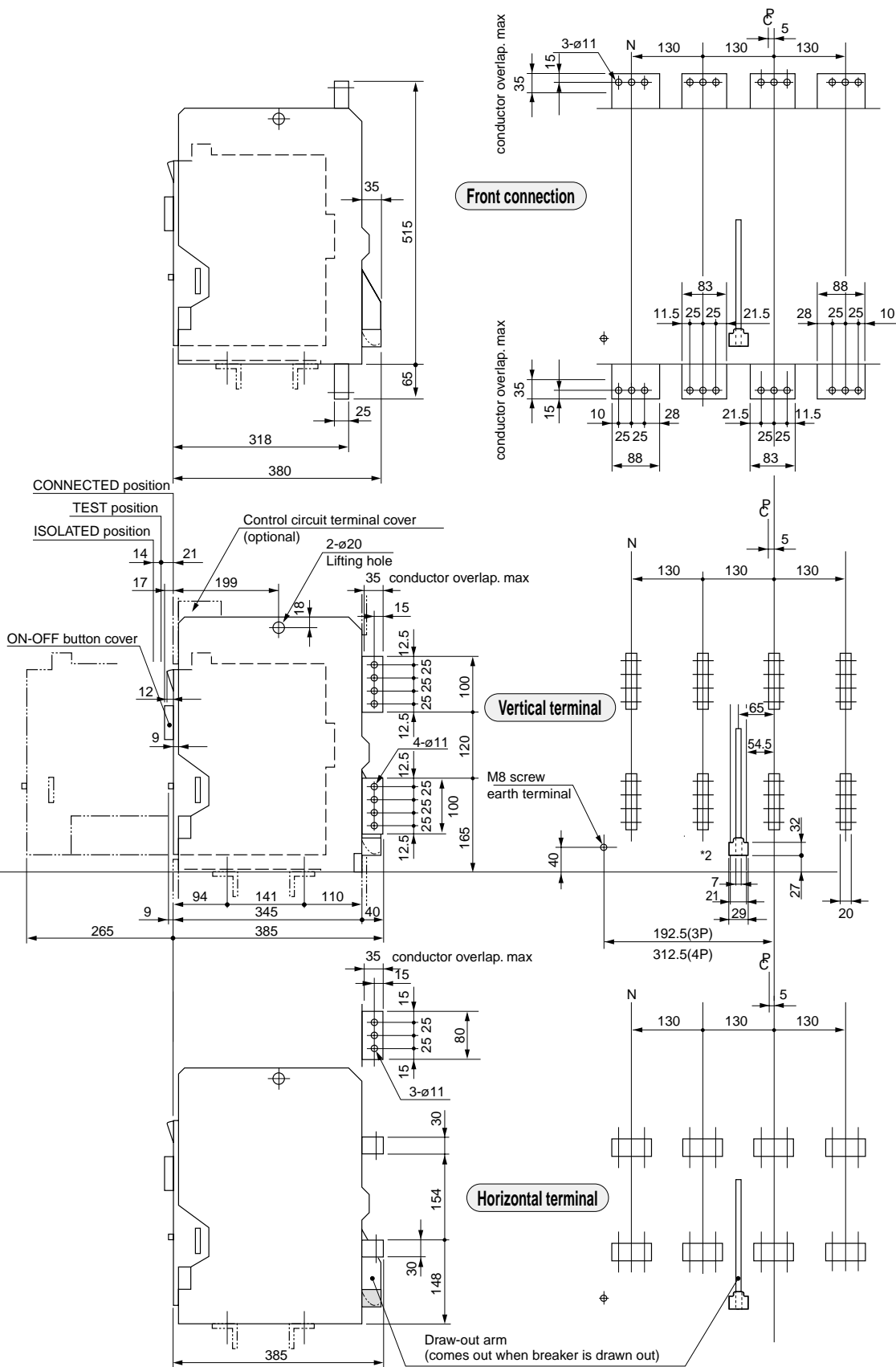

Air Circuit Breakers DH series

- Dimensions, mm
- Fixed types
DH25, DH30

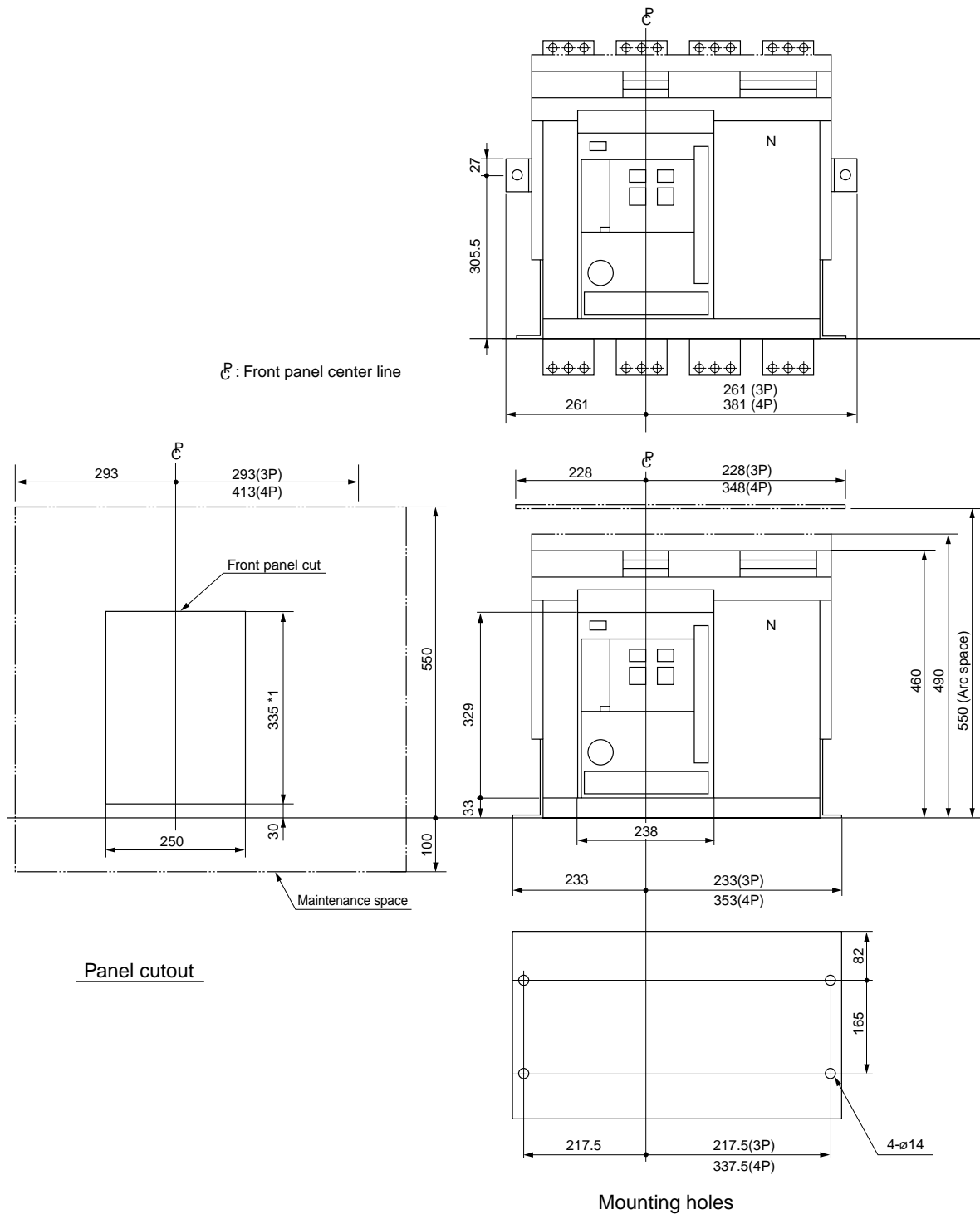

*1: Panel cut should be 339 mm not 335 mm when the door flange is used. Refer to page 06/195.

• N represents the neutral pole of 4-pole ACBs.

Air Circuit Breakers DH series

- Dimensions, mm
- Drow-out types
DH40

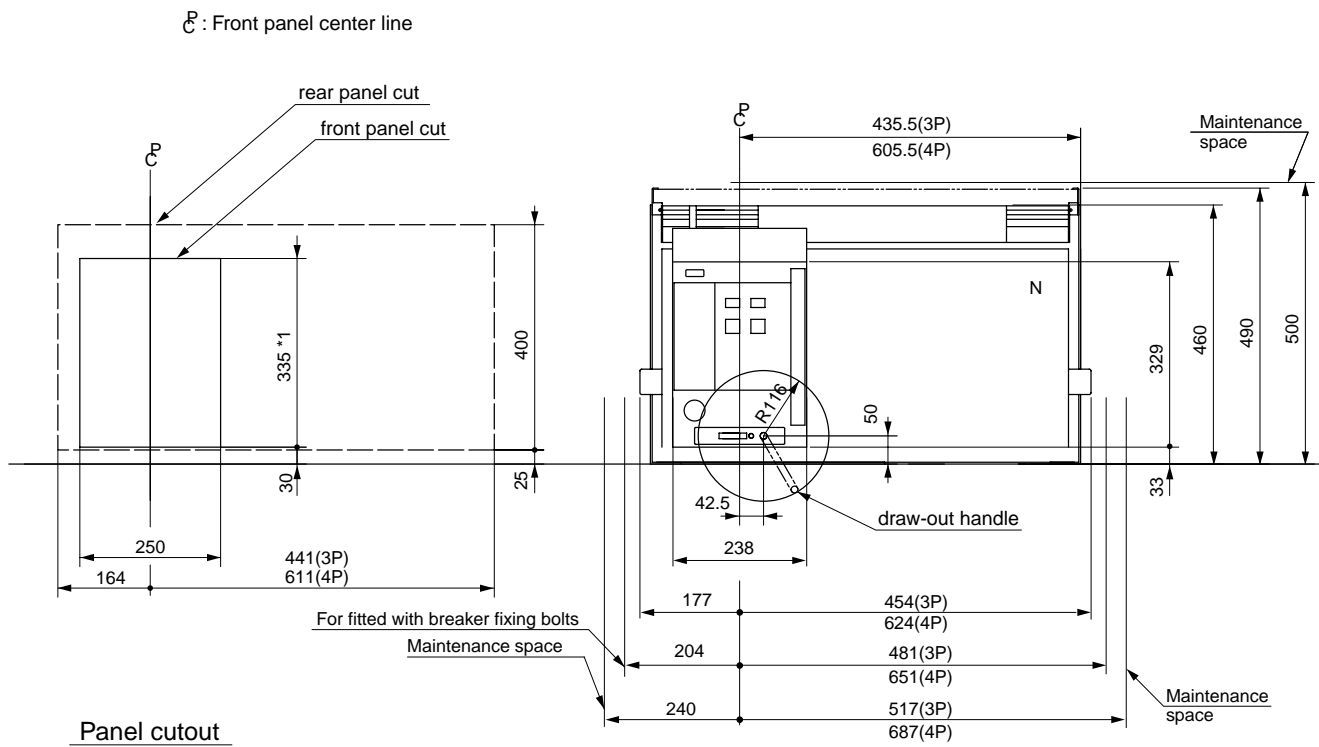

*1: Panel cut should be 339 mm not 335 mm when the door flange is used. Refer to page 06/195.

*2: Conductors including connecting bolts should be separated min-7mm from Draw-out arm.

• N represents the neutral pole of 4-pole ACBs.

Air Circuit Breakers DH series

- Dimensions, mm
- Draw-out types
DH50, DH60

CP: Front panel center line

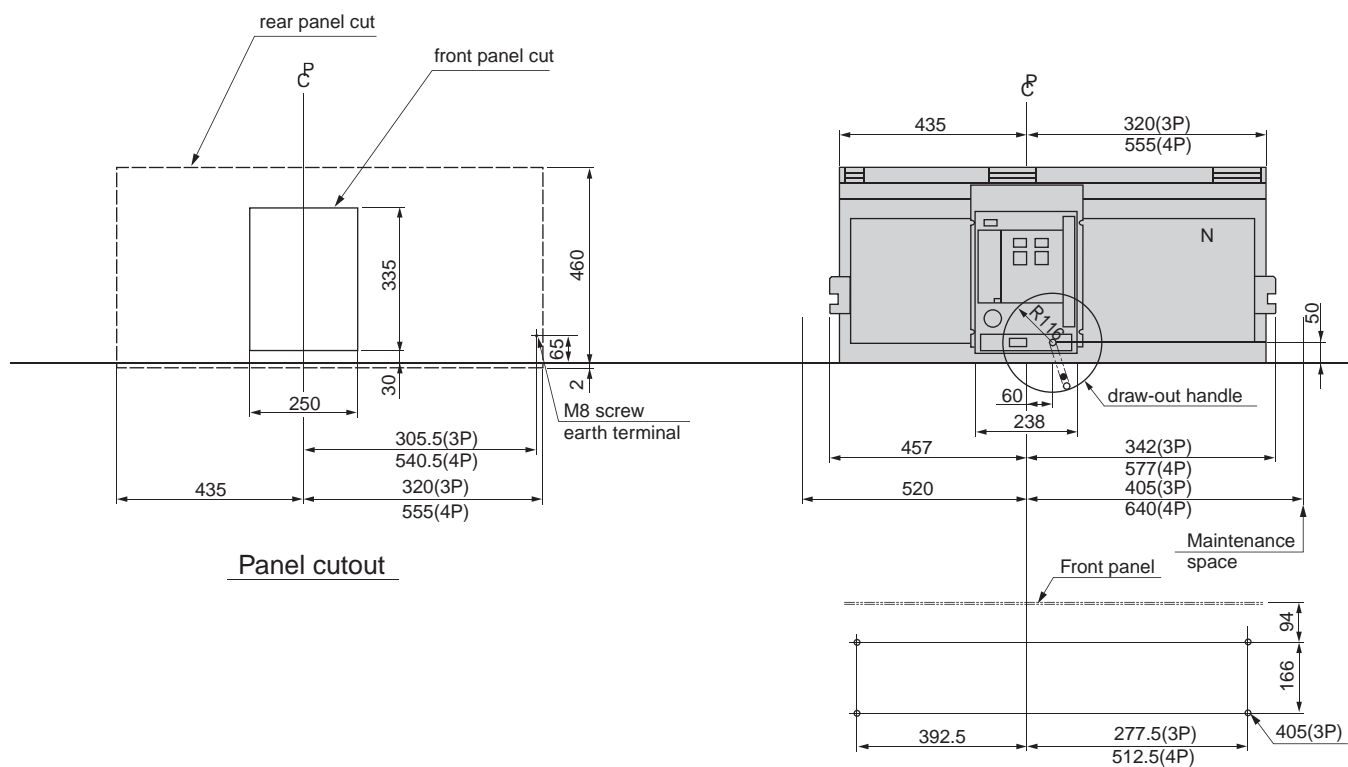

• N represents the neutral pole of 4-pole ACBs.

Air Circuit Breakers DH series

■ Wiring diagrams (With AGR-11B OCR)

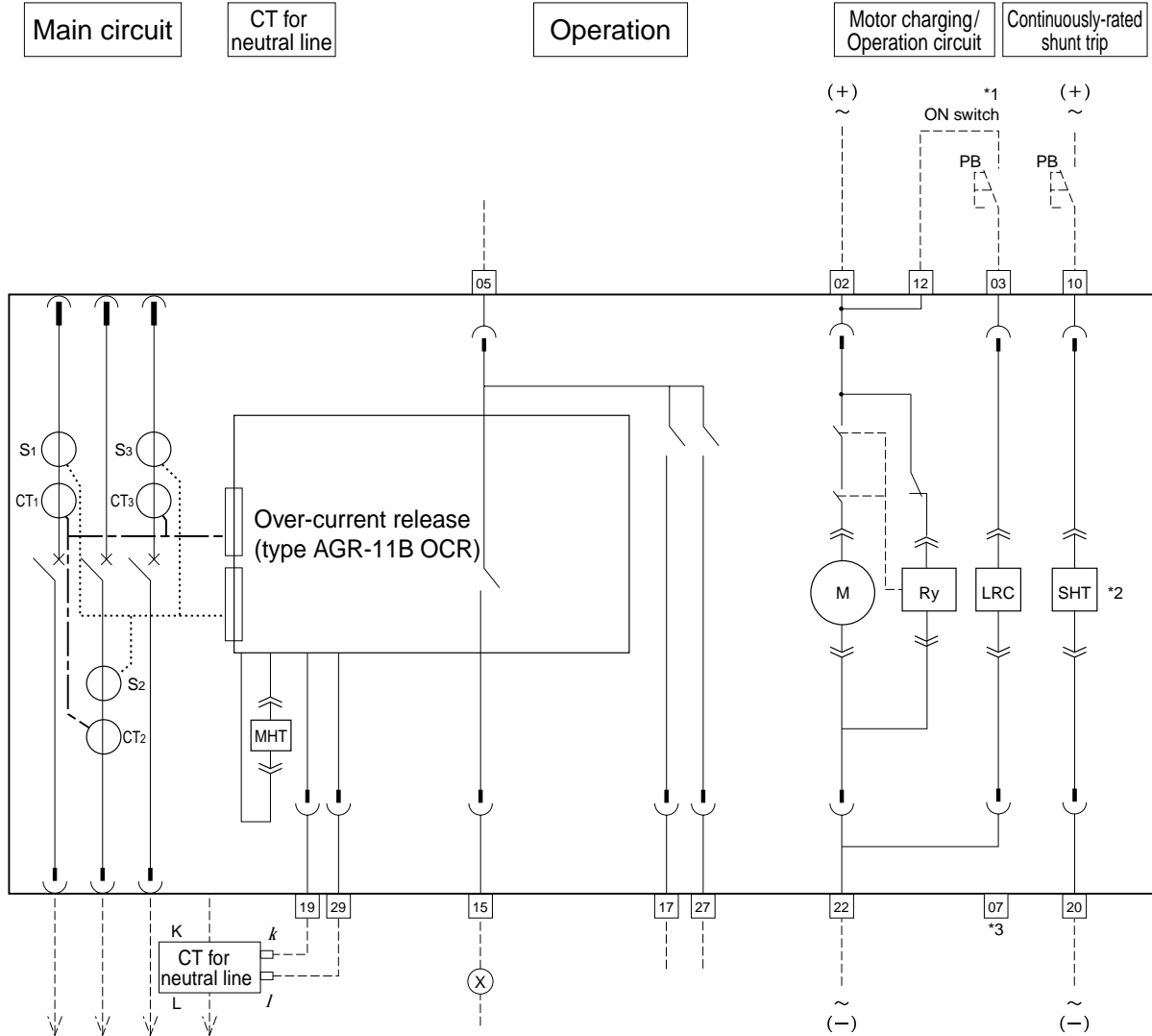

Terminal description

Check OCR voltage before connecting.

- 02/22 Control power supply 100-240V AC, 100-250V DC, 24V DC, 48V DC
- 12 Operation switch, common
- 03 ON switch
- 05 Operation indication terminal, common
- 15 Single-contact indication
- 17 Trip indication
- 27 Spring charge indicator
- 10/20 Continuously-rated shunt trip
- 19 Separate CT for neutral line (K)
- 29 Separate CT for neutral line (I)
- 08/18/28 UVT power supply
- 09 UVT power supply common

UVT power supply

Term. No.	AC 100V unit	AC 200V unit	AC 400V unit
08-09	100V	200V	380V
18-09	110V	220V	415V
28-09	120V	240V	440V

Symbols for accessories

- CT1 - CT3 : Power CTs
- S1 - S3 : Current sensors
- M : Charging motor
- LRC : Latch release coil
- MHT : Magnetic Hold Trigger
- ← Isolating terminal connector (for draw-out type)
- ⌞ Manual connector
- User wiring
- (X)-- Relay or indicator lamp

*1: Do not connect "b" contact of auxiliary switch to ON switch in series, otherwise, pumping may occur.

*2: See page 06/177 for the circuit diagram of the continuously-rated shunt trip device with capacitor trip device.

*3: For motor split circuit, terminals 02, 22 and 03, 07 are used for charging and closing operation respectively. (Please specify when ordering)

*4: Refer to page 06/178 (short pulse only)

Undervoltage trip
Position switches
Auxiliary switches

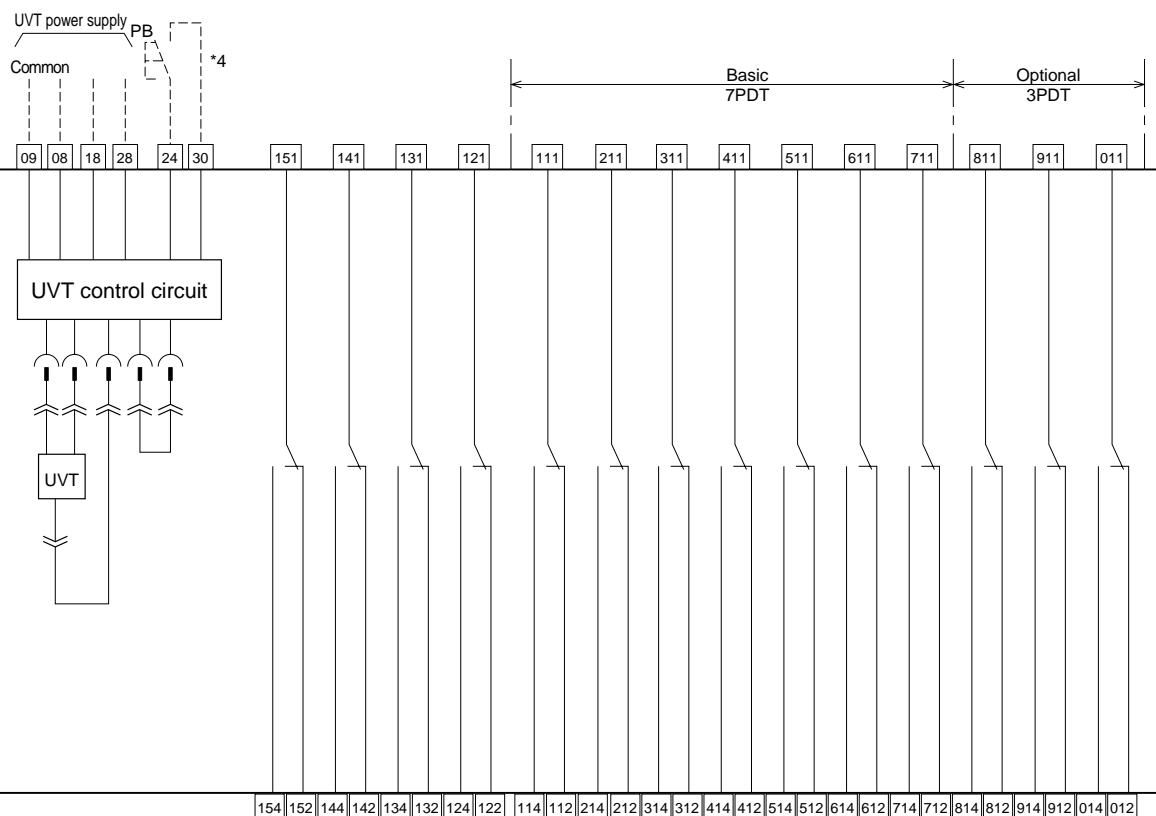

Designation of terminals for auxiliary and position switches

* * *
 1: Common
 2: b-contact
 4: a-contact

1: Auxiliary switch
 2: Position switch (for CONNECTED)
 3: Position switch (for TEST)
 4: Position switch (for ISOLATED)
 5: Position switch (for INSERT)

(1 - 0: Switch numbers
 A, B, C: Auxiliary switches for microload

CONNECTED position : 121-124 ON
 121-122 OFF
 TEST position : 131-134 ON
 131-132 OFF
 ISOLATED position : 141-144 ON
 141-142 OFF
 INSERT position : 151-154 ON
 151-152 OFF

For operation sequence of position switches, see page 06/198.

Position switches

Top	151	141	131	121
Middle	154	144	134	124
Bottom	152	142	132	122

Top	131	121
Middle	134	124
Bottom	132	122

Operation/control circuits

01	02	03	04	05	06	07	08	09	10
11	12	13	14	15	16	17	18	19	20
21	22	23	24	25	26	27	28	29	30

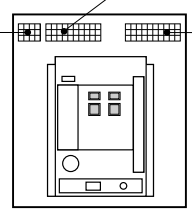

Auxiliary switches

(Standard 7PDT + optional 3PDT arrangement)

111	211	311	411	511	611	711	811	911	011
114	214	314	414	514	614	714	814	914	014
112	212	312	412	512	612	712	812	912	012

(Standard 7PDT arrangement)

111	211	311	411	511	611	711
114	214	314	414	514	614	714
112	212	312	412	512	612	712

Air Circuit Breakers DH series

■ Wiring diagrams (With AGR-21B OCR)

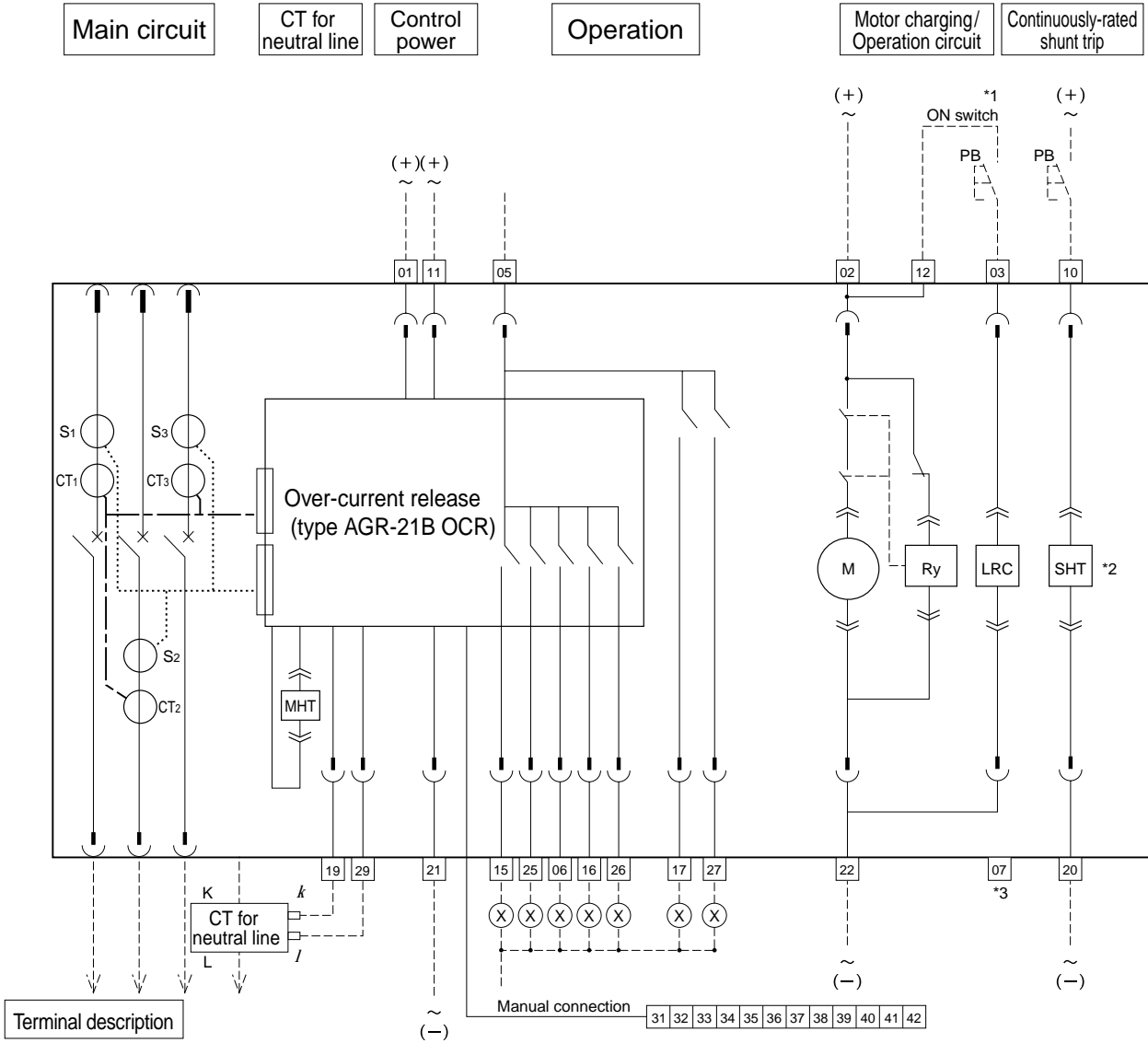

Terminal description

- Check OCR voltage before connecting.
- 01|21 Control power supply 200 - 240V AC, 200 - 250V DC, 48V DC
 - 01|11 Control power supply 100 - 120V AC
 - 11|21 Control power supply 100 - 125V AC, 24V DC
 - 02|22 Control power supply 100 - 240V AC, 100 - 250V DC, 24V DC, 48V DC
 - 12 Operation switch, common
 - 03 ON switch
 - 05 Operation indication terminal, common
 - 15 LT trip indication
 - 25 ST, INST trip indication
 - 06 PTA indication
 - 16 GF trip indication
 - 26 System alarm indication
 - 17 REF, NS or trip indication
 - 27 PTA2, UV or spring charge indication
 - 10|20 Continuously-rated shunt trip
 - 19 Separate CT for neutral line (k)
 - 29 Separate CT for neutral line (l)
 - 08|18|28 UVT power supply
 - 09 UVT power supply common
 - 35 Separate CT for REF (k)
 - 36 Separate CT for REF (l)
 - 41|42 Communication line

UVT power supply

Term. No.	100V AC unit	200V AC unit	400V AC unit
08 - 09	100V	200V	380V
18 - 09	110V	220V	415V
28 - 09	120V	240V	440V

Symbols for accessories

- CT1 - CT3 : Power CTs
- S1 - S3 : Current sensors
- M : Charging motor
- LRC : Latch release coil
- MHT : Magnetic Hold Trigger
- ⊖ Isolating terminal connector (for draw-out type)
- ⊖ Manual connector
- User wiring
- ⊖⊖ Relay or indicator lamp

*1: Do not connect "b" contact of auxiliary switch to ON switch in series, otherwise, pumping may occur.
 *2: See page 06/177 for the circuit diagram of the continuously-rated shunt trip device with capacitor trip device.
 *3: For motor split circuit, terminals 02, 22 and 03, 07 are used for charging and closing operation respectively. (Please specify when ordering)
 *4: Refer to page 06/178 (short pulse only)

Undervoltage trip Position switches Auxiliary switches

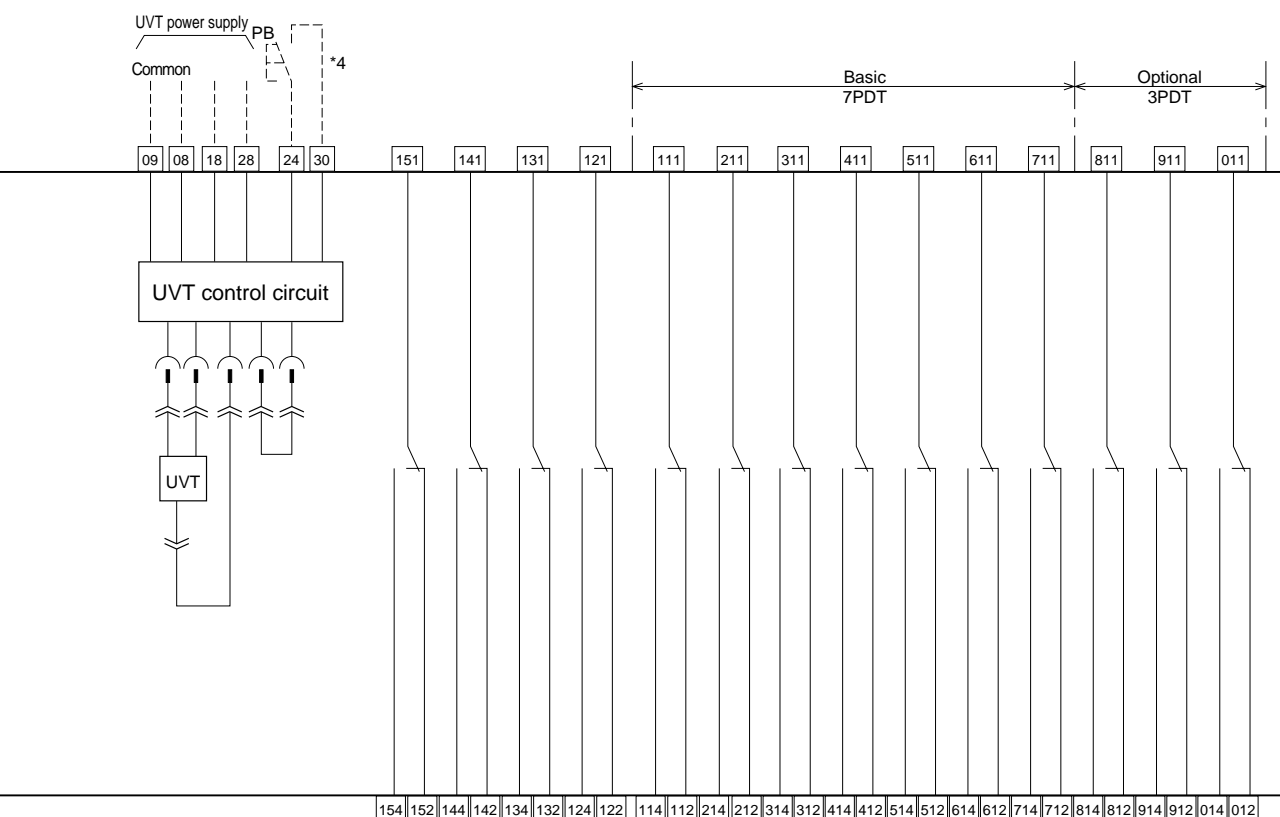

06

Designation of terminals for auxiliary and position switches

1: Common
2: b-contact
4: a-contact

1: Auxiliary switch
2: Position switch (for CONNECTED)
3: Position switch (for TEST)
4: Position switch (for ISOLATED)
5: Position switch (for INSERT)

(1 - 0: Switch numbers
A, B, C: Auxiliary switches for microload)

CONNECTED position : 121-124 ON
121-122 OFF

TEST position : 131-134 ON
131-132 OFF

ISOLATED position : 141-144 ON
141-142 OFF

INSERT position : 151-154 ON
151-152 OFF

For operation sequence of position switches, see page 06/198.

Position switches

Top	151	141	131	121
Middle	154	144	134	124
Bottom	152	142	132	122

Top	131	121
Middle	134	124
Bottom	132	122

Operation/control circuits

01	02	03	04	05	06	07	08	09	10
11	12	13	14	15	16	17	18	19	20
21	22	23	24	25	26	27	28	29	30

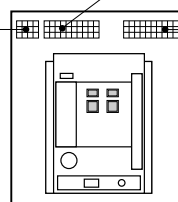

Auxiliary switches

(Standard 7PDT + optional 3PDT arrangement)

111	211	311	411	511	611	711	811	911	011
114	214	314	414	514	614	714	814	914	014
112	212	312	412	512	612	712	812	912	012

(Standard 7PDT arrangement)

111	211	311	411	511	611	711
114	214	314	414	514	614	714
112	212	312	412	512	612	712

31 32 33 34 35 36 37 38 39 40 41 42 Manual connection

If the ground fault protection on the line side or communication function is incorporated, control circuit terminals are of manual connection type.

Air Circuit Breakers DH series

■ Wiring diagrams (With AGR-22B, 31B OCR)

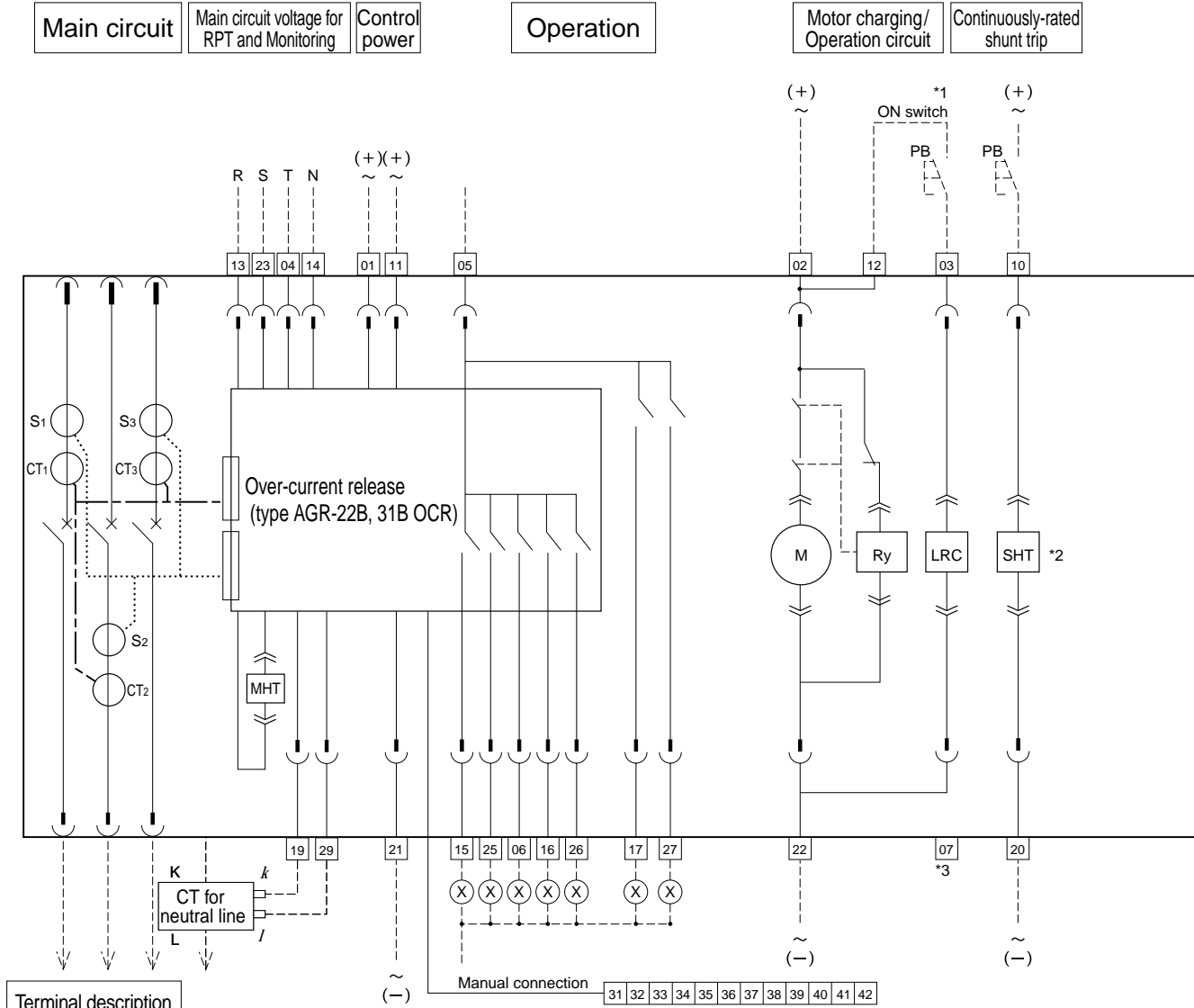

Terminal description

- Check OCR voltage before connecting.
- 01|21 Control power supply 200 - 240V AC, 200 - 250V DC, 48V DC
 - 01|11 Control power supply 100 - 120V AC
 - 11|21 Control power supply 100 - 125V AC, 24V DC
 - 02|22 Control power supply 100 - 240V AC, 100 - 250V DC, 24V DC, 48VDC
 - 12 Operation switch, common
 - 03 ON switch
 - 05 Operation indication terminal, common
 - 15 LT trip indication
 - 25 ST, INST trip indication
 - 06 PTA indication
 - 16 GF trip indication
 - 26 System alarm indication
 - 17 REF, NS or trip indication
 - 27 PTA2, UV or spring charge indication
 - 10|20 Continuously-rated shunt trip
 - 19 Separate CT for neutral line (k)
 - 29 Separate CT for neutral line (l)
 - 08|18|28 UVT power supply
 - 09 UVT power supply common
 - 35 Separate CT for REF (k)
 - 36 Separate CT for REF (l)
 - 41|42 Communication line

UVT power supply

Term. No.	100V AC unit	200V AC unit	400V AC unit
08 - 09	100V	200V	380V
18 - 09	110V	220V	415V
28 - 09	120V	240V	440V

Symbols for accessories

- CT1 - CT3 : Power CTs
- S1 - S3 : Current sensors
- M : Charging motor
- LRC : Latch release coil
- MHT : Magnetic Hold Trigger
- ⊖ Isolating terminal connector (for draw-out type)
- ⊖ Manual connector
- User wiring
- ⊖⊖ Relay or indicator lamp

*1: Do not connect "b" contact of auxiliary switch to ON switch in series, otherwise, pumping may occur.
 *2: See page 06/177 for the circuit diagram of the continuously-rated shunt trip device with capacitor trip device.
 *3: For motor split circuit, terminals 02, 22 and 03, 07 are used for charging and closing operation respectively. (Please specify when ordering)
 *4: Refer to page 06/178 (short pulse only)

Undervoltage trip
Position switches
Auxiliary switches

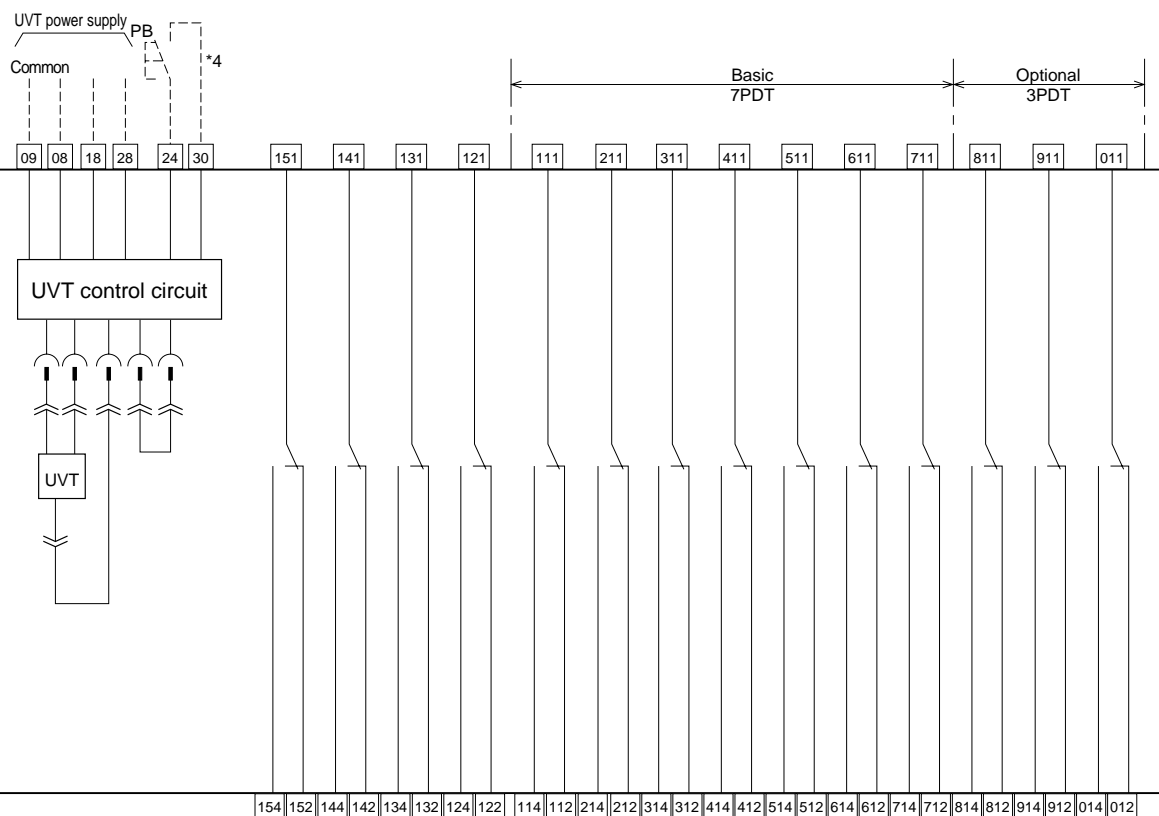

06

Designation of terminals for auxiliary and position switches

* 1: Common
 2: b-contact
 4: a-contact

1: Auxiliary switch
 2: Position switch (for CONNECTED)
 3: Position switch (for TEST)
 4: Position switch (for ISOLATED)
 5: Position switch (for INSERT)

(1 - 0: Switch numbers
 A, B, C: Auxiliary switches for microload

CONNECTED position : 121-124 ON
 121-122 OFF
 TEST position : 131-134 ON
 131-132 OFF
 ISOLATED position : 141-144 ON
 141-142 OFF
 INSERT position : 151-154 ON
 151-152 OFF

For operation sequence of position switches, see page 06/198.

Position switches

Top	151	141	131	121
Middle	154	144	134	124
Bottom	152	142	132	122

Top	131	121
Middle	134	124
Bottom	132	122

Operation/control circuits

01	02	03	04	05	06	07	08	09	10
11	12	13	14	15	16	17	18	19	20
21	22	23	24	25	26	27	28	29	30

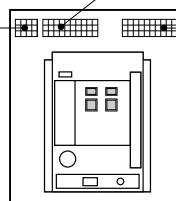

Auxiliary switches

(Standard 7PDT + optional 3PDT arrangement)

111	211	311	411	511	611	711	811	911	011
114	214	314	414	514	614	714	814	914	014
112	212	312	412	512	612	712	812	912	012

(Standard 7PDT arrangement)

111	211	311	411	511	611	711
114	214	314	414	514	614	714
112	212	312	412	512	612	712

31 32 33 34 35 36 37 38 39 40 41 42 Manual connection

If the ground fault protection is incorporated and a separate current transformer for neutral line is used, or any one of ground fault protection on the line side, zone interlock, external display or communication function is incorporated, control circuit terminals are of manual connection type.