

# Power Monitoring Equipment General Information

## Power monitoring equipment (F-MPC) F-MPC60B, F-MPC30, F-MPC04 series

### ■ Description

- FUJI power monitoring equipment (F-MPC) realizes fine power management to contribute to energy-saving.
- We can offer you various F-MPC equipment such as F-MPC04 series power monitoring unit that measures electric power of one to multi-circuits, and compact size F-MPC60B, F-MPC30 series multifunctional digital relay that protects, controls, and measures high-voltage distribution facilities.
- As support tool, a power monitoring system software, F-MPC-Net is also available, which collects and analyzes data measured by F-MPC.
- As related products of F-MPC, molded case circuit breaker with ZCT and split type current transformer are introduced.

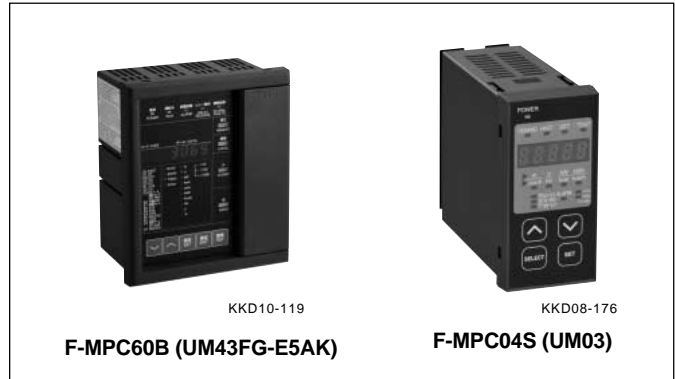

### ■ Power monitoring equipment used in power distribution system

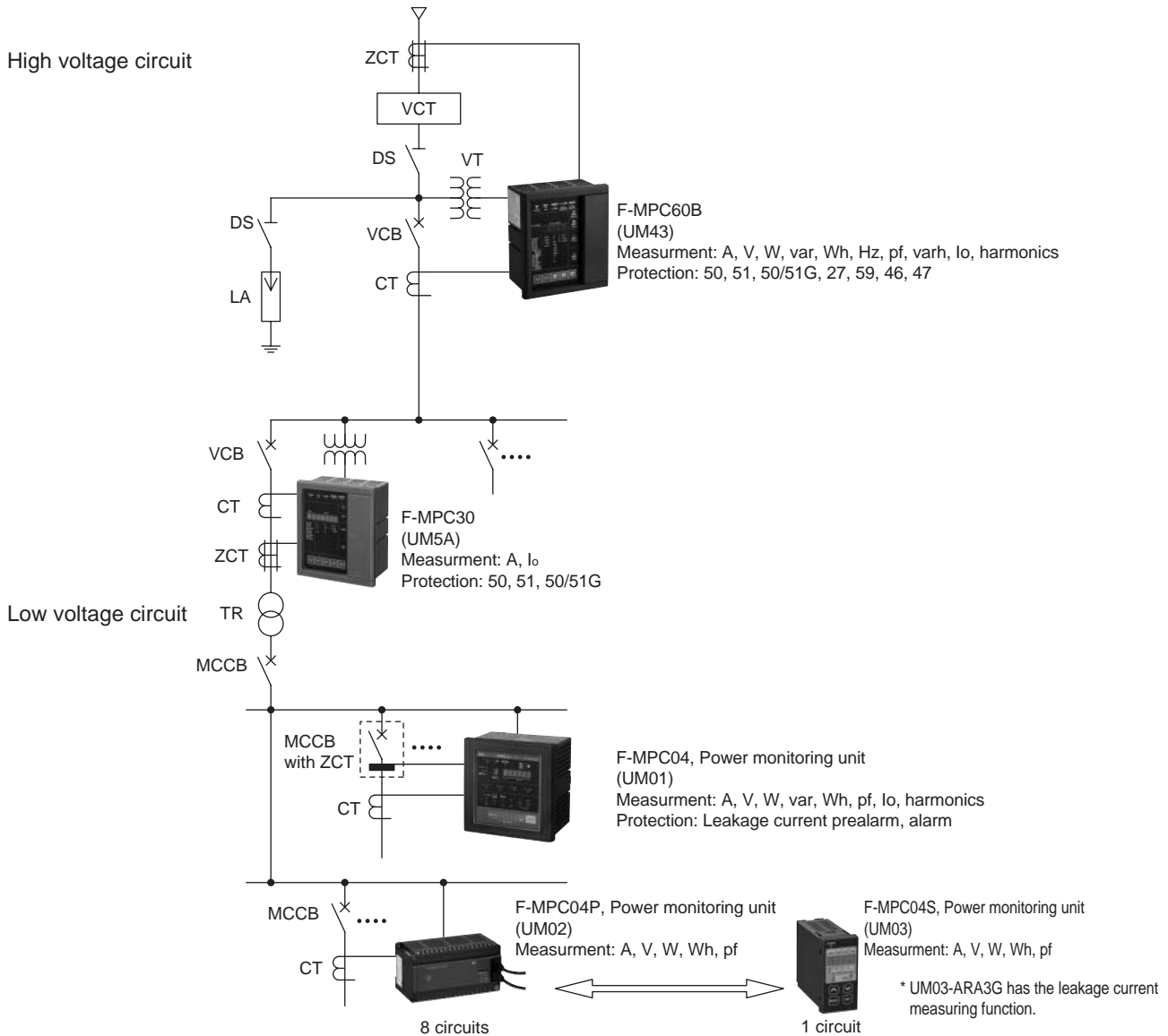

**Multiple function protectors and controllers**  
**F-MPC60B, F-MPC30 series**

■ **Description**

- FUJI multiple function protector and controller (F-MPC) performs energy control to contribute to energy-saving. The F-MPC60B and F-MPC30 are a kind of multifunctional digital relays.
- Although these series are very compact, they integrate multiple functions in a compact body, such as protection, measurement, operation, and monitoring of high-voltage power distribution and switching facilities. They can also transmit data obtained from these functions to upper level controllers.

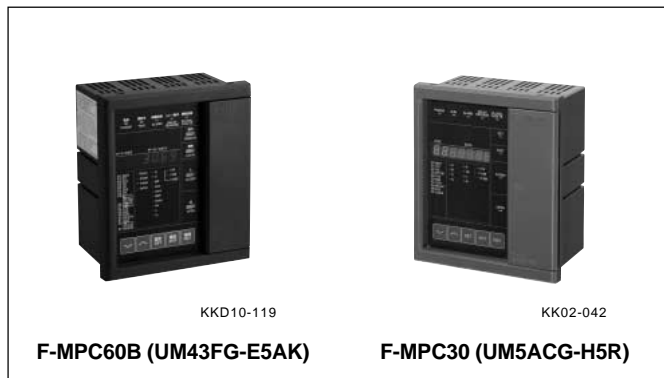

■ **Functions**

The functions of F-MPC60B and F-MPC30 series are listed below.

Series		F-MPC60B	F-MPC30
Type		<b>UM43FG-E5AK</b>	<b>UM5ACG-H5R</b>
Installation location		Receiving or feeder	Feeder
Application (phase: line)		3:3, 3:4	3:3, 3:4
VT voltage	Input	2VT/3VT star	—
	Voltage indication	Between phases, between lines	—
Ground fault system	System type	Direct/resistance	Direct/resistance
IO detection	①Residual (3XCT)	○	○
	②Tertiary winding (100/5A)	○	○
	③ZCT (5 to 100/5A)	○	○
	④ZCT (5 to 400/5A)	○	○
	⑤ZCT (200/1.5mA)	—	—
	⑥ZCT (100/1A) or (70/1A) or secondary I input (0.002 to 0.4A)	—	—
E0 detection * Feeder: Depending on MN signal.	EVT (3Ry= 110V)	—	—
	EVT (3Ry= 190V)	—	—
	ZPD-1 (FUJI-made)	—	—
	MN signal output	—	—
	MN signal input	—	—
Protective characteristic (current)	SI, VI, LT, EI, I <sup>2</sup> t	○	○ (without I <sup>2</sup> t)
	DT1 (short-time)	○	○
	DT2 (definite-time)	○	○
Control voltage	Rating	100V DC	100/200V DC
	Allowable range	80 to 143V DC	80 to 286V DC
Transducer output selection	No. of output pole	6	—
	(Function and terminal)	Select	—
No. of DI/DO		8 : 8	1 : 3
No. of CPU		2	1
External plug		—	○
CB close/open	CB making slow-down monitoring function	○	—
	Harmonic voltage (3, 5, 7, Total)	—	—
	Harmonic current (3, 5, 7, Total)	○	—
	Demand current	○	—
Display mode	All or part: changeable	○	— (All only)

○ Available    — Not available

# Power Monitoring Equipment

## Multiple function protectors and controllers

### F-MPC60B, F-MPC30

#### ■ Functions (continued)

Series			F-MPC60B	F-MPC30	
Type			UM43FG-E5AK	UM5ACG-H5R	
Installation location			Receiver or feeder	Feeder	
Protection	Overcurrent Instantaneous	50	○	○	
	Overcurrent Short-time	51DT1	○	○	
	Overcurrent Definite-time	51DT2	○	○	
	Overcurrent Inverse-time *1	51	○	○*2	
	Ground-fault Instantaneous	50G	○	○	
	Overcurrent Inverse-time *2	51G	○	○	
	Ground fault directional	67	—	—	
	Phase-loss	46	○*3	—	
	Inverse-phase	47	○*3	—	
	Voltage established	84	—	—	
	Undervoltage	27	○	—	
	Overvoltage	59	○	—	
	Ground-fault overvoltage	64	—	—	
	Current prealarm	OCA	○	○	
	Ground-fault current prealarm	OCGA	○	○	
	Measurement	Current (r, s, t)	A	○	○
		Voltage (line)	V	○	—
Voltage (phase)			○	—	
Active power (±)		W	○	—	
Reactive power (±)		Var	○	—	
Power-factor (±)		PF	○	—	
Frequency		Hz	○	—	
Active electric energy (+)		WHM	○	—	
Active electric energy (-)		WHM	○	—	
Reactive electric energy (+)		VarH	○	—	
Reactive electric energy (-)		VarH	○	—	
Ground fault (zero-phase) voltage		V0	—	—	
Ground fault (zero-phase) current		A0	○	○	
Harmonic current (3, 5, 7, Total)		HA	○	—	
Harmonic voltage (3, 5, 7, Total)		HV	—	—	
Demand current (r, s, t)		DA	○	—	
Demand active power		DW	○	—	
Max. zero-phase current value			○	○	
Max. zero-phase voltage value			—	—	
Max. demand current value (r, s, t)			○	—	
Max. demand power			○	—	
Total electric energy (+)			○	—	
Total electric energy (-)			○	—	
Min. voltage value (between lines)		○	—		
Preventive maintenance	50(INST)	Operation Count	○	○	
	51DT1	Operation Count	○	○	
	51DT2	Operation Count	○	○	
	51	Operation Count	○	○	
	67DG	Operation Count	—	—	
	50G	Operation Count	○	○	
	51G	Operation Count	○	○	
	OCA	Operation Count	○	○	
	OCGA	Operation Count	○	○	
	Phase loss	Operation Count	○*3	—	
	Inverse phase	Operation Count	○*3	—	
	27	Operation Count	○	—	
	59	Operation Count	○	—	

\*1 with SI, VI, LT, EI, and I<sup>2</sup>t characteristics      \*3 Available for version 1 or later.

\*2 with SI, VI, LT, and EI characteristics

○ Available    — Not available

**Multiple function protectors and controllers  
F-MPC60B series, UM43FG-E5AK**

**■ Description**

Although the F-MPC60B series is very compact, it integrates multiple functions in one body, such as protection, measurement, operation, and monitoring of high-voltage power distribution and switching facilities. It can also transmit the data obtained with these functions to upper level controllers.

**■ Features**

**Flexibility**

In accordance with changes in circuit conditions such as CT ratio, the setting of the F-MPC60B can be easily changed.

**Improved maintainability**

Preventive maintenance and fault analysis can be easily made with the functions that display operation history and fault data.

**High reliability**

To prevent operation errors such as circuit disconnection, the F-MPC60B series has dual CPUs that check with each other for confirmation and dual output circuits from which output signals are always checked.



**RS-485 communication interface**

Two protocol types are available: MPC-Net protocol and MODBUS protocol.\*

Note: \* MODBUS protocol is available for version 1 or later.

**■ Specifications**

**• General specifications**

Type	UM43FG-E5AK	
Control power supply	100V DC (80 to 143V)/ 100V AC (85 to 132V) common use	
Control power consumption	Max. 15W	
Power consumption of CT, VT	Max. 1.0VA	
Rated current (CT secondary current)	5A AC ( "1A AC" model is also available (non-standard).)	
Rated voltage	Line voltage	Select "110V AC" or " 110X√3 AC" (VT secondary voltage)
	Phase voltage	Select "110V /√3 AC" or "110V AC" (VT secondary voltage)
Zero-phase current	5A AC	
Insulation resistance	10MΩ (min.) between ground and electric circuits connected together	
Vibration resistance	16.7Hz 1.96m/s <sup>2</sup> , 0.4mm double amplitude, 10 minutes each in X, Y, and Z directions	
Shock resistance	300m/s <sup>2</sup> , three times each in X, Y, and Z directions	
Withstand voltage	2kV AC 1 minute between ground and electric circuits connected together, excluding, RS-485 signal, MN signal, and kWh-pulse output signal cables	
Noise resistance	JEC2500 (conforming to ANSI), square wave, 1.5kV, 1ns/1μs, for 10 minutes.	
Overload resistance	CT circuit: at rating 40times, a second, 2 times VT circuit: at rating 1.25 times, 10 second	
Lightning impulse noise resistance	5.0kV (between ground and electrical circuits connected together)	
Dropout tolerance	20ms (Operation continues, however, display goes out.)	
Electrostatic discharge	Contact discharge: ±8kV Aerial discharge: ±15kV	
Ambient temperature	Operating: -10 to + 60°C (operation guaranteed) 0 to + 40°C (characteristics guaranteed) (no icing) *1 Storage: - 25 to + 70°C (no icing)	
Humidity	20 to 90% RH (no condensation)	
Atmosphere	No corrosive gas and no heavy dirt and dust.	
Grounding	Class D grounding (100Ω or less)	
Applicable standard	JEC2500 (Protective relays for electric power systems), JEC-2510 (Overcurrent relays), JEC-2511 (Voltage relays), JIS C4602 (Overcurrent relays for 6.6kV receiving), JIS C1102-1 to -9 (Direct acting analogue electrical instrument and their accessories), IEC255-3 (1989), -5, -6	
Mass	1.4kg	

\*1: The operation guaranteed temperature is a temperature at which operation is guaranteed within two times of the guaranteed accuracy value at JEC characteristics guaranteed temperature, or within the accuracy of influence of JIS temperature.

# Power Monitoring Equipment

## Multiple function protectors and controllers

### F-MPC60B

#### ■ Specifications

##### • Input/output specifications

Input circuit	Applicable to both 100V DC (max. 143V) and 100V AC (max. 132V) Pick up voltage: 40 to 70V DC/40 to 70V AC	
Output circuit	Circuit breaker ON/OFF/trip	Making current: 15A (110V DC), allowable continuous current: 4A
	Other than above	Making/breaking current: 0.2A (110V DC, inductive load L/R = 15ms or less), allowable continuous current: 1A

##### • Measurement and display specifications

	Effective measuring and display range	Accuracy *2
Current/Demand current/ Max. demand current	0, 0.8% to CT rating to 8 × CT rating *1	±1.5% (0, 0.8 to 100%), ±5% (100 to 800%)
Zero-phase current/Max. zero-phase current	CT: 0, 2% to CT rating to 8 × CT rating	±1.5%: 0, 2% to CT rating, ±5%: others
Active power Demand active power/ Reactive power	±0.004 to ±1kW at VT secondary circuit (The value is converted into the VT rated voltage)	±1.5% : 0, ±0.004 to ±1kW See the figure below.
Power factor	Lead 0% - 100% - Lag 0%	±5% (Lagging: no sign, leading: - sign) See the figure below.
Active electric energy *3 Reactive electric energy	0 to 99999, multiplying factor: 1, 10, 100, 1000	Equivalent to ordinary instruments shown in Table 4 specified in JIS C 1216 (instrument with a transformer)
Line voltage	9.5 to 260V on VT secondary side	±1.5%
Phase voltage	5.5 to 150V on VT secondary side	±1.5%
Frequency	45 to 55Hz (50Hz), 55 to 65Hz (60Hz)	±0.5%
Max. demand value	Same as the above range	—
Harmonics current	3rd, 5th, 7th, overall harmonics	—

\*1 The fault current up to 2000% (accuracy: ±5%) can be displayed.

\*2 "0, a to n%" means that "0" is indicated if a value is less than a%.

\*3 There are two indications in the electric energy indication; total electric energy indication (zero clear disable) and periodic electric energy indication (zero clear is enable).

#### The sign "±" in electric measuring

The sign "±" is used to display "LEAD/LAG" in power-factor, measuring and "electric power selling/purchase" in electric power measuring. No signs are used if a value is "+". The sign "±" has the following meanings depending on the measured items.

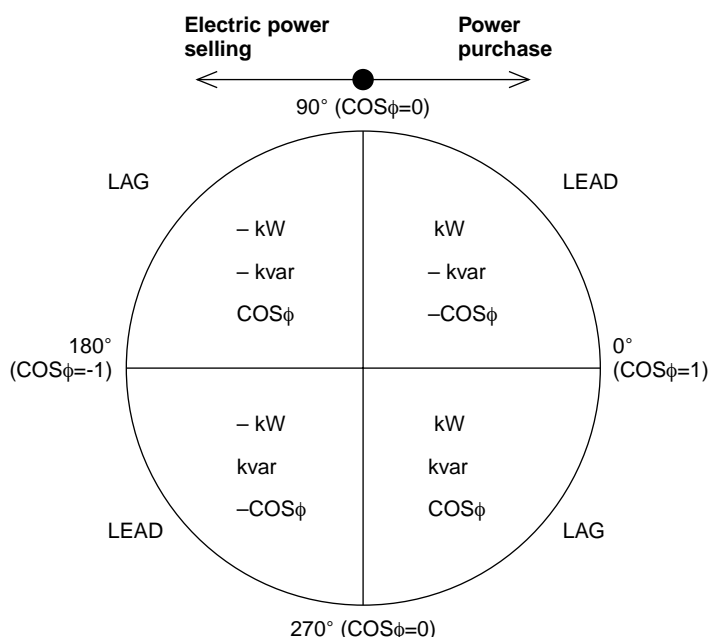

- Active power: kW  
+: Power purchase (Consumed electric power)  
-: Electric power selling (Inverse electric power flow)
- Reactive power: kvar  
+: Lagging current by reactive volt-ampere meter method  
-: Leading current by reactive volt-ampere meter method  
\* "LEAD/LAG" reverses with electric power selling/purchase.
- Power factor:  $\text{COS}\phi$   
+: LAG -: LEAD

■ Specifications

● History data

Item	Display range	Display code
50 (INST) operation count	0 to 9999	H0
51DT1 operation count	0 to 9999	H1
51 (OC) operation count	0 to 9999	H2
51G operation count	0 to 9999	H3
50G operation count	0 to 9999	H4
59 (OV) operation count	0 to 9999	H6
27 (UV) operation count	0 to 9999	H7

\* Other history display: Fault value display (on occurrence of a fault), history maximum values of zero-phase current/voltage, maximum demand value (A, W), and minimum instantaneous voltage

Item	Display range	Display code
46 operation count	0 to 9999	H9
47 operation count	0 to 9999	HA
OCA operation count	0 to 9999	Hb
Running time	0 to 9999 × 100 (h)	Hc
ON/OFF operation	0 to 9999 × 10 (times)	Hd
OCGA operation count	0 to 9999	Hn
51DT2 operation count	0 to 9999	HP

\* The display codes are the codes to be displayed on this F-MPC60B (UM43FG-E5AK).

● Specifications of protective relays

Item	Setting range of current/voltage operate value	Setting range of operate time (timer)	Characteristics	
			Operate value	Operate time
50 (Instantaneous)	1 to 20 times of CT rated current (in 0.2 times step), Lock	Fixed	±5%	40ms or less
51DT1 (Definite time)	1 to 20 times of CT rated current (in 0.2 times step), Lock	0 to 5s (in 0.05 step)	±5%	Less than 1s ±50ms More than 1s ±5%
51DT2 (Definite time)	20 to 240% of CT rated current (2% step), Lock	0 to 10s (0.1s step)	±5%	Less than 1s ±50ms More than 1s ±5%
51 (Inverse time) SI, EI, VI, LT, I <sup>2</sup> t	20 to 240% of CT rated current (2% step), Lock	Time multiplication: 0.5 to 20 times, (in 0.1 times step) (Minimum operation time: 150ms)	±5%	Setting = 300%: ±12% 500, 1000%: ±7% (lower limit ± 100ms)
50G, 50N (Instantaneous/definite time)	0.2 to 8 times of CT rated current (in 0.1 times step), Lock	0.0 to 10s to 180s *1	±5%	±5% (lower limit ±50ms)
51G, 51N SI, EI, VI, LT	0.02 to 1.00 times of CT rated current (in 0.01 times step), Lock	Time multiplication: 0.5 to 20 times (in 0.1 times step) (Minimum operation time: 150ms) *1	±5% (min. ± 100mA)	Setting = 300%: ±12% 500, 1000%: ±7% (lower limit ± 100ms)
59V (OV)	VT secondary voltage: 60 to 150V (1V step), lock	0.0 to 5.0s to 60s (in 0.5s step) (in 1s step)	±5%	±5% (min. ±50ms)
27V (UV)	VT secondary voltage: 10 to 100V (1V step), lock	0.0 to 5.0s to 60s (in 0.5s step) (in 1s step)	±5%	±5% (min. ±35ms)
46 (Open-phase)	—	—	Unbalanced rate 50 - 80%	2s (fined)
47 (Phase sequence relay)	—	—	—	0.5s on less
OCA (Overcurrent pre-alarm)	10 to 100% of CT rated current (in 5% step), Lock	10 to 200s (in 10s step)	±10%	±5%
OCGA (Leakage current pre-alarm)	50, 60, 70, 80% of the setting value of "51G operating current", Lock	10 to 200s (in 10s step)	±10% (min±200mA)	±5%

\*1 When a current exceeds 15% of the rated fundamental wave current, the malfunction preventive function against the exciting inrush current activates. (When the contents of the second higher harmonics are about 15% or higher, the feature will lock outputs.) Note that with the 50G relay, the malfunction preventive function against the exciting inrush current will not activate if you set the operate time at 0s.

● Communications specifications

Protocol	MODBUS protocol mode	MPC-Net mode
Standard	EIA-485	EIA-485
Data exchange method	polling/selecting system	1: N polling/selecting system
Transmission distance	1000m (total length)	1000m (total length)
No. of connectable units	Up to 32 units (including master unit)	Up to 32 units (including master unit)
Station number address	01 to 99	01 to 99
Transmission speed	4800/9600/19200 bps (selectable)	4800/9600/19200 bps (selectable)
Data format	Number of start bits: 1 (fixed) Data length: 8 bits (fixed) Parity bit: None/even/odd (selectable) Stop bits: 1 bit or 2 bit (automatic selection) 1 bit: for "even or odd" parity 2 bit: for "none" parity	Number of start bits: 1 (fixed) Data length: 7/8 bits (selectable) Parity bit: None/even/odd (selectable) Stop bits: 1 (fixed) BCC= Even horizontal parity

# Power Monitoring Equipment

## Multiple function protectors and controllers

### F-MPC60B

#### ■ Specifications

##### • Specifications of transducer outputs

Transducer output signal		4 to 20mA DC (external load resistance: 270Ω or less)	
Signal type	Current (Ia, Ib, Ic)	4 to 20mA for 0 to CT rated current	Accuracy ±1.5%
	Line voltage (Vab, Vbc, Vca)	For VT secondary 0 to 150V, 4 to 20mA * <sup>1</sup> 0 to 150V ×√3, 4 to 20mA * <sup>2</sup>	
	Phase voltage (Van, Vbn, Vcn)	For VT secondary 0 to 150V/√3, 4 to 20mA * <sup>1</sup> 0 to 150V, 4 to 20mA * <sup>2</sup>	
	Active power (W)	For 0 to 1kW (CT5A, VT110V AC conversion), 4 to 20mA	
	Reactive power (var)	For -1 to 0 to 1kvar (CT5A, VT110V AC conversion), 4 to 12 to 20mA	
	Frequency (Hz)	For 45 to 55Hz or 55 to 65Hz, 4 to 20mA	
	Power factor	For LEAD 0.5 to 1 to 0.5 LAG, 4 to 12 to 20mA	

Note: • Output signals are connected to a common terminal (minus side).

• An upper or lower limiter operates when the output signal is about to exceed the upper or lower limit.

The upper limit is fixed at 20mA, and the lower limit is fixed at 20mA.

\*<sup>1</sup>: Applied line voltage: 100V/110V/120V AC.

\*<sup>2</sup>: Applied line voltage: 100V/110V/120V AC ×√3, AC.

##### • Specifications of kWh pulse output

Type of output	Transistor, open collector
Ratings	Max. 150V DC, 100mA
Pulse width	200 ± 20ms
Pulse rate	10 <sup>n</sup> kWh per pulse (n=-2 to 4) (integer), or 2000 pulses per kWh

#### ■ Type number nomenclature

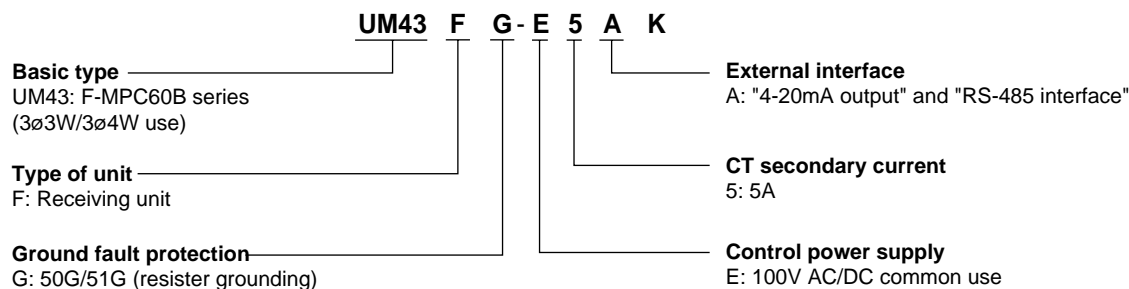

■ Example of external wiring diagrams

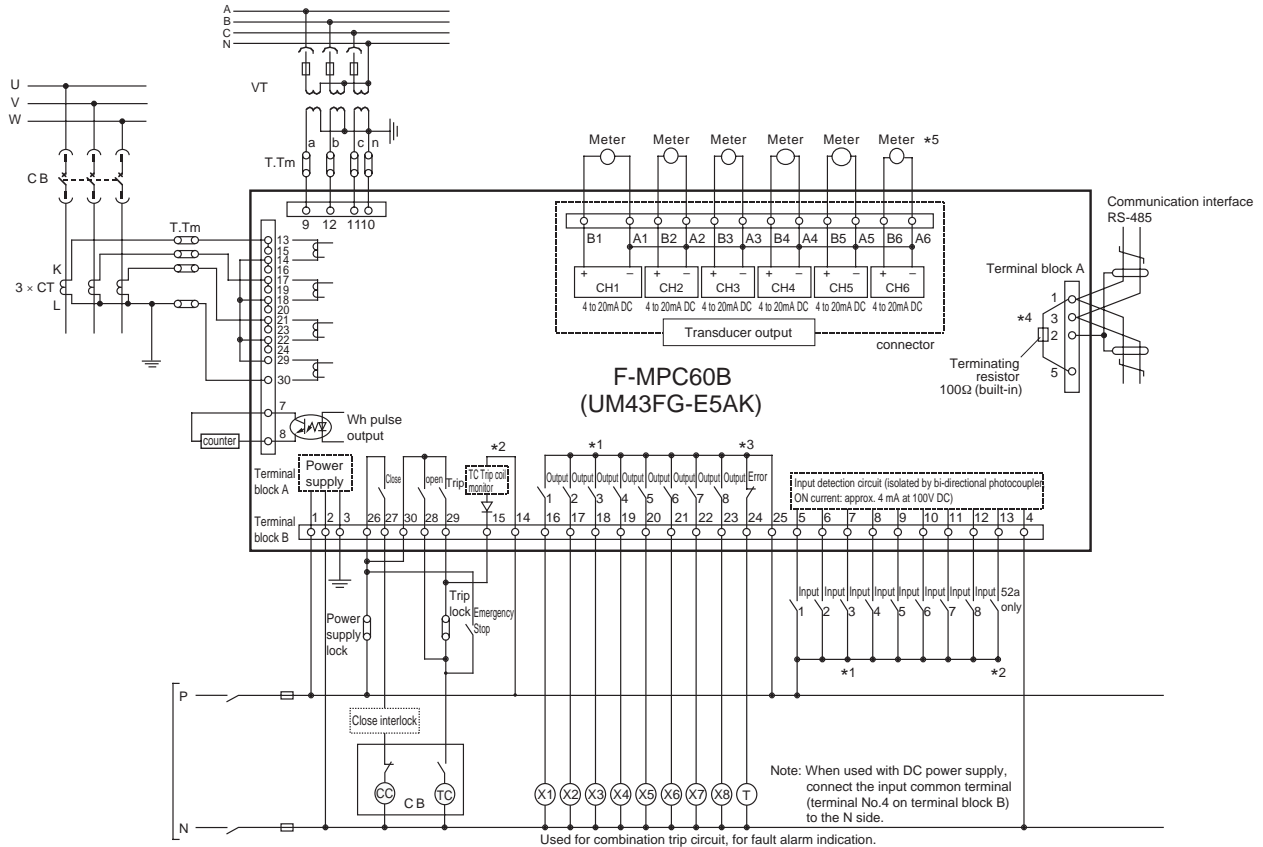

- Note:
- \*1 Use selective input 1 to 8 and selective output 1 to 8 by selecting the function type by setup.
  - \*2 Outputs of "ON, OFF, TRIP and equipment error" are used exclusively. Inputs of "52a: the answer back signal of CB ON" and "the monitoring of TC coil" are used exclusively.
  - \*3 Equipment error output is a normally closed contact (normally excited, and if an error occurs, excitation terminates and contact opens). Therefore, a time delay of about 100ms occurs before the contact opens, since the power has been on (in operation). Consider the use of a timer, if necessary, if you create an external sequence.
  - \*4 If this unit, being provided with RS-485 communication function, is located at the termination of a communication line, connect terminals No.3 and 5. With this, the 100Ω terminating resistor is connected across the RS-485 bus.
  - \*5 Use twisted wires (cables) as the output cable of transducer.
  - If you have to connect a heavy load exceeding relay's contact rating, be sure to use it in combination with FUJI's miniature power relay HH6□. See page 09/106 "Input/output specifications."

# Power Monitoring Equipment

## Multiple function protectors and controllers

### F-MPC60B

#### ■ Time-current characteristic

##### Standard inverse (SI) characteristics

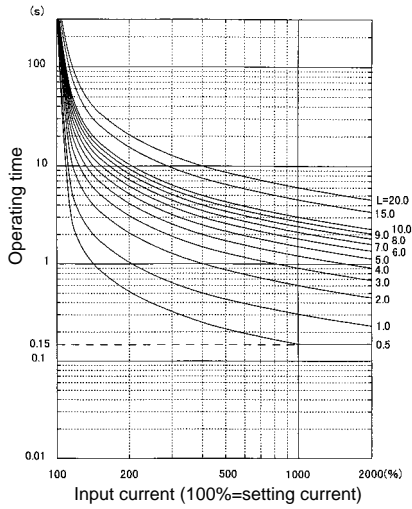

Note:  
Time setting (lever) is of 0.1 times step (Lower limit: 0.5, upper limit: 20.0). Indication of a part of the lever is omitted in the characteristics indicated above.

$$t = \frac{0.14}{I^{0.02} - 1} \times \frac{L}{10} \quad (L: \text{time magnification})$$

##### Very inverse (VI) characteristics

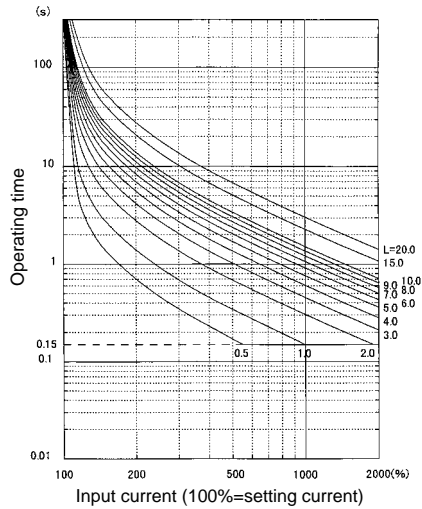

Note:  
Time setting (lever) is of 0.1 times step (Lower limit: 0.5, upper limit: 20.0). Indication of a part of the lever is omitted in the characteristics indicated above.

$$t = \frac{13.5}{I - 1} \times \frac{L}{10} \quad (L: \text{time magnification})$$

##### Very inverse (LT) characteristics

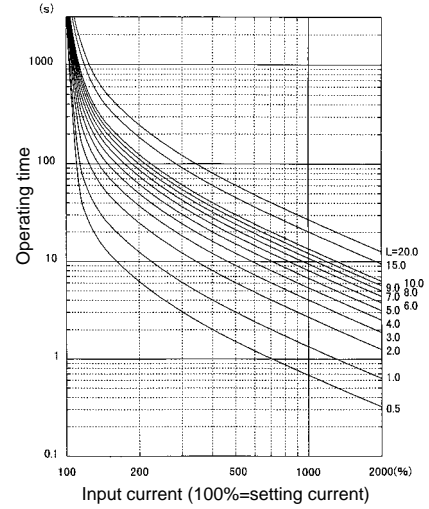

Note:  
Time setting (lever) is of 0.1 times step (Lower limit: 0.5, upper limit: 20.0). Indication of a part of the lever is omitted in the characteristics indicated above.

$$t = \frac{120}{I - 1} \times \frac{L}{10} \quad (L: \text{time magnification})$$

##### Extremely inverse (EI) characteristics

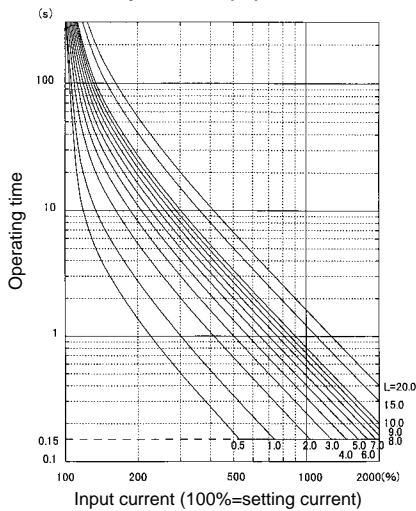

Note:  
Time setting (lever) is of 0.1 times step (Lower limit: 0.5, upper limit: 20.0). Indication of a part of the lever is omitted in the characteristics indicated above.

$$t = \frac{80}{I - 1} \times \frac{L}{10} \quad (L: \text{time magnification})$$

##### I<sup>2</sup>t characteristics

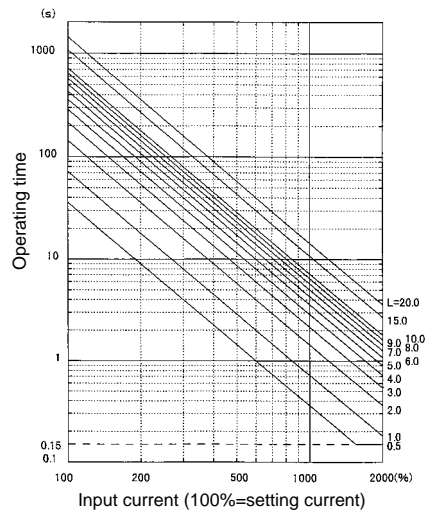

Note:  
Time setting (lever) is of 0.1 times step (Lower limit: 0.5, upper limit: 20.0). Indication of a part of the lever is omitted in the characteristics indicated above.

$$t = \frac{720}{I} \times \frac{L}{10} \quad (L: \text{time magnification})$$

■ Dimensions, mm

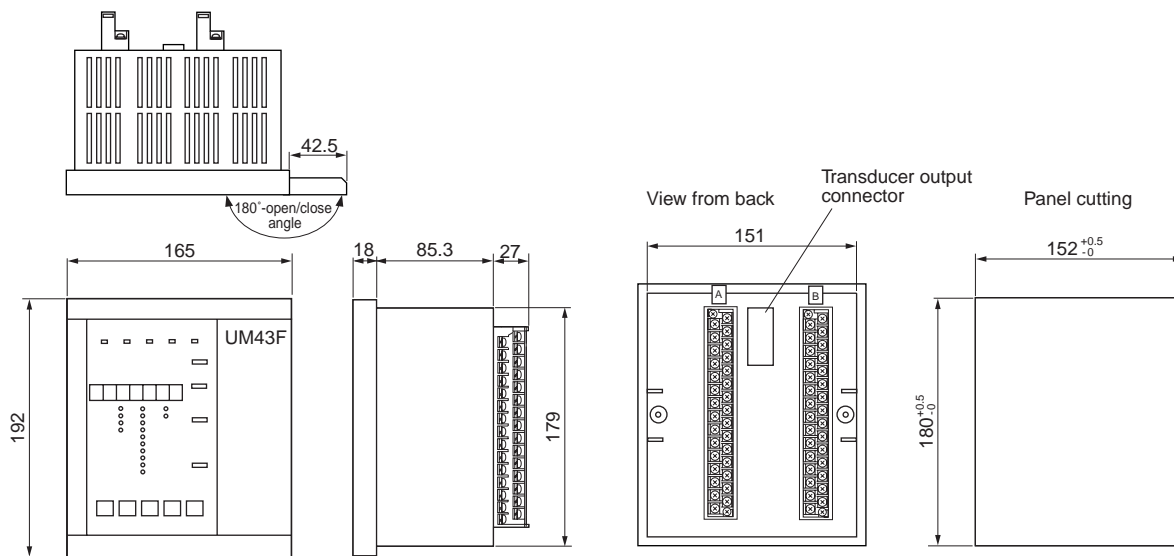

Minimum clearance from adjacent upper and lower devices or panel plate: 100mm

■ Characteristics of overcurrent relay (OCR)

The characteristics of overcurrent relays (OCR) are, in general, divided into the protective INST (50) (setting code 10, 11), the protective DT1 (setting code 12 to 14), protective DT2 (setting code 1c, 1d, 1E) and the protective OC 51 (setting code 15 to 18). The characteristics of protective OC 51 consist of 5 kinds

of inverse characteristic curves, such as standard inverse (SI) characteristics, very inverse (VI) characteristics, long time inverse (LT) characteristics, extremely inverse (EI) characteristics and I<sup>2</sup>t characteristics). Combination of the protective INST (50), protective DT1, protective DT2 and OC 51 carries out coordinative protection.

Outline of characteristic of overcurrent relay

Item	Operating current	Operating time
Protective INST (50)	1 to 20 times of CT rated current 5A (0.2 times step)	Fixed (40ms or less)
Protective DT1		0 to 5s (0.05s step)
Protective DT2	20 to 240% of CT rated current 5A (2% step) *1	0 to 10s (0.1s step)
Protective OC (51)		Select from 5 characteristic curves. Time magnification: 0.5 to 20 times (0.1 times step)

\*1: The operating time of protective OC51 is saturated at about 150ms.

The operating time will be saturated at 20 times of CT rated current when the setting exceeds 200%.

For example, the operating time becomes 833% (= 2000%/(240%×100)) of the CT rated current in 240% setting.

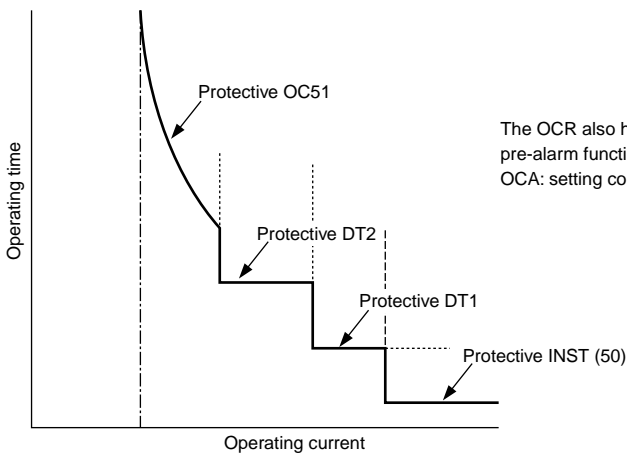

The OCR also has the pre-alarm function (protective OCA: setting code 19-1b).

# Power Monitoring Equipment

## Multiple function protectors and controllers

### F-MPC30

#### Multiple function protectors and controllers F-MPC30 series, UM5ACG-H5R

##### ■ Description

The F-MPC30 series is a multiple function protectors and controllers in the power monitoring equipment, which integrates protective, measurement, and transfer functions for power feeder facilities. Versatile functions such as preventive maintenance and history data and abnormal value recording can be achieved with excellent economy and reliability. These works have been very complicated as you must have used individual power monitoring devices in combination.

##### ■ Features

###### Economical system configuration

Includes measurement and protective functions limited to the current ranges most frequently used, thus allowing the construction of economical systems.

###### Improved operating reliability

Includes an automatic monitor function, an automatic diagnostic function supported by continuous monitoring and automatic inspection, and a fail-safe function, thus ensuring high operating reliability while minimizing daily and regular inspection tasks.



###### Easily designed coordination protection

Provided with 51DT1 and 51DT2 definite time trip characteristics that simplify the designing of coordination protection between overcurrent relays.

###### RS-485 communications interface

Two protocol types are available:  
MPC-Net protocol and MODBUS protocol.

##### ■ Specifications

###### • General specifications

Type	UM5ACG-H5R
Control power supply	100/200V DC (80 to 286V DC) 100V AC (85 to 132V) common use
Control power consumption	Max. 15W (100/200V DC), Max 25 VA (100V AC)
Power consumption of CT, VT	Max. 1.0VA
Rated current (CT secondary current)	5A AC ("1A model" is also available (non-standard))
Zero-phase current	5A AC
Insulation resistance	10MΩ min. between ground and electric circuits connected together
Vibration resistance	16.7Hz, 0.4mm double amplitude, 1.96m/s <sup>2</sup> , 10 minutes each in X, Y, and Z directions
Shock resistance	300m/s <sup>2</sup> , three times each in X, Y, and Z directions
Withstand voltage	2kV AC 1 minute between ground and electric circuits connected together, excluding RS-485 signal lines
Noise resistance	JEC 2500 (conforming to ANSI), square wave, 1.5kV, 1ns/1μs, for 10 minutes
Overload resistance	CT circuit: at rating 40 times, a second, 2 times
Lightning impulse noise resistance	4.5kV (between ground and electrical circuits connected together)
Dropout tolerance	20ms (Operation continues, however, display goes out.)
Electrostatic discharge	Contact discharge: ±8kV, Aerial discharge: ±15kV
Ambient temperature	-10 to +60°C (operation guaranteed), 0 to +40°C (characteristic guaranteed) (no icing) *1
Storage temperature	-25 to +70°C (no icing)
Humidity	20 to 90%RH (no condensation)
Atmosphere	No corrosive gas and no heavy dirt and dust.
Grounding	Class D grounding (100Ω or less)
Applicable standard	JEC2500 (Protective relays for electric power systems), JEC-2510 (Overcurrent relays), JIS C4602 (Overcurrent relays for 6.6kV receiving), JIS C1102-1 to -9 (Direct acting analogue electrical instrument and their accessories), IEC255-3 (1989) -5, -6.
Mass	1.4kg

\*1: The operation guaranteed temperature is a temperature at which operation is guaranteed within two times of the guaranteed accuracy value at JEC characteristics guaranteed temperature, or within the accuracy of influence of JIS temperature.

• **Input/output specifications**

Input circuit		100/200V DC (286V DC or less) common use Pick-up voltage: 40 to 70V DC (Input current; 1.2mA at 100V DC, 2.4mA at 200V DC)
Output circuit	Circuit trip	The closing current: 15A (110V DC), 10A (220V DC), the allowable continuous conduction current: 4A
	Other than above	The switching current: 0.2A (110V DC, inductive load L/R = 15ms or less) The allowable continuous conduction current: 1A
		The making current: 0.1A (220V DC, inductive load L/R = 15ms or less) The allowable continuous conduction current: 1A

• **Measurement and display specifications**

	Effective measuring and display range	Accuracy *2
Current	0, 0.8% to CT rating to 8 × CT rating *1	±1.5% (0, 0.8 to 100%), ±5% (100 to 800%)
Zero-phase current	CT: 0, 2% to CT rating to 8 × CT rating	±1.5% (0, 2% to CT rating), ±5% (more than CT rating)

\*1 The fault current up to 2000% (accuracy: ±5%) can be displayed.

\*2 "0, a to n%" means that "0" is indicated if a value is less than a%.

• **History data and display ranges**

Item	Display range	Display code
50 (INST) operation count	0 to 9999	H0
51DT1 operation count	0 to 9999	H1
51 (OC) operation count	0 to 9999	H2
51G operation count	0 to 9999	H3
50G operation count	0 to 9999	H4

\* Other history display: Fault value display (on occurrence of a fault), history maximum values of zero-phase current/voltage, maximum demand value (A, W), and minimum instantaneous voltage

Item	Display range	Display code
OCA operation count	0 to 9999	Hb
Running time	0 to 9999 × 100 (h)	Hc
Close operation count	0 to 9999 × 10 (times)	Hd
OCGA operation count	0 to 9999	Hn
51DT2 operation count	0 to 9999	HP

\* The display codes are the codes to be displayed on this F-MPC30 (UM5ACG-H5R).

• **Specifications of protective relays**

	Setting range of current/voltage operatel value	Setting range of operate time (timer)	Characteristics (accuracy)	
			Operate value	Operate time
50 (Instantaneous)	1 to 20 times of CT rated current (in 0.2 times step), Lock	Fixed	±5%	40ms or less
51DT1 (Definite-time)	1 to 20 times of CT rated current (in 0.2 times step), Lock	0 to 5s (in 0.05s step)	±5%	Less than 1s ±50ms More than 1s ±5%
51DT2 (Definite-time)	20 to 240% of CT rated current (in 2% step), Lock	0 to 10s (in 0.1s step)	±5%	Less than 1s ±50ms More than 1s ±5%
51 (Inverse time) SI, EI, VI, LT	20 to 240% of CT rated current (in 2% step), Lock	Time multiplication: 0.5 to 20 times (in 0.1 times step) (Min. operation time: 150ms)	±5%	Setting value 300%: ±12% 500, 1000%: ±7% (lower limit ±100ms)
50G, 50N (Instant/definite time)	0.1 to 8 times of CT rated current (in 0.1 times step), Lock	0.0 to 10s to 180s (in 0.1s step) (in 1s step) *1 *2	±5%	±5% (lower limit ±50ms)
51G, 51N SI, EI, VI, LT	0.02 to 1.00 times of CT rated current (in 0.01 times step), Lock	Time multiplication: 0.5 to 20 times (in 0.1 times step) (Min. operation time: 150ms)*1	±5% (min. ±100mA)	Setting value 300%: ±12% 500, 1000%: ±7% (lower limit ±100ms)
OCA (Overcurrent pre-alarm)	10 to 100% of CT rated current (in 5% step), Lock	10 to 200s (in 10s step)	±10% (min. ±100mA)	±5%
OCGA (Leakage current pre-alarm)	50, 60, 70, 80% of the setting value of "51G operating current", Lock	10 to 200s (in 10s step)	±10% (min. ±200mA)	±5%

Notes: \*1 When a current exceeds 15% of the rated fundamental wave current, the malfunction preventive function against the exciting inrush current activates. (When the contents of the second higher harmonics are about 15% or higher, the feature will lock outputs.) Note that with the 50G relay, the malfunction preventive function against the exciting inrush current will not activate if you set the operate time at 0s.

# Power Monitoring Equipment

## Multiple function protectors and controllers

### F-MPC30

#### • Communications specifications

Protocol	MODBUS protocol mode	MPC-Net mode
Standard	EIA-485	EIA-485
Data exchange method	Polling/selecting system	1: N polling/selecting system
Transmission distance	1000m (total length)	1000m (total length)
No. of connectable units	Up to 32 units (including master unit)	Up to 32 units (including master unit)
Station number address	01 to 99	01 to 99
Transmission speed	4800/9600/19200 bps (selectable)	4800/9600/19200 bps (selectable)
Data format	Number of start bits: 1 (fixed) Data length: 8 bits (fixed) Parity bit: None/even/odd (selectable) Stop bits: 1 bit or 2 bit (automatic selection) 1 bit: for "even or odd" parity 2 bit: for "none" parity	Number of start bits: 1 (fixed) Data length: 7/8 bits (selectable) Parity bit: None/even/odd (selectable) Stop bits: 1 (fixed) BCC: Even horizontal parity

#### ■ Type number nomenclature

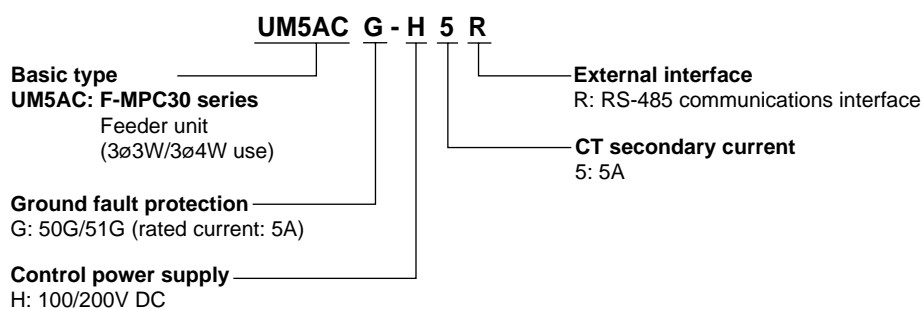

■ Example of external wiring diagram (External 3 CTs)

3-phase, 4-wire system / zero-phase current

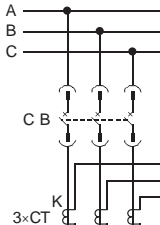

3-phase, 4-wire system / currents of phase A, B, and C synthesized with N-phase current

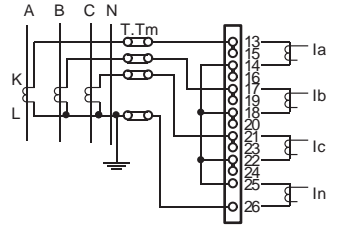

3-phase, 4-wire system / N-phase dedicated CT connection

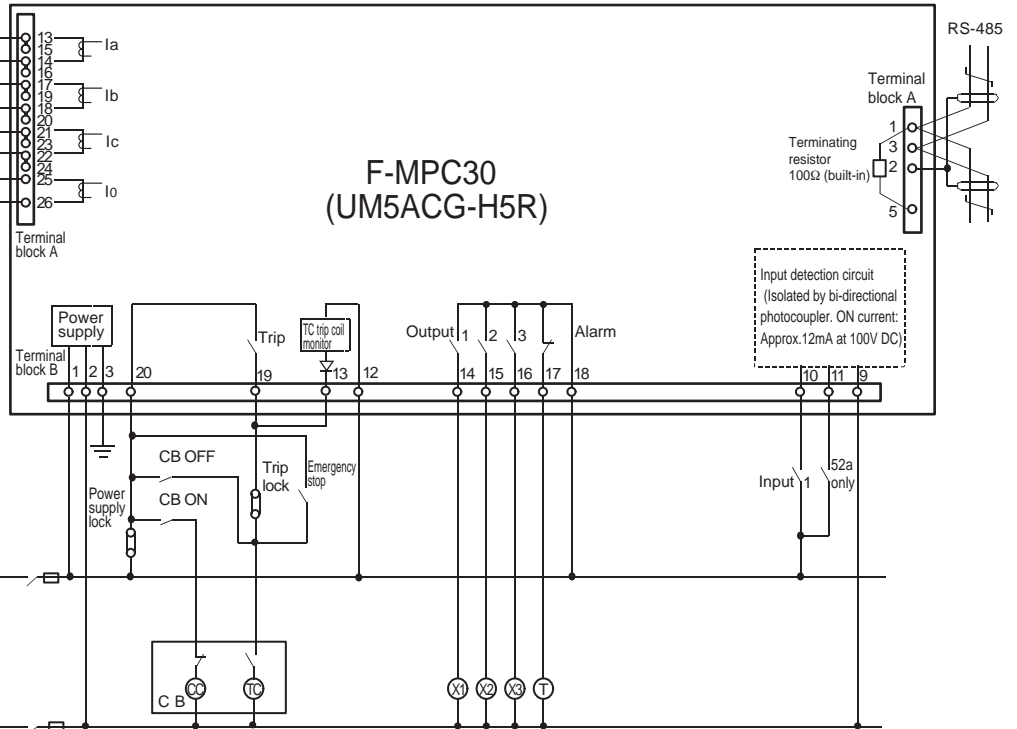
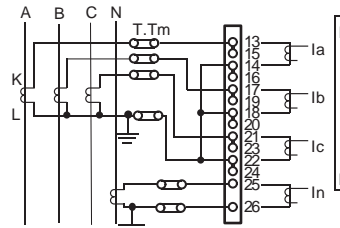

The output of X1, X2, and X3 are used for alarm display or trip display.

Note: When used with DC power supply, connect the input common terminals (terminal No.9 on terminal block B) to the N side.

- Note:
- Use selective input 1 and selective output 1 to 3 by selecting the function type by setup. See page 09/113 for details.
  - Outputs of "TRIP and device error" are used exclusively. Inputs of "52a: the answer back signal of CB ON" and "the monitoring of TC coil" are used exclusively.
  - Device error output is a normally closed contact (normally excited, and if an error occurs, excitation terminates and contact opens). Therefore, a time delay of about 100ms occurs before the contact opens, since the power has been on (in operation). Consider the use of a timer, if necessary, if you create an external sequence.
  - If you have to connect a heavy load exceeding relay's contact rating, be sure to use it in combination with FUJI's miniature power relay HH6□. See page 09/113 "Input/output specifications."
  - If this unit, being provided with RS-485 communication function, is located at the termination of a communication line, connect terminals No.3 and 5. With this, the 100Ω terminating resistor is connected across the RS-485 bus.

# Power Monitoring Equipment

## Multiple function protectors and controllers

### F-MPC30

#### ■ Time-current characteristics of an overcurrent relay

##### Standard inverse (SI) characteristics

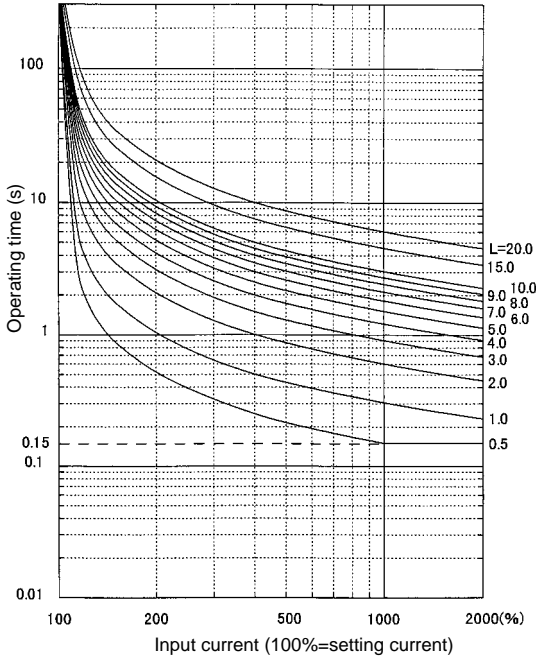

Note:  
Time setting (lever) is of 0.1 times step (Lower limit: 0.5, upper limit: 20.0). Indication of a part of the lever is omitted in the characteristics indicated above.

$$t = \frac{0.14}{I^{0.02} - 1} \times \frac{L}{10} \quad (L: \text{Time magnification})$$

##### Very inverse (VI) characteristics

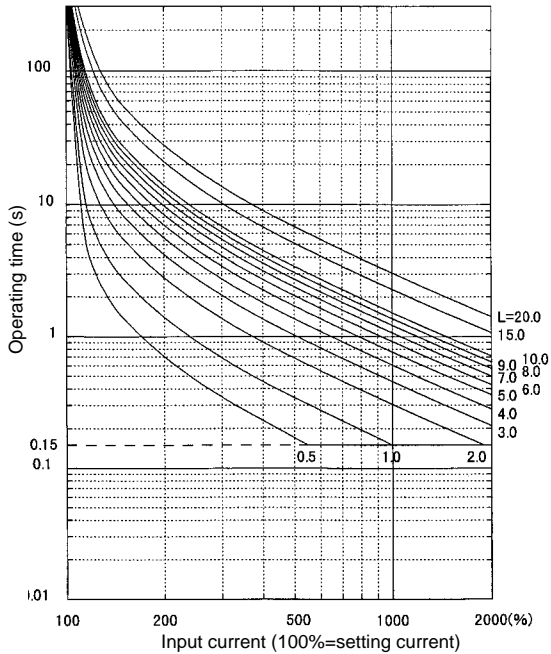

Note:  
Time setting (lever) is of 0.1 times step (Lower limit: 0.5, upper limit: 20.0). Indication of a part of the lever is omitted in the characteristics indicated above.

$$t = \frac{13.5}{I - 1} \times \frac{L}{10} \quad (L: \text{Time magnification})$$

##### Long time inverse (LT) characteristics

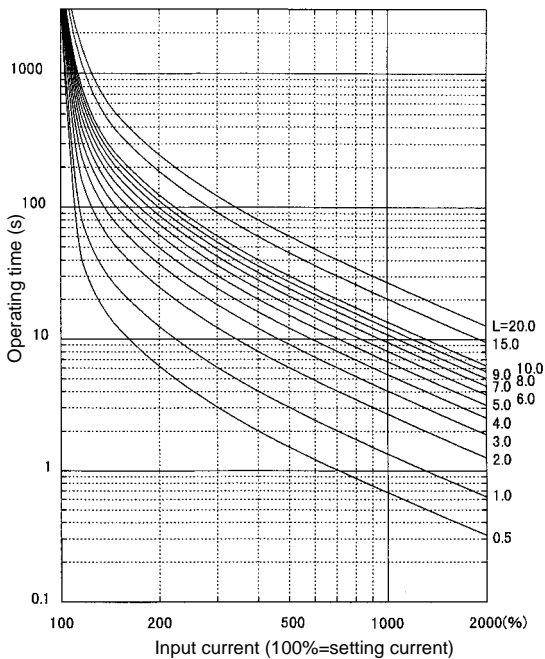

Note:  
Time setting (lever) is of 0.1 times step (Lower limit: 0.5, upper limit: 20.0). Indication of a part of the lever is omitted in the characteristics indicated above.

$$t = \frac{120}{I - 1} \times \frac{L}{10} \quad (L: \text{Time magnification})$$

##### Extremely inverse (EI) characteristics

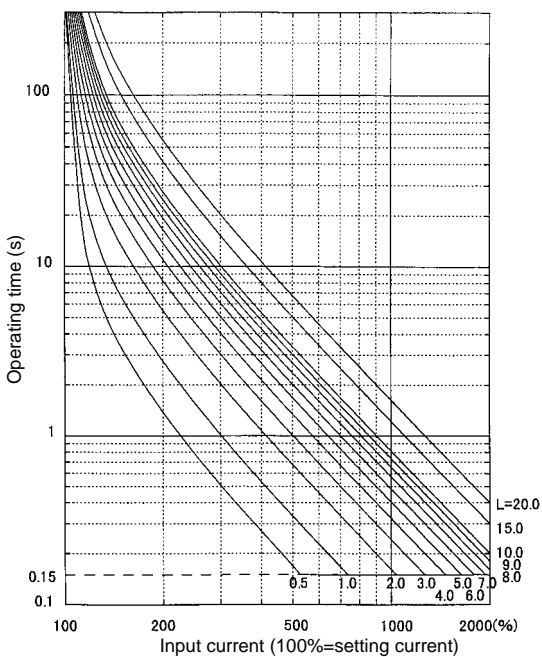

Note:  
Time setting (lever) is of 0.1 times step (Lower limit: 0.5, upper limit: 20.0). Indication of a part of the lever is omitted in the characteristics indicated above.

$$t = \frac{80}{I^2 - 1} \times \frac{L}{10} \quad (L: \text{Time magnification})$$

■ Dimensions, mm

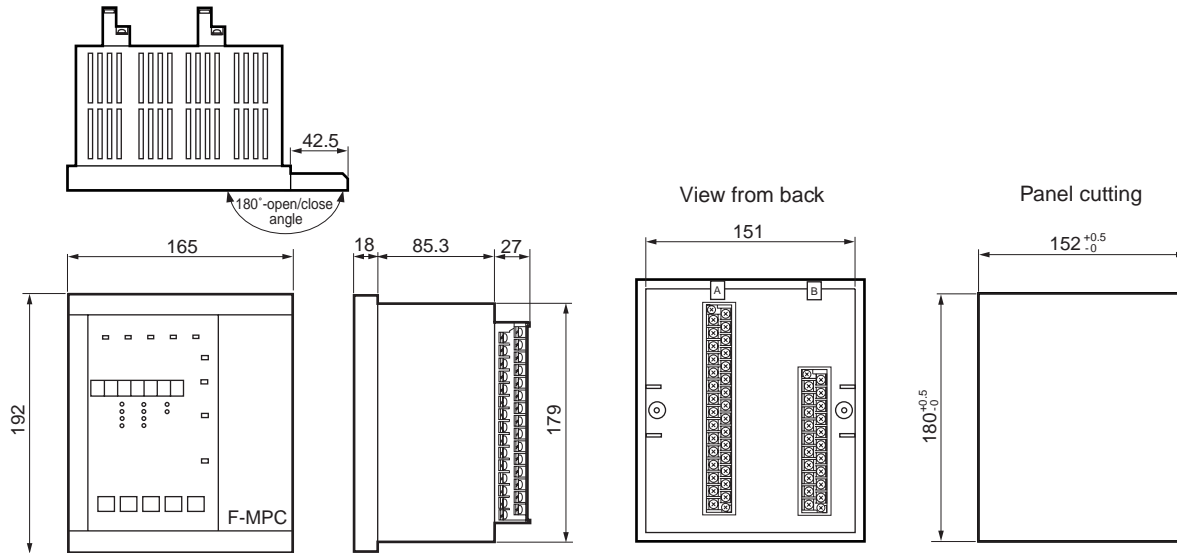

Minimum clearance from adjacent upper and lower devices or panel plate: 100mm

■ Characteristics of overcurrent relay (OCR)

The characteristics of overcurrent relays (OCR) are, in general, divided into the protective INST (50) (setting code 10, 11), the protective DT1 (setting code 12 to 14), protective DT2 (setting code 1c, 1d, 1E) and the protective OC 51 (setting code 15 to 18). The characteristics of protective OC 51 consist of 4 kinds of inverse characteristic curves, such as standard inverse (SI)

characteristics, very inverse (VI) characteristics, long time inverse (LT) characteristics, extremely inverse (EI) characteristics. Combination of the protective INST (50), protective DT1, protective DT2 and OC 51 carries out coordinative protection.

Outline of characteristic of overcurrent relay.

Item	Operating current	Operating time
Protective INST (50)	1 to 20 times of CT rated current 5A (0.2 times step)	Fixed (40ms or less)
Protective DT1		0 to 5s (0.05s step)
Protective DT2	20 to 240% of CT rated current 5A (2% step) *1	0 to 10s (0.1s step)
Protective OC (51)		Select from 4 characteristic curves. Time magnification: 0.5 to 20 times (0.1 times step)

\*1: The operating time of protective OC 51 is saturated at about 150ms.

The operating time will be saturated at 20 times of CT rated current when the setting exceeds 200%.

For example, the operating time becomes 833% (= 2000%/(240%×100)) of the CT rated current in 240% setting.

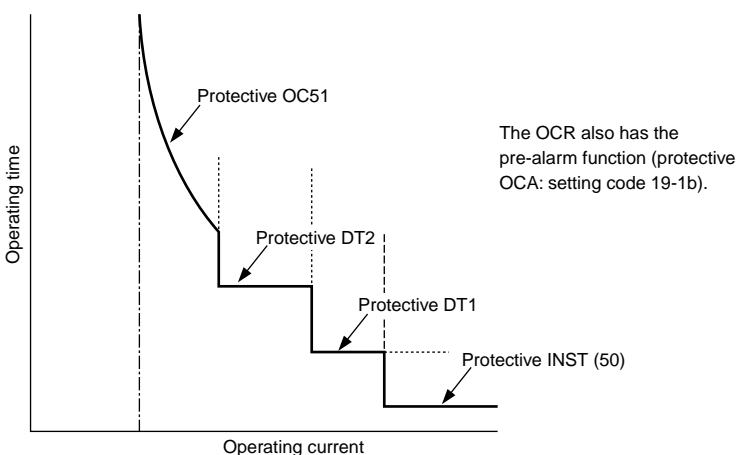

# Power Monitoring Equipment

## Power monitoring unit

### F-MPC04, F-MPC04P, F-MPC04S

#### Power monitoring unit F-MPC04 series

##### ■ Description

- F-MPC04 series power monitoring equipment, designed for used in low voltage circuits, can perform electric power management and monitoring from high to low voltage circuit efficiently and economically, used together with F-MPC60B and F-MPC30 series.
- F-MPC04 series consists of 3 types: type UM04 integrated power monitoring unit that can monitors up to 10 feeders, type UM02 multi-circuit power monitoring unit that is space-saving and can monitor up to 8 feeders in three-phase three-wire system, and type UM03 single circuit power monitoring unit, being compact, that has optimum output functions for preventive maintenance, and is best suited for installation in a unit of facility, section, and floor.
- RS-485 communications interface is standard. With our application software of F-MPC-Net power monitoring system, you can automatically display, print, and save the data measured by F-MPC 04 on your PC.

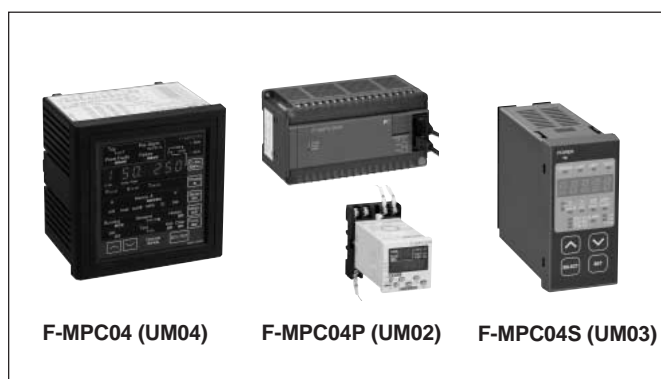

Type			F-MPC04	F-MPC04P			F-MPC04S		
			UM04-ARAE	UM02-AR2	UM02-AR3	UM02-AR4	UM03-ARA3G	UM03-ARA3	
			Integrated power monitoring unit	Multi-circuit power monitoring unit			Single-circuit power monitoring unit		
Measuring function	No. of phase and wire	1-phase 2-wire	10 circuits	12 circuits	—	—	1 circuit	1 circuit	
		1-phase 3-wire	10 circuits	—	8 circuits	—			
3-phase 3-wire									
3-phase 4-wire		6 circuits	—	—	4 circuits	—	—		
No. of voltage circuit			2	1			1	1	
Measuring item	Voltage [V] Current [A] Power [W] Active power [Wh] Reactive power [var] Reactive energy [varh] Power-factor		○			○	○	○	
			○		○		○	○	
			○		○		○	○	
			○		○		○	○	
			○		○		○	○	
			○		○		○	○	
			○		○		○	○	
			○		○		○	○	
Maintenance item	Demand	Current	○		—		○	○	
		Power	○		—		○	○	
		Max. current	○		—		○	○	
		Max. power	○		○		○	○	
	Max. voltage value	○		○		—	—		
	Min. voltage value	○		○		—	—		
Harmonic current			○		—		○ (Demand only)		
Protection	Current prealarm (OCA)		○		—		○	○	
	Leakage current prealarm (OCGA)		○		—		○	—	
	Leakage current trip (OCG)		○		—		○	—	
Communications interface			RS-485, Modbus	RS-485			RS-485	RS-485	
Display and setting			○	Display and setting unit UM02X-S			○	○	
Devices to be connected	Current sensor (Current Transformer:CT)		○ *1	CT: 5, 50, 200, 400A					
	ZCT (separately installed)		○		—		○	—	
	MCCB with ZCT		○		—		○	—	

Note \*1: FMPC 04 (UM04) is connected to CT via CT-BOX. For combination of F-MPC04 (UM04), CT-BOX and CT, See page 09/120 and 09/135 ; "Applicable CT."

■ System configuration example  
**Low voltage**

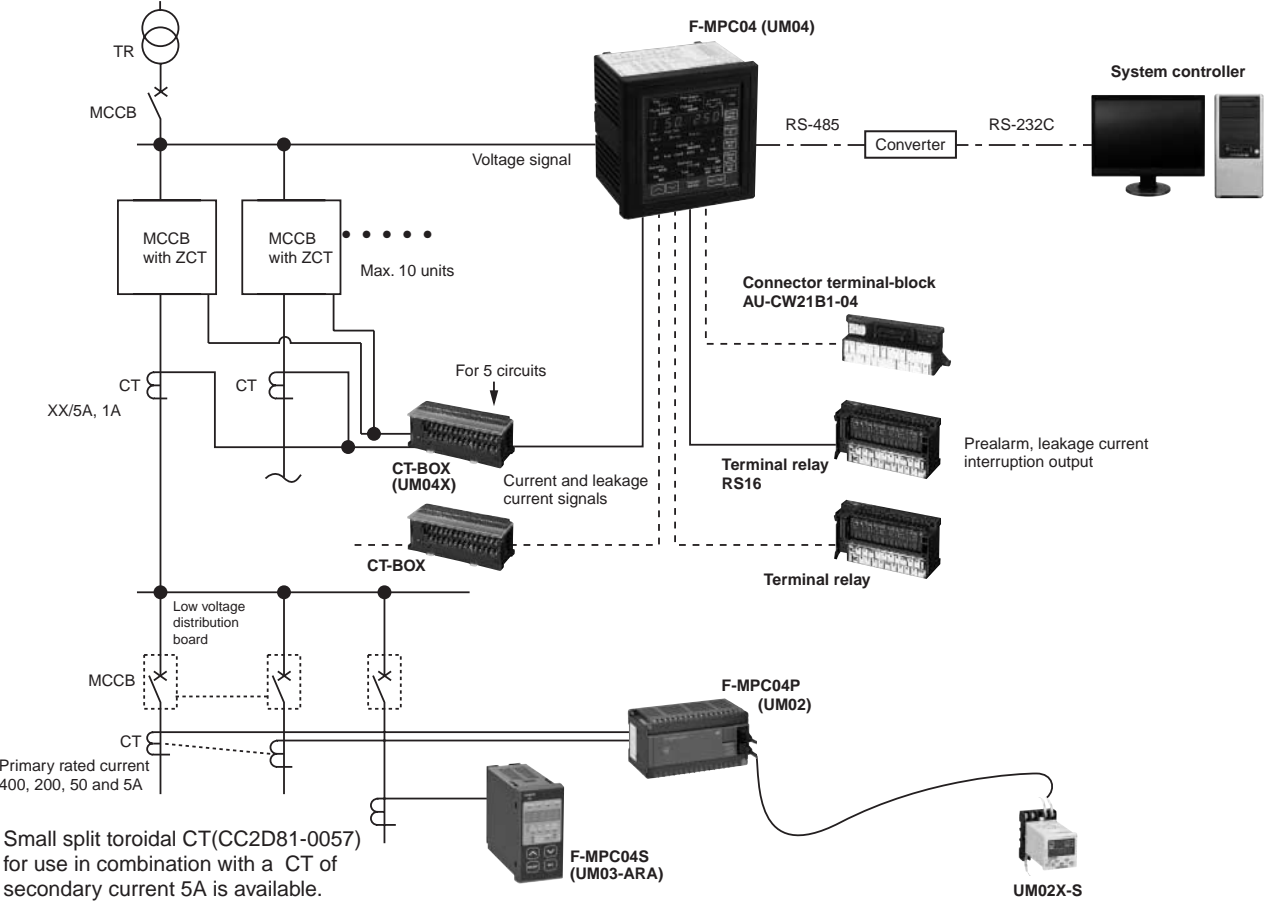

# Power Monitoring Equipment

## Power monitoring unit

### F-MPC04

#### Integrated power monitoring unit, UM04

##### ■ Description

Integrating complete functions required for power distribution and power line data management in a single unit (up to 10 circuits for 3-phase 3-wire system)

- Supports multiple power distribution lines  
UM04 allows economical management of each facility and installation by means of communications interface.
- Easy mounting to existing switchboards  
Split-through type CTs enables UM04's easy mounting to existing boards.
- Flexible energy management  
UM04 manages power line data such as measurement, preventive maintenance, maintenance and electricity quality, and transmit those data to upper level controller, thus promises energy and labor-saving.
- Harmonics current measurement  
The third, fifth, seventh, and total harmonic current can be measured.
- Monitor insulation deterioration and implement preventive maintenance by measuring leakage current.  
Provides deterioration trend analysis with trend data and preventive maintenance with 2-stage output (leakage current pre-alarm and leakage current relays).
- Compatible with MODBUS RTU protocol.  
Select between the MODBUSRTU protocol or the F-MPC-Net protocol for the F-MPC series.

##### ■ Type number nomenclature

Integrated power monitoring unit



##### ■ Types

Description	Specification	Type	Remarks
Integrated power monitoring unit	RS-485, 2VT-conformed	<b>UM04-ARA4</b>	
CT-BOX	For CT secondary current 5A	<b>UM04X-5</b>	
	For CT secondary current 1A	<b>UM04X-1</b>	
Related product			
Terminal Relay	15 output	<b>RS16-DE04H</b>	See page 09/137.
Connector cable	Length 1m/2m/3m	<b>AUX014-20□</b>	See page 09/137.
Connector terminal block	kWh pulse output For digital input	<b>AU-CW21B1-04</b>	See page 09/138.

##### ■ Applicable CT

Current transformer (CT)	CT secondary current	Applicable CT-BOX	Applicable integrated power monitoring unit
Split CT Type CC2C76-□□□1 Type CC2D74-□□□1	1A	UM04X-1	UM04-ARA4
General-purpose CT XX/1A	1A		
General-purpose CT XX/5A	5A	UM04X-5	

Applicable circuit	CT-BOX	
	One unit	Two units
Three-phase/3-wire	5 feeders max.	10 feeders max.
Single-phase/2-wire		
Single-phase/3-wire		
Three-phase/4-wire	3 feeders max.	6 feeders max.

\* The number of countable feeders depends on the number of CT boxes.

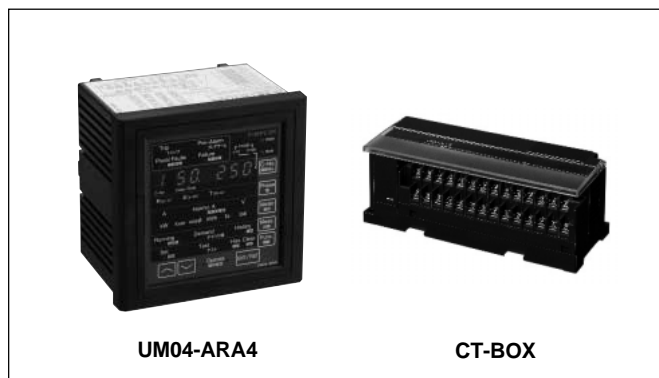

- Handles digital input.  
Four inputs (ON/OFF status and pulse count digital signals) from the relay connector terminal block.
- Related Equipment  
Molded case circuit breakers with ZCT and split type current transformers are also introduced as related products, RS16 Terminal Relay which outputs leakage current prealarm and the connector terminal-block which outputs kWh pulse, are also explained (UM04 use only).

■ **Specifications**

• **General specifications**

Item	Specification	
Rating	Rated frequency	50 or 60Hz (Selectable by the setting)
	Rated voltage	Applicable to both 110V and 220V AC, 110V AC for use with a VT secondary circuit
	Rated current	Depends on CT-BOX specifications (5A, 1A in a CT secondary circuit, power consumption: 0.1VA max., excluding power loss in the external cable resistance)
	Zero-phase CT	EW type or MCCB with a ZCT (zero-phase current transformer ) type (FUJI model)
Control power supply	85 to 264V AC (By exclusive control power supply terminal)	
Inrush current	40A max., 3ms max. (AC) 85A max., 3ms max. (DC)	
Control power consumption *1	25VA max. (Power monitoring unit + two CT-BOXes + Terminal Relays with all contacts ON)	
Rated input	Voltage input (VT ratio)	100V direct input, 200V direct input VT primary/secondary : AC220/110V, AC440/110V, AC440/220V, AC240/110V, AC400/110V, AC3.3k/110V, AC6.6k/110V
	Current input (CT ratio)	Primary rating setting : 10A, 15A, 20A, 25A, 30A, 40A, 50A, 60A, 75A, 80A, 100A, 120A, 150A, 160A, 200A, 250A, 300A, 320A, 400A, 500A, 600A, 630A, 750A, 800A, 100A, 1200A, 1250A, 1500A, 1600A, 2000A, 2500A, 3000A, 3150A, 3200A, 4000A, 5000A, 6000A, 7500A
Ambient temperature	-10 to + 55°C (no icing or no condensation)	
Storage temperature	-20 to + 70°C (no icing or no condensation)	
Humidity	20 to 90% RH (no condensation)	
Atmosphere	No corrosive gas and no heavy dirt and dust	
Alarm and shutdown outputs	Continuous output current: 1A max. (with output of terminal relay, RS16-DE04H) Make and break current: 250V AC 5A, 30V DC 5A max.	
Insulation resistance	10MΩ min.: between ground and electric circuits connected together 5MΩ min.: between electric circuits, between contacts	
Dielectric strength	2000V AC, 1 minute between ground and electric circuits connected together, excluding T-link and RS-485 signal circuits	
Impulse	4.5kV (1.2 × 50μs) between ground and electric circuits connected together, excluding T-link and RS-485 signal circuits	
Momentary overload capability	20 times rated current, nine times for 0.5s, once for 2s	
Shock resistance	Approx. 300m/s <sup>2</sup> , three times in each of X, Y, and Z axes	
Noise immunity	1 to 1.5MHz damped oscillation noise having 2.5 to 3kV peak voltage for 2s 1.5kV square wave (rise time: 1ns, pulse width: 1μs) for 10 minutes continuously	
Vibration resistance	JIS C 60068-2-6 10-58Hz: single amplitude 0.075mm. 58-150Hz=constant acceleration 10m/s <sup>2</sup> X, Y, Z directions 8minutes X10 cycles	
Electrostatic noise resistance	Mounting steel panel surface: ± 8kV F-MPC04 (UM04) front panel surface: ± 15kV	
Permissible momentary power failure	20ms, continuous operation (excluding display)	
Mass	Power monitoring unit UM01: 1000g, CT-BOX: 300g Terminal relay: 200g	

Note \*1 The control power consumption on the table applies to where CT-BOXes and Terminal relays are connected to the power monitoring unit UM04.

# Power Monitoring Equipment

## Power monitoring unit

### F-MPC04

#### • Measurement and display specifications

Measurement type	Effective measuring range	The main body display	Communication data	Accuracy (%)	Remarks
Current: I(r), I(s), I(t)	0, 0.5% to 150% of CT secondary rated current	4 digits	4 digits	±2.5% FS	"0.00" is displayed, if the measured value is about 1.0% or less.
Voltage: *3 V(uv), V(vw), V(wu)	VT secondary voltage: 3Ø3W : max 264V 3Ø4W (Phase voltage): max.264V 3Ø4W (Line voltage): $\sqrt{3}\times 264V$			±2.5% FS	VT secondary voltage is jointly used as internal control power supply. (For U-V)
Zero-phase current I <sub>0</sub>	0, 50 to 3600mA			±20% FS	"0" is displayed, if the measured value is about 50mA or less.
Active power *4*5	0 to 3.5kW (220V) as converted to current transformer secondary value	4 digits with the code	4 digits with the code	±2.5% FS	Two-wattmeter method: Measured when the value is 0.4% or higher of the rated current. (I <sub>r</sub> , I <sub>t</sub> , V <sub>uv</sub> , V <sub>wv</sub> )
Reactive power *4*5	0 to 3.5kvar (220V) as converted to current transformer secondary value			±2.5% FS	Two-wattmeter method
Power factor *4	Lead : 0%-100%-Lag : 0%	3 digits with the code	4 digits with the code	±5% The "90°" phase angle conversion	
Active electric power	0 to 99999 (kWh) The effective power quantity of the plus 0 to 99999 (kWh) The effective power quantity of the minus	5 digits	*6	Equivalent to ordinary class specified in JIS	±2.0% (Power factor of 1 between 5% and 120% of CT primary rated current) ±2.5% (Power factor of 0.5 between 10% and 120% of CT primary rated current)
The reactive energy	0 to 9999 (kvar) The reactive energy of the plus 0 to 9999 (kvar) The reactive energy of the minus				none
The voltage minimum value	"264V from 85V" in VT secondary of each phase	4 digits		±2.5% FS	
The voltage maximum value	"264V from 85V" in VT secondary of maximum-phase			±2.5% FS	
Harmonic current	3rd & 5th order : 0, 2.5% to 150% 7th order : 0, 5.0% to 150%			±2.5% (7th order: ±5%)	*7

Note : \*1. The measurement accuracy includes the error in the CT boxes and ZCT. The error in the combined VTs and CTs are not included.

\*2. Current, voltage, and power performance characteristics are according to JIS C 1102 (indicating electrical measuring instruments). The measurement display value is the average value over approximately 1 second.

\*3. The values in the table are the line voltages for 3-phase, 3-wire systems and the phase voltages for 3-phase, 4-wire systems. For 3-phase, 4-wire applications, the setting in this table can be used to display either the phase voltages or line voltages.

\*4. Selling/purchasing for power measurement and lead/lag for power factor measurements are displayed with one sign (blank for positive). The meaning of positive/negative for each measurement item is given below.

\*5. The maximum values of the active power and reactive power are ±3.5kW at a 5A secondary current for 3-phase, 3-wire systems, ±0.69kW at 1A for 3-phase, 3-wire systems, ±6.0kW at a 5A secondary current for 3-phase, 4-wire systems, and ±1.2kW at a 1A secondary current for 3-phase, 4-wire systems.

\*6. For the F-MPC-Net protocol, the lower four digits of the display are sent. For the MODBUS RTU protocol, 0 to 999999.999kWh is sent and the step value for the total countup depends on the VT ratio and CT ratio.

\*7. For 3-phase, 3-wire systems, the harmonic currents for phases R and T are measured. For 3-phase, 4-wire systems, the harmonic currents for phases R, S, and T are measured.

#### The sign "±" in electric measuring

The sign "±" is used to display "LEAD/LAG" in power-factor, measuring and "electric power selling/purchase" in electric power measuring. No signs are used if a value is "+". The sign "±" has the following meanings depending on the measured items.

- Active power: kW
  - +: Power purchase (Consumed electric power)
  - : Electric power selling (Inverse electric power flow)
- Reactive power: kvar
  - +: Lagging current by reactive volt-ampere meter method
  - : Leading current by reactive volt-ampere meter method
  - \* "LEAD/LAG" reverses with electric power selling/purchase.
- Power factor: COSφ
  - + : LEAD - : LAG

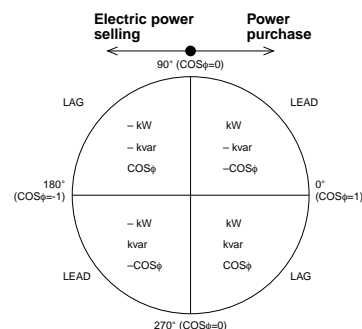

● **Demand measurement**

Item	Specification
Current (I(r), I(s), I(t)) Effective power Zero-phase current (rms:lo, 50/60Hz:lob) Harmonics currents, voltage	Time: Select one from 0, 1 to 15 minutes (1 minute increments) and 30 minutes it at the initial setting (common to all 10 circuits). Display item: 1. Demand values 2. Maximum demands (maximum values recorded before the last reset operation)

● **Specifications of a leakage current relay**

Sensitive current

Setting value	200/500/1000/2000/3000mA or Lock (lo or lob selectable)
Operating Level	50 to 100% of setting value (Operate at less than 50%, no operate at 100%)

Operation time characteristics

Setting time	Inertia non-operating time	Operating time
0.1s	–	100ms max.
0.3s	150ms min.	0.3s max.
0.5s	250ms min.	0.5s max.
1.0s	500ms min.	1.0s max.
3.0s	1,500ms min.	3.0s max.

- Note: • Sensitive current and operation time can be set by an arbitrary combination.  
 • The values on the table is for a trip relay's specifications. The pre-alarm relay operates at half the operating level on the table, and its operation time is 10s fixed. The pre-alarm relay can be used as an alarm against leakage current increase in case of cable insulation deterioration or flood.

● **Data display at fault occurrence**

Pre-alarm of load current, pre-alarm of leakage current relay (auto-reset), maximum current indication at circuit interruption (indication reset by resetting)

● **kWh-pulse-output specifications** (for products with a kWh-pulse-output feature)

Transistor open collector output: 35V DC, 50mA max., (residual voltage at ON state: 2.5V max.)  
 Output pulse width: 200ms ±20ms  
 Output period: 1,000ms min.  
 Output pulse rate: 10<sup>n</sup> kWh/pulse, n = -2, -1, 0, 1, 2, or 3 (selected from VT and CT ratio.)

● **ZCT with Leakage Current Relay**

The UM04 can be used together with a MCCB with ZCT or a zero-phase current transformer.

■ **Communications specifications**

Item	Specifications		
	F-MPC-Net protocol *	MODBUS RTU protocol *	
Standard	EIA-485		
Transmission method	Half duplex, 2-wire		
Data exchange method	1:N (UM04) polling/selecting		
Transmission distance	1,000m (total length)		
Number of stations	31 max. per system (excluding master)		
Transmission speed	4,800/9,600/19,200bps (selectable)		
Address setting	1 to 99		
RS-485 terminal names	DXA, DXB	Connect DXA as D1(+) and DXB as D0(-).	
Transmitted characters	ASCII	Binary	
Data format	Start bits	1 bit (fixed)	1 bit (fixed)
	Data length	7 or 8 bits (selectable)	8 bit (fixed)
	Parity bit	None, even, or odd (selectable)	None, even, or odd (selectable)
	Stop bits	1 bit (fixed)	No parity: 2 bits (fixed) Others: 1 bit (fixed)
	BCC	Even vertical parity	CRC-16

\* The F-MPC-Net or MODBUS RTU protocol can be set for communications for the UM04.

■ **Digital input specifications**

Item	Specification	Remarks
Number of inputs	4	Communications transmissions and UM04 display of ON/OFF status and pulse count.
Exterior input signals	No-voltage contact input or transistor open-collector input	
Input specifications	24V DC, approx. 5mA flow OFF level: 1mA max.	
Minimum input signal width	50ms	

# Power Monitoring Equipment

## Power monitoring unit

### F-MPC04

#### ■ System configuration

With an integrated power monitoring unit UM04, you can easily construct a low-voltage power distribution system equipped with leakage current measuring, leakage current pre-alarm, and earth leakage circuit shutdown.

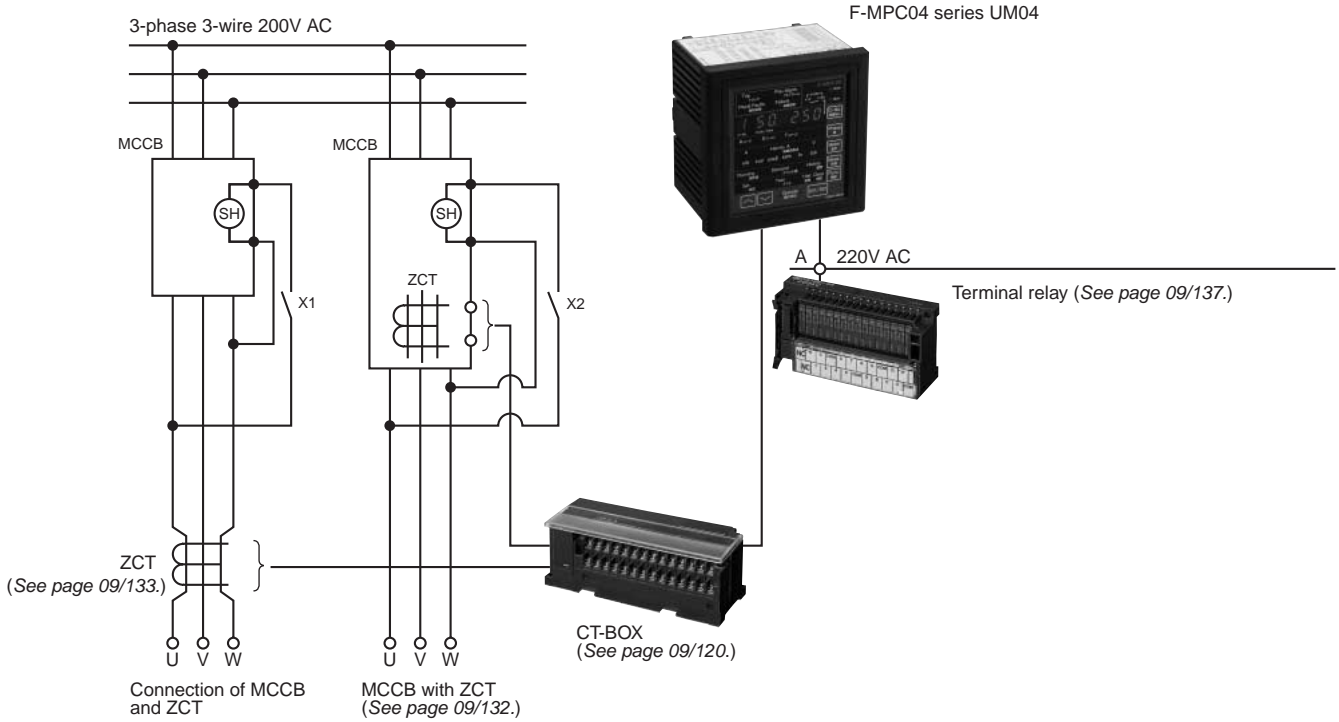

(SH) : Shunt trip device

#### ■ Dimensions, mm

##### • Integrated power monitoring unit, UM04

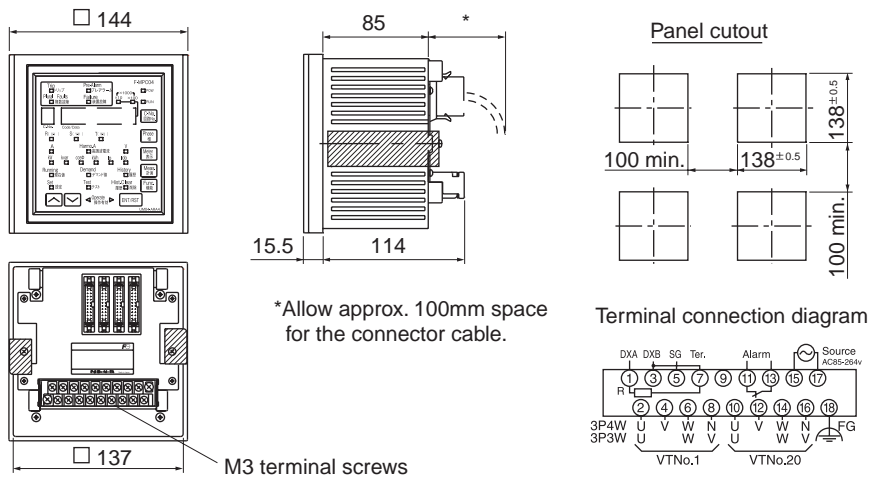

##### • CT-BOX, UM04X

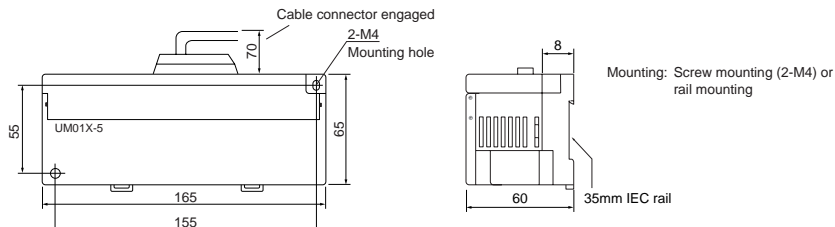

**Multi-circuit power monitoring unit, UM02**

■ **Description**

Integrating measuring functions required for power monitoring in one unit

- A single unit measures multiple circuits  
 A single UM02 can measure up to 8 feeders in 3-phase 3-wire, 12 feeders in single-phase 2-wires and up to 4 feeders in 3-phase 4-wire circuit.
- Easy installation into existing switchboards  
 Compact UM02 can be easily installed into on-site power distribution or lighting panel, irrespective of new panel or existing panel, to create power monitoring system economically.
- On-site measuring instrument  
 UM02 can be used an on-site measuring instrument by combining with an optional display and setting unit UM02X-S.
- Communication interface  
 As UM02 has an RS-485 communications interface as standard, it can communicate with other power monitoring equipment with RS-485

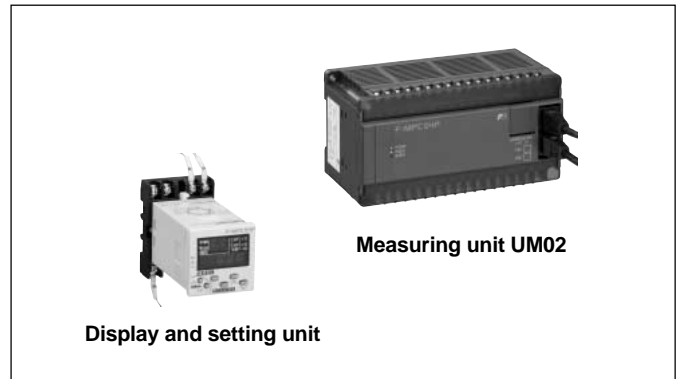

■ **Type number nomenclature**

Multi-circuit power monitoring unit (Measuring unit)

**UM02-AR 3**

**Basic type**

UM02-AR: Measuring unit

**Applicable circuit**

- 2: Single-phase 2-wire, up to 12 feeders
- 3: 3-phase 3-wire, Single-phase 3-wire, Single-phase 2-wire, up to 8 feeders
- 4: 3-phase 4-wire, up to 4 feeders

■ **Type and applicable circuit**

Description	Applicable circuit	Type
Measuring unit	Single-phase 2-wire, up to 12 feeders	UM02-AR2
	3-phase 3-wire, Single-phase 3-wire, Single-phase 2-wire, up to 8 feeders	UM02-AR3
	3-phase 4-wire, up to 4 feeders	UM02-AR4
Sold separately		
Display and setting unit	The TP48X socket and connecting cable are provided as accessories.	UM02X-S
Cable for UM02-AR connection	0.5m	UM02X-C005
	5m	UM02X-C050

# Power Monitoring Equipment

## Power monitoring unit

### F-MPC04P

#### ■ Specifications F-MPC04P (UM02)

##### • General specifications

Item	Specification
Ratings	Voltage Direct input: 100 or 200V AC, 400V AC (AR4 only) VT primary/ secondary: 220, 440V AC, 3.3k, 6.6kV AC/110V AC, 440/220V AC *1
	Current Split CT: 5, 50, 200, 400A AC Small split current sensor CT: 5A AC (primary rated set range 10 to 7500A) *1
Control power supply	100/200V AC common use (85 to 264V AC) AR2: between terminals P1-N, AR3: between terminals U-V, AR4: between terminals P1-P2
Inrush current	15A max., 3ms max. (100V AC 50Hz) 30A max., 3ms max. (200V AC 50Hz)
Control power consumption	20VA or less (or approx. 15VA at 200V AC, 10VA at 100V AC)
Ambient temperature	Operating: -10 to 55°C (no icing or no condensation) Storage: -20 to 70°C (no icing or no condensation)
Humidity	20 to 90% RH (no condensation)
Atmosphere	Free from corrosive gases and excessive dusts or particles
Insulation resistance	10MΩ min. between electric circuits and ground
Dielectric strength	2000V AC, 1 minute (2500V AC, 1 minute for AR4) between control power circuits and ground
Lightning impulse noise resistance	4.5kV (1.2 × 50μs) between control power circuits and ground (6.0kV for AR4)
Momentary overload capability	20 times rated current, 9 times for 0.5s.
Vibration resistance	JIS C 60068-2-6 10 to 58Hz: single amplitude of 0.075mm, 58 to 150Hz, constant acceleration of 10m/s <sup>2</sup> 8 minutes × 10 cycles in each of X, Y, and Z directions
Shock resistance	JIS C 60068-2-27 Half sine wave 300m/s <sup>2</sup> , for 11 ms × 3 times in each of X, Y, and Z directions
Noise immunity	1.5kV square wave (rise time: 1ns, pulse width: 1μs) for 10minutes continuously
Permissible momentary power failure	20ms (continuous operation) except RS-485 communications
Mass	Measuring unit: Approx. 500g, Display and setting unit: Approx. 200g

Note \*1 Make VT and CT ratio settings through the display and setting unit UM02X-S or from the host controller.

##### • Measurement specifications

Item	Effective measurement range	Display	Accuracy *1	
Current (N-phase current measured in AR4)	With split CT (200A and 400A AC) combined 0, 0.4% of In to 500A	4 digits	±1.5%	
Active power	With small split current sensor (50A AC) combined 0, 0.4% of In to 50A			
Reactive power *2	with small split current sensor (5A) combined *4	□. □□	±2.5% for S-phase current of AR3 and N-phase current of AR4	
Power-factor	0 to n times CT rating	□. □□	±5% (converted into a phase angle of 90°)	
Active electric energy *2		5 digits	Equivalent to JIS ordinary class *4	
Max. active power *3	Same as above. (with a demand time set to 0, 1, 5, 10, 15, or 30min.)	4 digits	±1.5%	
Min. voltage each phase *2	AR2, R3 85 to 264V (directly or VT secondary voltage conversion) The minimum and maximum voltage are average values for 0.3s.	AR4 Phase voltage 50 to 288V (directly or VT secondary voltage conversion) Line voltage 86 to 498V The minimum and maximum voltage are average values for 0.3s.	4 digits	±1.5%
Max. voltage *2			±1.5%	

Notes \*1 Measurement accuracy does not include CT and current sensor.

\*2 In measurement mode display is the number of digits of RS-485 communications data. The display and setting unit does not display communications data on reactive power, minimum voltage, and maximum voltage values.

\*3 Max active power and active electric energy values can be reset by the display and setting unit and host controller. And, when VT ratio or CT ratio is changed, these are automatically reset.

\*4 With 1-turn or 3-turn primary winding selected for the 5A small split current sensor, the lower limit of minute current measurement is selected as specified below.

Classification	Measurement and display range	Measurement lower limit (Electric energy starting current)	Accuracy	
			Current and power	Electric energy
1 turn	0, 2% to rating × 10	2% of rating	0 to rating: ±1.5% of rating	±2.5% (5% to 100% of rating, load power factor -0.8 to 1.0 to +0.8)
3 turns	0, 0.7% to rating × 3	0.7% of rating	Exceeding rating: ±1.5% (FS)	

Note: \* Sampling interval/measurement display value (communication) of current and power, and sampling and integration intervals of electric energy are shown below. In the case of an intermittent load, such as a welding machine, accurate measurement may be disturbed and therefore the use of the single-circuit F-MPC04S (refer to page 118) is recommended.

• **Sampling interval and display value**

Type	Sampling interval/display value of current and power (Communication)	Sampling and cumulative interval of power
UM02-AR2	Approx. 0.2s / Average voltage for aprox. 1.5s	Approx. 0.2s
UM02-AR3	Approx. 0.2s / Average voltage for aprox. 1.5s	Approx. 0.2s
UM02-AR4	Approx. 0.1s / Average voltage for aprox. 0.4s	Approx. 0.1s

■ **Display and setting unit UM02X-S, specifications**

Item	Specification	Remarks
Control power supply	Supplied from the measuring unit UM02-AR	
Measuring unit UM02-AR communications specifications	EIA-485 (always 19200bps fixed)	
Number of connectable measuring unit UM02-AR	5 max.	UM02-AR2, AR3, AR4
Max. cable length between UM02-AR and UM02X-S	23m	Total length between UM02X-S and all UM02-ARs
Display item	Operating status, measurement value VT, CT setting value, fault	Selective indication by a switch
Setting	Voltage, current (CT), demand time, pulse multiplication rate, No. of turns of CT secondary winding, host controller communications mode (different communications interface)	UM02-AR incorporates a different RS-485 interface to communicate with a host controller.

Note : The display and setting unit UM02X-S provides a function to start initial communications to recognize the UM02-AR automatically when UM02X-S is turned on. If on-site indication is not necessary once the setting to the measuring unit UM02-AR is complete, UM02-AR fully operates even without UM02X-S.

■ **Communications specifications**

Item	Specification	
Standard	EIA-485	
Transmission system	2-wire half duplex	
Data exchange	1: N (F-MPC04P, UM02-AR) polling/selecting	
Transmission distance	1000m (total length)	
No. of connectable units	Max.32 (including master)	
Station number setting	01 to 99 (set with digital switch)	
Transmission characters	ASCII	
Transmission speed	4800, 9600, or 19200 bps (selectable)	
Data format	Number of start bits	1 (fixed)
	Data length	7 or 8 bits (selectable)
	Parity bit	None, even, or odd (selectable)
	Number of stop bits	1 (fixed)
	BCC	Even horizontal parity

Note : Use the display and set unit to change the transmission setting. The communications specifications cannot be changed through the host controller.

# Power Monitoring Equipment

## Power monitoring unit

### F-MPC04P

#### ■ Dimensions, mm

#### ● Measuring unit UM02-AR

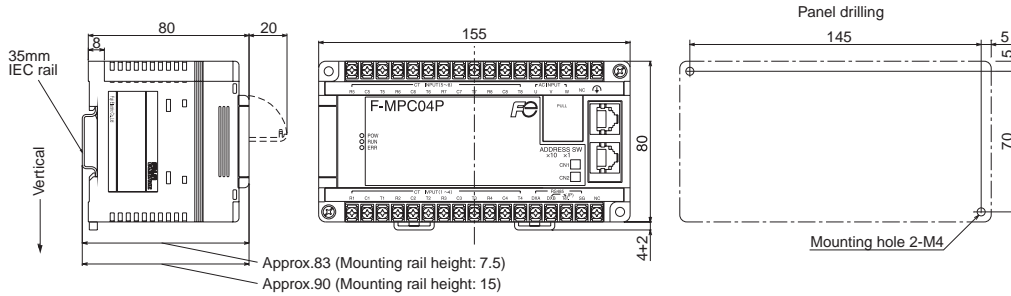

#### ● Display and setting unit UM02X-S

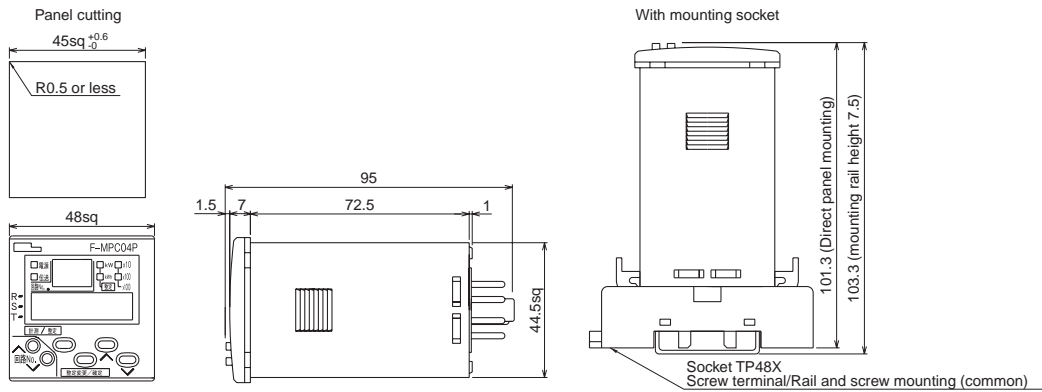

#### ■ System configuration

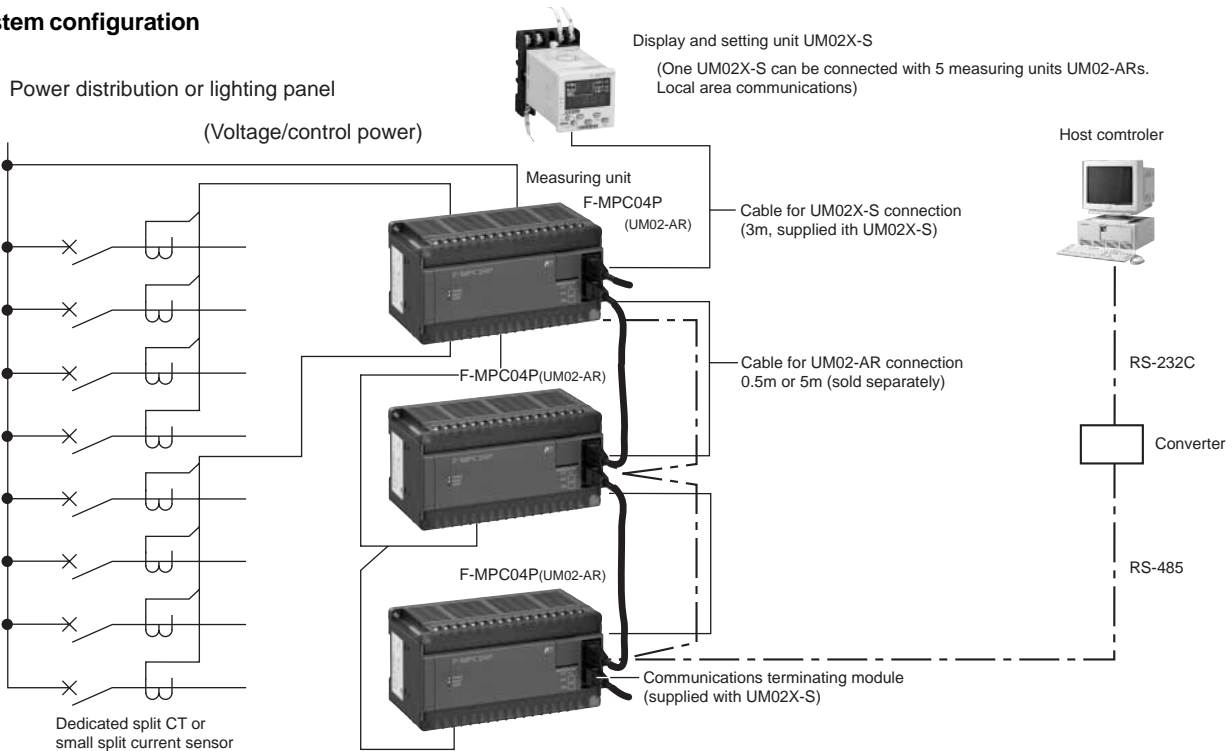

Note: \* The display and setting unit UM02X-S is a local area communications master and can monitor and be able to set maximum five measuring units, UM02-ARs.

\*\* Station address setting of measuring unit UM02-AR

Use a digital switch on the measuring unit to set a different station address (communication address to host controller).

In local area communication of the display and setting unit UM02X-S, the UM02X-S will automatically read out the address of the measuring units connected with cables for unit connection, and communicate with them.

### Single circuit power monitoring unit, UM03

#### ■ Description

Integrating measuring functions required for power monitoring in one unit

#### ● Output functions for preventive maintenance selectable

- Power alarm/current prealarm
- kWh pulse output
- Leakage current alarm, leakage current prealarm output (model with leakage current measuring function) only

#### ● Capable of measuring inrush current of welders

- High-speed sampling and calculation of voltage and current

#### ● Compact design allows installation almost anywhere.

- Space-saving construction simplifies installation.
- Suited for monitoring individual equipment, section, and floor

#### ● Networking capability

- RS-485 interface.
- Can be connected to power distribution system same way as the power monitoring equipment F-MPC 60B, 30, 04 (UM04, UM02) series products

#### ■ Type numbers

Single circuit power monitoring unit		Type
Leakage current measuring function	Not provided	<b>UM03-ARA3</b>
	Provided	<b>UM03-ARA3G</b>

Note : As CTs, use type numbers CC2D81-0057, CC2D81-0506, CC2D65-2008, CC2D54-4009, CC2B65-2008, and CC2B54-4009. Refer to page 134. General-purpose CTs (secondary rated current 5A or 1A) cannot be connected directly. Use the general-purpose CT (5A) together with type number CC2D81-0057. Use dedicated ZCT as combination ZCT with the UM03-ARA3.

#### ■ Specifications

##### • General specifications

Applicable circuit	Single circuit 3-phase 3-wire: 2-CT, single-phase 3-wire: 2-CT, single-phase 2-wire: 1-CT	
Control power supply	100 to 200V AC (85 to 264V AC) 50/60Hz (45 to 66Hz)	
Inrush current	15A, 3ms or less (at 110V AC, 50Hz) 30A, 3ms or less (at 220V AC, 50Hz)	
Control power consumption	Approx. 7VA (at 220V AC) Approx. 5VA (at 110V AC)	
VT consumed burden	Approx. 0.2VA	
Continuous overload capability	Current input circuit	110% of maximum setting value (150% of rated current), 2 hours
	Voltage input circuit	291V AC (1.1×264V AC), 2 hours
Short-time overload capability	Current input circuit	2000% of max. setting value (150% of rated current), 9 times for 0.5s
	Voltage input circuit	200% of max. setting value (264V AC), 9 times for 0.5s
Vibration	10 to 58Hz	0.075mm (one-way amplitude)
	58 to 150Hz:	constant acceleration 10m/s <sup>2</sup> , 10 cycles for 8 min in each X, Y, and Z directions
Shock	300m/s <sup>2</sup> , in each X, Y, and Z directions, 2 times	
Withstand voltage / Insulation resistance (500V DC megger)	2kV /10MΩ	Between power supply terminals connected together and other terminals connected together
	2kV /10MΩ	Between measurement input terminals connected together and other terminals connected together
	2kV /10MΩ	Between alarm output terminals connected together and other terminals connected together
	500V /10MΩ	Between watthour pulse output terminals connected together and other terminals connected together
Ambient temperature	-10 to +55°C	
Storage temperature	-20 to +70°C	
Humidity	20 to 90%RH (no condensation)	
Atmosphere	Free from corrosive gases and excessive of dusts	
Grounding	Type D ground (100 Ω or less)	
Allowable momentary power failure time	20ms (operation will continue)	
Altitude	2,000m or less	
Mass	Approx. 400g (main unit only, CT excluded)	



#### ■ System configuration

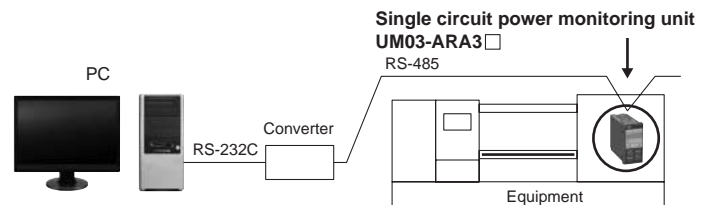

# Power Monitoring Equipment

## Power monitoring unit

### F-MPC04S (UM03)

#### • Measurement specifications

Item	Effective measurement range	Display	Accuracy *1
Current (R/S/T), demand current Max. demand current value	• With CT (200A AC) 0, 0.4% of In (0.8A) to 300A	4-digit	±1.5%: R- and T-phase ±2.5%: S-phase
Demand value and max. demand value of total harmonic current *2	• With CT (400A AC) 0, 0.4% of In (1.6A) to 600A	4-digit	± 2.5%
Active power (±) Demand power Max. active demand power value	• With CT (5A) 0, 0.4% of In (0.2A) to 50A 0, to 1.5 times CT rating (for 5A)	4-digit	±1.5%
Reactive power (±)	(converted into CT secondary: 7.5A)	4-digit	±3%
Power factor (±)	(Max. display range: up to 9,999A)	3-digit	±5% (Converted into a phase angle of 90°)
Active electric energy (+only)	• Demand time setting: 0, 1 to 15min	5-digit	Equivalent to JIS ordinary class (pf: 0.5-1.0- -0.5)
Reactive electric energy (±absolute value addition)	(by 1min step) 30min setting: Available	5-digit	±5%
Voltage	Converted into an input voltage 60 to 264 V AC	4-digit	±1.5% ±2.5%: Vv-w
Frequency *3	45 to 66Hz *2	3-digit	±0.5%
Leakage current (Io/Iob) *4 Max. demand value	0, 10 to 1000mA	4-digit	±2.5%

Note: \*1 The measurement accuracy is a value for FS (full span).

\*2 The total harmonic current relates only to phase R and phase T. Only the demand value and max demand value are displayed. The current value is not displayed.

\*3 If the frequency is out of the measurement range (lower than 45 Hz or higher than 66 Hz), 0.0 [Hz] is displayed.

\*4 Measurement of leakage current is possible only with UM03-ARA3G.

#### • Output specifications

Item	UM03-ARA3	UM03-ARA3G	Specification
Watt-hour pulse output	Provided	Provided	Transistor open collector output 35V DC 100mA
Alarm output	Current prealarm (OCA), power alarm *	Provided	Replay output 250V AC 1A
	Leakage current prealarm (OCGA) (Io operation)	Not Provided	
	Leakage current alarm (OCG)	Not Provided	

Note: \* Choose the current prealarm (OCA) output or power alarm by change of setting.

#### Watt-hour pulse output details

Output specifications	35V DC 100mA (residual 2.5V or less at ON)
Output pulse width	100ms±20ms
Output interval	200ms or more
Pulse multiplication rate	10 <sup>n</sup> kWh/pulse (n=-3 to 2 setup)

#### Alarm output details

	Setting range		Accuracy	
	Operate value	Time	Operate value	Time
Current prealarm (OCA) *1	I: 20 to 120% of rated value, Lock (5% step)	Depending on the demand time setting	±5% (rated min ±1.5%)	±10%
Power alarm *1	0 to 9999kW (1kW step)			
Leakage current alarm (OCG) (Io operation)	Operate current 100, 200, 500mA, Lock	0.1, 0.3, 0.5, 1.0s	75%±5% of setting value	75%±5% of setting value (min±25ms)
Leakage current prealarm (OCGA)	50±5mA 100 to 500mA (50mA step), Lock	0.1, 0.3, 0.5, 1.0, 10s or demand time *2	±5%	±5%

Note: \*1 Select either the current pre-alarm output or the power alarm output through setup.

\*2 When demand time is selected, the unit operates on Iob (leakage current only with fundamental wave).

■ **Communications specifications**

Item	Specification	Factory setting
Standard	EIA-485	—
Transmission system	2-wire half duplex	—
Data exchange	1: N polling/selecting	—
Transmission distance	1000m (total length)	—
No. of connectable units	max.32 (including master)	—
Station number setting	1 to 99	Without station number setup
Transmission characters	ASCII	—
Transmission speed	4800, 9600, or 19200 bps (selectable)	19200 bps
Data format	Number of start bits	1 (fixed)
	Data length	7 or 8 bits (selectable)
	Parity bit	None, even, or odd (selectable)
	Number of stop bits	1 (fixed)
	BCC	Even horizontal parity

■ **Front panel**

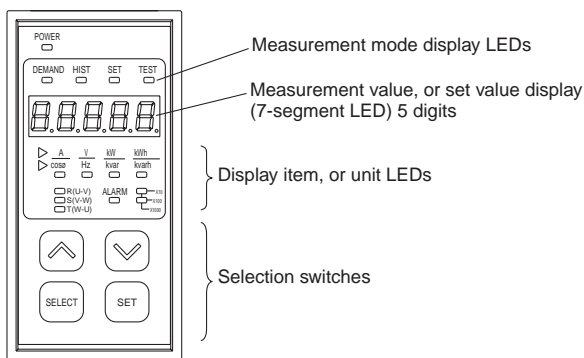

• **Terminal layout**

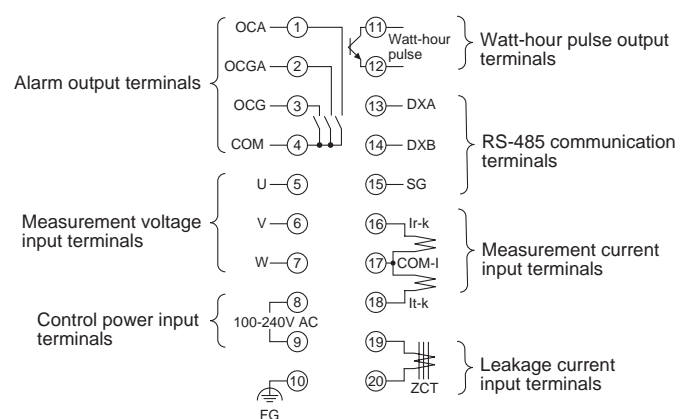

Note: Alarm output terminal ② ③ and ZCT input terminal ⑲ ⑳ of the UM03-ARA3 (without leakage current measuring function) are NC terminals. Do not connect anything to these terminals.

■ **Dimensions, mm**

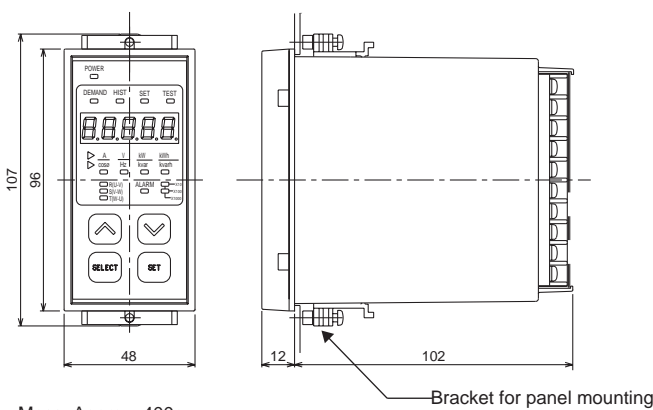

Panel cutting

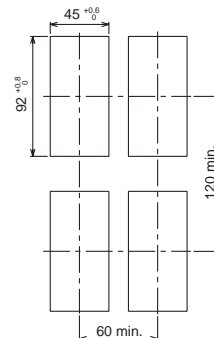

# Power Monitoring Equipment

## MCCB with ZCT and zero-phase CT

### Molded case circuit breakers with ZCT

#### ■ Description

A leakage current monitoring and breaking system can be easily constructed by combining one of the following models with a UM04 integrated power monitoring unit or a UM03-ARA3G single-circuit power monitoring unit with leakage current measurement.

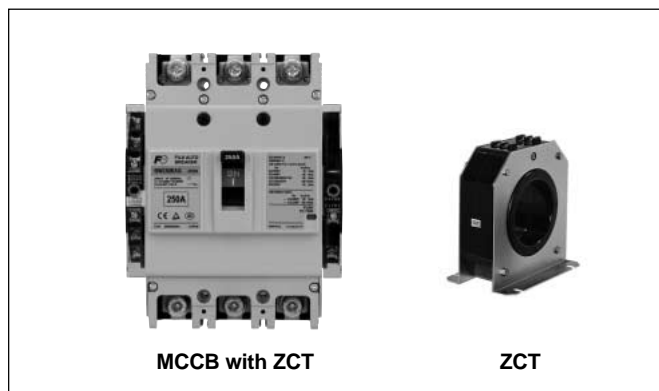

#### ■ Specifications, MCCB with ZCT for line protection

Frame (AF)	125		250		400		630		800	
Type	<b>BW125JAZ</b>	<b>BW125RAZ</b>	<b>BW250JAZ</b>	<b>BW250RAZ</b>	<b>BW400JAZ</b>	<b>BW400RAZ</b>	<b>BW630RAZ</b>	<b>BW800RAZ</b>		
Number of poles and number of elements	3P3E		3P3E		3P3E		3P3E		3P3E	
Rated insulation voltage $U_i$ [V]	AC 690		690		690		690		690	
Rated impulse withstand voltage $U_{imp}$ [kV]	6		6		6		6		6	
Rated current $I_n$ [A]	15,20,30,40,50,60,75,100,125		125,150,160,175,200,225,250		250,300,350,400		500,600,630		700,800	
Reference ambient temperature: 40°C										
Rated frequency [Hz]	50-60		50-60		50-60		50-60		50-60	
Rated breaking capacity [kA]	AC 440/415/400/380V		30	50	30	50	36	50	50	50
JISC8201-2-1 Ann2 [Icu]	AC 240/230V		50	100	50	100	85	100	100	100
Isolation complaint	Compliant		Compliant		Compliant		Compliant		Compliant	
Reverse connection	Possible		Possible		Possible		Possible		Possible	
Utilization category	Cat.A		Cat.A		Cat.A		Cat.A		Cat.A	
Dimensions [mm]										
	a	115	130		178		248		248	
	b	155	165		257		275		275	
	c	68	68		103		103		103	
	d	95	95		146		146		146	
Mass	1.5		2		6.2		9.5		10	
Connection method	Front		(screw terminals)		(screw terminals)		(flat terminals)		(flat terminals)	
Standard	Auxiliary switch	W	●		●		●		●	
Internal	Alarm switch	K	●		●		●		●	
accessories *1	Trip device	F	●*3		●*3		●*3		●*3	
	Test terminal	T <sub>1</sub> , T <sub>2</sub>	●		●		●		●	
	ZCT output	Z <sub>1</sub> , Z <sub>2</sub>	●		●		●		●	
Certified standards	Certified standards	Specified Electrical Appliance and Material *2	Not applicable.		Not applicable.		Not applicable.		Not applicable.	
	JISC8201-2-1	Self declaration								
	IEC60947-2	—								
	EN60947-2 (CE marking)	—								
Overcurrent tripping method	Thermal-magnetic		Thermal-magnetic		Thermal-magnetic		Thermal-magnetic		Thermal-magnetic	
Trip button	Provided		Provided		Provided		Provided		Provided	

●: Available

\*1 The auxiliary switch, alarm switch, and tripping device are provided as accessories. Only models with terminal blocks are available. Lead wires are not provided.

\*2 Not applicable for a rated current of 125A.

\*3 Specify 100 to 120V AC/100 to 110V DC or 200 to 240V AC/200 to 220V DC for the voltage rating.

\*4 The voltage rating is 100 to 240V AC/100 to 220V DC for all models.

■ Internal wiring

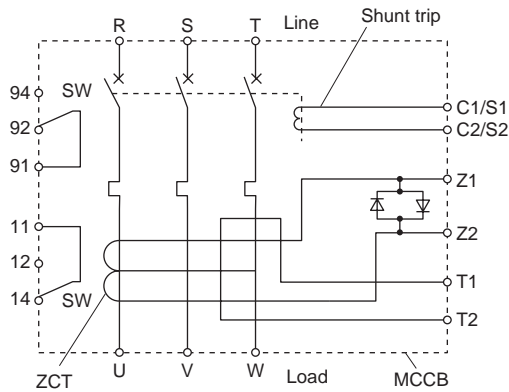

\*S1, S2 : Shunt trip coil input terminal  
\*Z1, Z2 : ZCT output terminal  
\*T1, T2 : ZCT trip test current input terminal

■ EW series zero-phase current transformers (low-voltage circuit use)

Description	Type	Rated current (A)	Sensor hole diameter (mm)	Hole-through cable			Mass (kg)
				1φ2W	1φ3W, 3φ3W	3φ4W	
Round hole through-type	EW-ZB-30M05	50	30	IV 14mm <sup>2</sup>	IV 8mm <sup>2</sup>	IV 8mm <sup>2</sup>	0.22
	EW-ZB-30M1	100	30	IV 60mm <sup>2</sup>	IV 50mm <sup>2</sup>	IV 38mm <sup>2</sup>	0.32
	EW-ZB-58M2	200	58	IV 125mm <sup>2</sup>	IV 100mm <sup>2</sup>	IV 80mm <sup>2</sup>	0.6
	EW-Z70A4	400	70	IV 400mm <sup>2</sup>	IV 325mm <sup>2</sup>	IV 250mm <sup>2</sup>	1.1
	EW-Z70A6	600	70	IV 400mm <sup>2</sup>	IV 325mm <sup>2</sup>	IV 250mm <sup>2</sup>	1.1
	EW-Z90	800	90	IV 500mm <sup>2</sup>	IV 500mm <sup>2</sup>	IV 500mm <sup>2</sup>	3.1
	EW-Z115	1200	115	—	—	—	4.8
	EW-Z160	2000	160	—	—	—	10
Split through-type	EW-Z250	3000	250	—	—	—	28.5
	EW-ZD30	100	30	IV 60mm <sup>2</sup>	V 50mm <sup>2</sup>	IV 38mm <sup>2</sup>	0.55
	EW-ZD45	200	45	IV 125mm <sup>2</sup>	V 100mm <sup>2</sup>	IV 80mm <sup>2</sup>	0.89
	EW-ZD65	400	65	IV 325mm <sup>2</sup>	V 250mm <sup>2</sup>	IV 200mm <sup>2</sup>	1.15

Description	Type	Rated current (A)	Sensor hole diameter (mm)	Hole-through conductor		Mass (kg)
				3φ3W	3φ4W	
With conductors, 3-pole	EW-Z3B40	400	70	5×40mm	—	2.8
	EW-Z3B50	500	70	6×40mm	—	3.1
	EW-Z3B60	600	90	6×50mm	—	7.6
	EW-Z3B80	800	90	8×50mm	—	8.8
	EW-Z3B100	1000	90	12×50mm	—	11.5
	EW-Z3B120	1200	115	10×75mm	—	15.2
	EW-Z3B160	1600	160	12×100mm	—	30.5
	EW-Z3B200	2000	160	6×100mm×2	—	30.5
With conductors, 4-pole	EW-Z3B300	3000	250	8×150mm×2	—	68.6
	EW-Z4B40	400	90	—	5×40mm	6.4
	EW-Z4B50	500	90	—	6×40mm	6.9
	EW-Z4B60	600	90	—	6×50mm	11.5
	EW-Z4B80	800	90	—	8×50mm	14.1
	EW-Z4B100	1000	115	—	12×50mm	15.5
	EW-Z4B120	1200	115	—	10×75mm	24.9
	EW-Z4B160	1600	160	—	12×100mm	36.4
EW-Z4B200	2000	160	—	6×100mm×2	36.4	
EW-Z4B300	3000	250	—	8×150mm×2	80.3	

Note : Twist the ZCT secondary wires (normally once every 50mm) and separate the wires from power line.

# Power Monitoring Equipment

## Current transformers

### CC2

#### Current transformers, CC2

##### ■ Description

Designed for even easier handling. Line-up consists of two types; models exclusively used for FUJI power monitoring unit (F-MPC 04 series), and models for general-purpose instrumentation.

- Improved design enables easier mounting.
- Large K → L display allows easier identification of primary conductor direction.
- Hook attached makes it easier to secure the primary conductor with a cable-tie.
- Clamping diode built in CT will not burn out even with the secondary circuit open (except for the CC2D81).

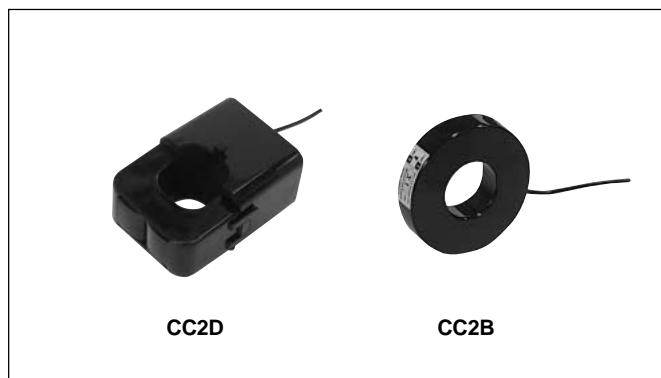

##### ■ Specifications

- CTs are dedicated CTs. General-purpose CTs (secondary rated current 5A or 1A) cannot directly be connected because there is a risk of damage.

##### CT for F-MPC04P (type number UM02), and F-MPC04S (type number UM03)

Model	Compact split		Square split		Toroidal	
Type	CC2D81-0057	CC2D81-0506	CC2D65-2008	CC2D54-4009	CC2B65-2008	CC2B54-4009
Dimensions	Fig.1	Fig.1	Fig.2	Fig.3	Fig.4	Fig.5
Rated primary current	5A	50A	200A	400A	200A	400A
Linear output limit	Depends on the measurement range of the main unit.					
Rated secondary current	7.34mA	73.4mA	66.67mA	133.33mA	66.67mA	133.33mA
Through hole diameter	ø10		ø24	ø36	ø24	ø36
Rated frequency	50 to 60Hz		50 to 60Hz			
Overcurrent strength	10In continuous	1.0In continuous	1.0In continuous			
Ratio error	±1%/In ±1.5%/0.2In					
Phase difference	150'±90'/In, 180'±120'/0.2In		±60'/In, ±90'/0.2In			
Rated burden	0.2693mVA (5Ω load resistance)		44.4mVA (10Ω load resistance)	0.18VA (10Ω load resistance)	44.4mVA (load resistance of 10Ω or less)	177.8mVA (load resistance of 10Ω or less)
Insulation resistance	500VDC/100MΩ or more (between sensor core and output lead wire)				500VDC/100MΩ or more (between through hole and output lead wire)	500VDC/100MΩ or more (between through hole and output terminal)
Dielectric strength	2000VAC/min (between sensor core and output lead wire)				2,500VAC/min (between through hole and output lead wire)	2,500VAC/min (between through hole and output terminal)
Output protection	—		3Vp built-in clamp diode	±3Vp built-in clamp diode	—	
Operating conditions	-20 to 75°C, 80%RH or lower (No condensation)		-20 to 75°C, 80%RH or lower (No condensation)			
Split portion securing method	Clamp		Clamp		—	
Mounting method	Hanger		Hanger			
Connection	Heat-resistant IV cable 0.3mm <sup>2</sup> x 1,000mm		Heat-resistant IV cable AWG18, 1,000mm		PVC cable 0.3mm <sup>2</sup> x 1,000mm	M3 screw terminal
Mass	45g		200g	300g	60g	180g

■ Specifications

CT for F-MPC04 (type number UM04)

Model	Square split			Toroidal split	
Type	CC2D74-1001	CC2D74-2001	CC2D74-4001	CC2C76-8001	CC2C76-12X1
Dimensions	Fig.3			Fig.6	
Rated primary current	100A	200A	400A	800A	1,200A
Linear output limit	Depends on the measurement range of the main unit.				
Rated secondary current	1A				
Through hole diameter	ø36			ø60	
Rated frequency	50 to 60Hz				
Overcurrent strength	1.0In continuous				
Ratio error	±1%/In ±1.5%/0.2In			±1%/In ±1.5%/0.2In ±3%/0.05In	
Phase difference	90±90'/In	60±60'/In	±80'/In	±80'/In, ±100'/0.2In	
Rated burden	0.5VA (0.5Ω load resistance)				
Insulation resistance	500VDC/100MΩ or more (between sensor core and output lead wire)			500VDC/100MΩ or more (between through hole and output)	
Dielectric strength	2000VAC/min (between sensor core and output lead wire)			2500VAC/min (between through hole and output)	
Output protection	±1.4Vp with built-in clamp diode				
Operating conditions	-20 to 75°C, 80%RH or lower (No condensation)				
Split portion securing method	Clamp				
Mounting method	Hanger				
Connection	Heat-resistant IV cable AWG18, 1,000mm			Vinyl cabtire cable 0.75mm <sup>2</sup> x 1,000mm 2-core	
Mass	300g			500g	
Combination CT-BOX	UM04X-1			UM04X-1	

- Note:
- To cope with extension of CT output wire, CT with connector and relay cable are available.
  - For CTs without built-in output protection diode, be sure to draw a primary current after connecting a rated load. Drawing a primary current without connecting the rated load is dangerous because high voltage appears at the output terminal.
  - CT-BOX to be used together with general-purpose CT (10 to 7500A/5A) is the UM04X-5.

# Power Monitoring Equipment

## Current transformers

### CC2

#### ■ Dimensions, mm

Fig1 CC2D81

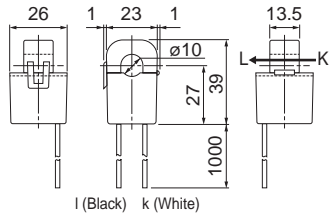

Fig2 CC2D65

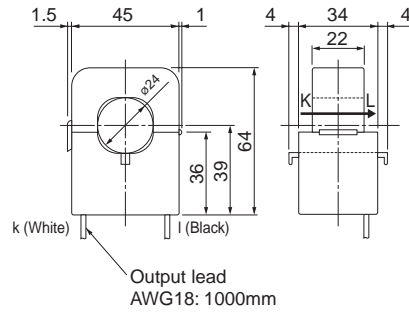

Fig3 CC2D54, CC2D74

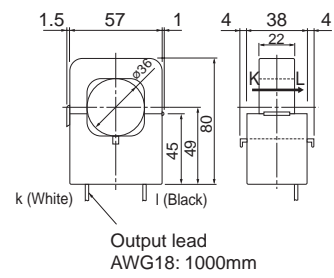

Fig4 CC2B65

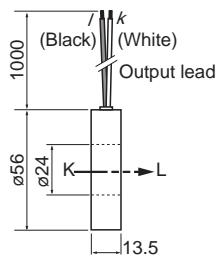

Fig5 CC2B54

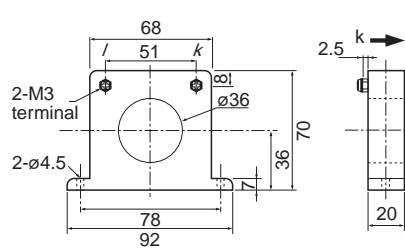
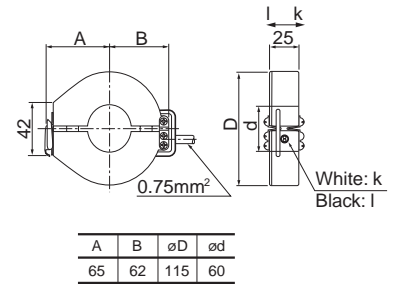

Fig6 CC2C76



## Terminal relay RS16

### ■ Description

The RS16 relay, in combination with F-MPC04 (type: UM01) power monitoring unit, outputs the current prealarm signal and leakage current pre alarm signal, and the signal to trip circuit breakers.

### ■ Specifications

Type	<b>RS16-DE04H</b>	
No. of connectable circuits	5	
Operate time	10ms or less	
Release time	10ms or less	
Vibration	Malfunions durability	10–55Hz 1mm double amplitude (0.61N max.)
	Mechanical durability	10–55Hz 1mm double amplitude (0.61N max.) 3 times in each X, Y, Z direction, total 18 times
Shock	Malfunions durability	100m/s <sup>2</sup>
	Mechanical durability	200m/s <sup>2</sup> , 2 hours in each X, Y, Z direction, total 6 hours
Operating ambient temperature	-25 to 55°C (no icing or no condensation)	
Operating ambient humidity	35 to 85%RH	
Terminal screw size	M3	
Tightening torque	0.5–0.7N • m	
Mounting	Rail mounting (screw mounting also available)	
Applicable crimp terminal	R1.25–3 (Max 6mm)	
Applicable wire size	Max. 1.4mm dia.	
LED color	Operation indication	Red
	Power source indication	Green
Coil surge suppressor	Diode	
Max. No. of rely insertion	50	
Insulation resistance (initial)	100MΩ (500V DC megger)	
Dielectric strength	Between contact and coil	2000V AC, 1 minute
	Between same polarity contacts	1000V AC, 1 minute
	Between reverse polarity contacts	2000V AC, 1 minute
	between heteropolar coils	500V AC, 1 minute
Mass	200g	

### ■ Dimensions, mm

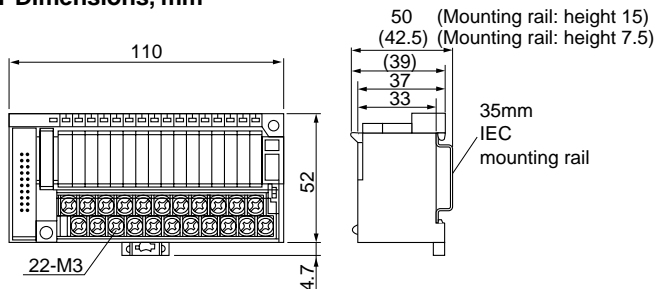

### ■ Connector cable

For connecting CT-BOX, Terminal relay RS16, and Connector terminal block AU-CW.

1m long	AUX014-201
2m long	AUX014-202
3m long	AUX014-203

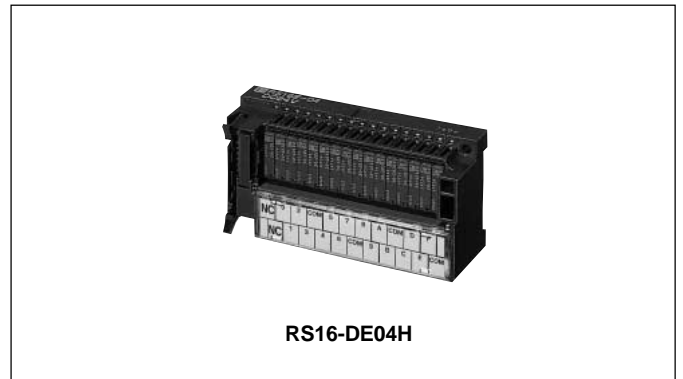

### ■ Terminal arrangement

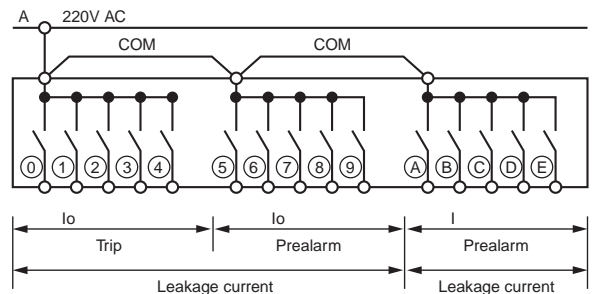

3-phase 3-wire	3-phase 4-wire
① :lo trip (No.1 or 6)	lo trip (No.1 or 4)
② :lo trip (No.2 or 7)	lo trip (No.2 or 5)
③ :lo trip (No.3 or 8)	lo trip (No.3 or 6)
④ :lo trip (No.4 or 9)	Unused
⑤ :lo trip (No.5 or 0)	Unused
⑥ :lo prealarm (No.1 or 6)	lo prealarm (No.1 or 4)
⑦ :lo prealarm (No.2 or 7)	lo prealarm (No.2 or 5)
⑧ :lo prealarm (No.3 or 8)	lo prealarm (No.3 or 6)
⑨ :lo prealarm (No.4 or 9)	Unused
⑩ :lo prealarm (No.5 or 0)	Unused
A :l prealarm (No.1 or 6)	l prealarm (No.1 or 4)
B :l prealarm (No.2 or 7)	l prealarm (No.2 or 5)
C :l prealarm (No.3 or 8)	l prealarm (No.3 or 6)
D :l prealarm (No.4 or 9)	Unused
E :l prealarm (No.5 or 0)	Unused
F :Unused	Unused

### Panel drilling

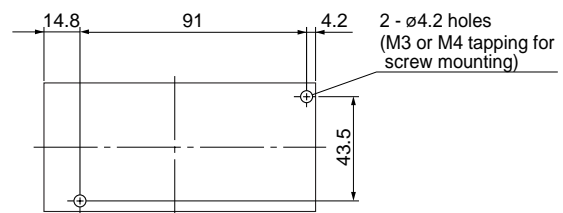

# Power Monitoring Equipment

## Connector terminal-block

### AU-CW21B1

#### Connector terminal-block, AU-CW21B1

##### ■ Description

The AU-CW21B connector terminal-block, in combination with the FMPC04 (type: UM04) power monitoring unit, can output a kWh pulse.

##### ■ Specifications

Type	Front mounting	<b>AU-CW21B1-04</b>
	Rear mounting	<b>AU-CW21B1-04R</b>
Insulation voltage	60V AC/DC	
Continuous current	1A (at 40°C)	
No. of terminals	21	
No. of connectors	20	
Terminal screw size	M3.5	
Insulation resistance	100Ω or more	
Dielectric strength	500V 1min	
Allowable ambient temperature	-5 to +40°C	
Allowable ambient humidity	45 to 85%RH	
Flame resistance	UL94-V1	
Connection cable	Multi-core cable	AUX014-20□ *
	Flat cable	AUX024-20□ *

Note: \* Specify cable length by replacing □ with 1: 1m, 2: 2m, or 3: 3m.

##### ■ Terminal arrangement and output

Terminal No.	Pulse output circuit No.	Remarks
23	Circuit 1 pulse output	Circuit 1 to 6 pulse outputs are valid in 3-phase 4-wire system.
22	Circuit 2 pulse output	
21	Circuit 3 pulse output	
20	Circuit 4 pulse output	
19	Circuit 5 pulse output	
18	Circuit 6 pulse output	
17	Circuit 7 pulse output	
16	Circuit 8 pulse output	
10	Circuit 9 pulse output	
9	Circuit 10 pulse output	
15, 2	Common (-)	

##### ■ Dimensions, mm

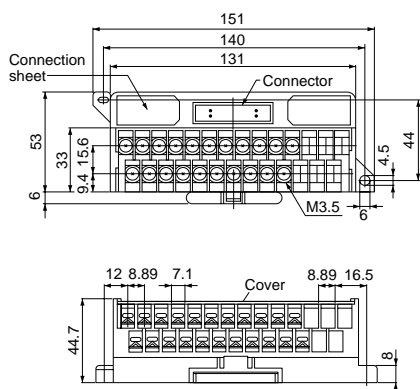

##### ■ Ordering information

Specify the following:

1. Type number

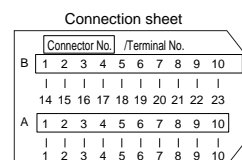
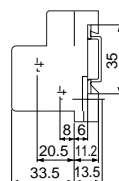
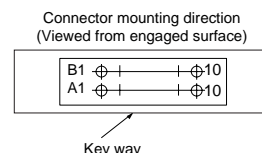

Mounting: Screw or 35mm IEC rail mounting