

FUJI Power Semiconductors

IGBT Modules

IGBT 6-pack/4-pack

Page 1

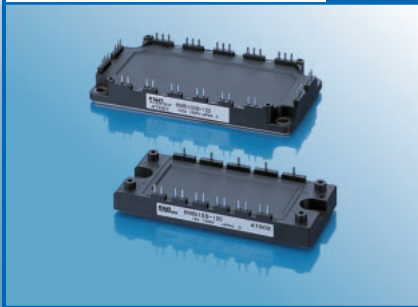

IGBT High Power 6-pack

Page 3



IGBT PIM

Page 4



IGBT Standard 2-pack/1-pack

Page 7



IGBT IPM

Page 10

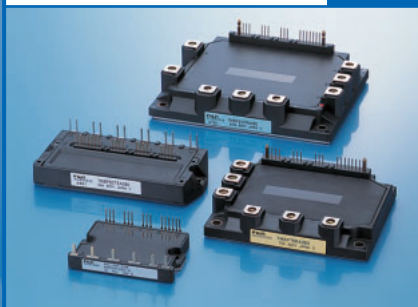

IGBT Discrettes

Page 12

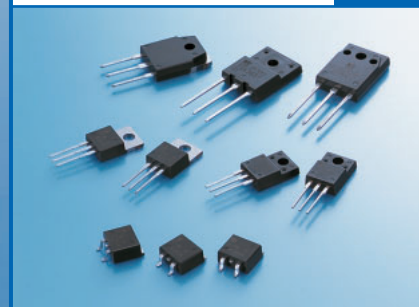

IGBT 6-pack/4-pack

mm

Ic

600V

1200V

**Gen. 3, Gen. 4
Planar-PT**

**Gen. 4
Planar-NPT**

**Gen. 4
Planar-NPT**

1

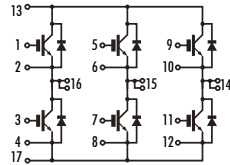
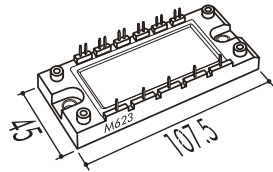

10A
15A
25A
35A
50A

6MBI10S-120
6MBI15S-120
6MBI25S-120
6MBI35S-120
6MBI50S-120

2

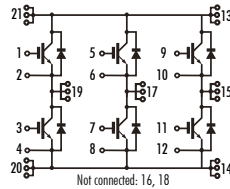
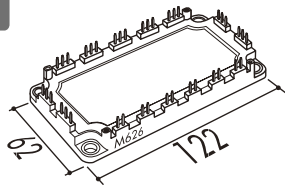

75A
100A

6MBI75S-060
6MBI100S-060

6MBI75S-120
6MBI100S-120

3

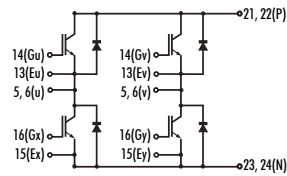
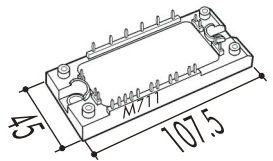

75A
100A

4MBI75T-060
4MBI100T-060

4

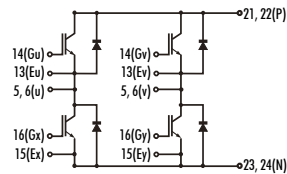
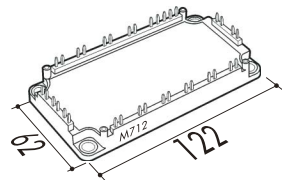

150A
200A

4MBI150T-060
4MBI200T-060

Standard

IGBT 6-pack

		600V		1200V		1700V
		Gen. 5 Planar-NPT	Gen. 6 Trench-FS	Gen. 5 Trench-FS	Gen. 6 Trench-FS	Gen. 5 Trench-FS
With NTC	5			6MBI35U4A-120		
				6MBI50U4A-120	6MBI50VA-120-50 *	
		6MBI75U2A-060	6MBI75VA-060-50 *	6MBI75U4A-120	6MBI75VA-120-50 *	
			6MBI100VA-060-50 *		6MBI100VA-120-50 *	
With NTC	6			6MBI75U4B-120		
		6MBI100U2B-060		6MBI100U4B-120	6MBI100VB-120-50 *	6MBI100U4B-170
		6MBI150U2B-060	6MBI150VB-060-50 *	6MBI150U4B-120	6MBI150VB-120-50 *	6MBI150U4B-170
					6MBI180VB-120-50 *	
With NTC	7				6MBI50VW-120-50 *	
			6MBI75VW-060-50 *		6MBI75VW-120-50 *	
			6MBI100VW-060-50 *		6MBI100VW-120-50 *	
With NTC	8				6MBI100VX-120-50 *	
			6MBI150VX-060-50 *		6MBI150VX-120-50 *	
					6MBI180VX-120-50 *	
With shunts	9			6MBI75UC-120		
				6MBI100UC-120		

* Under development

IGBT 6-pack

mm

Ic

1200V

1700V

**Gen. 5
Trench-FS**

**Gen. 5
Trench-FS**

225A

6MBI225U4-120

6MBI225U4-170

300A

6MBI300U4-120

6MBI300U4-170

450A

6MBI450U4-120

6MBI450U4-170

High power 6-pack

10

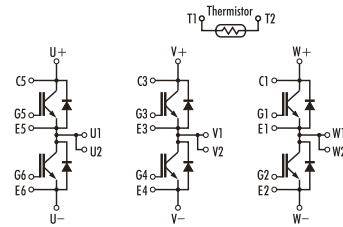
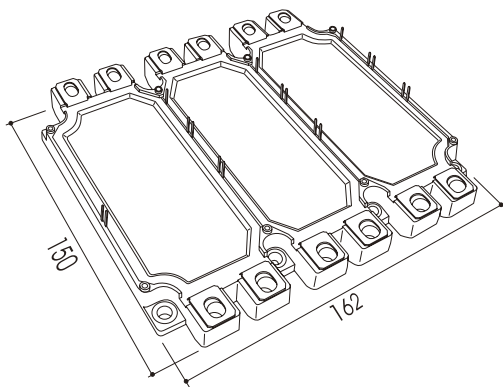

IGBT PIM (Power Integrated Module) mm

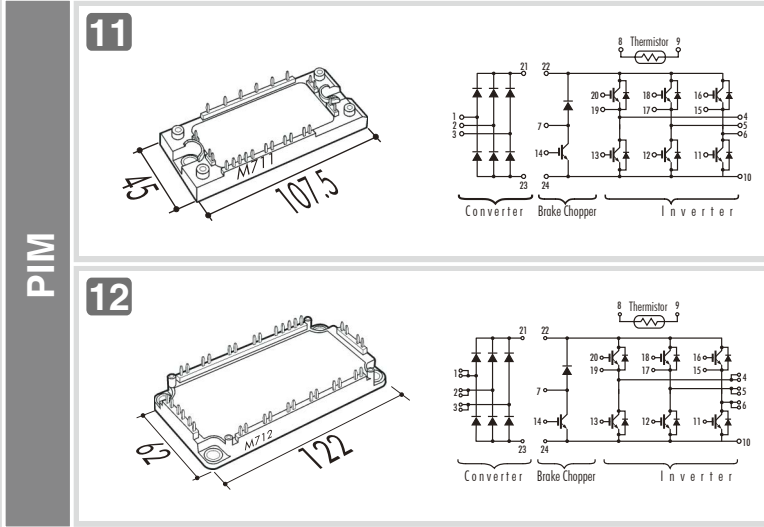

Ic	600V		1200V	
	Gen. 4 Planar-PT	Gen. 5 Trench/ Planar-NPT	Gen. 4 Planar-NPT	Gen. 5 Trench-FS
10A			7MBR10SA120	
15A			7MBR15SA120	
25A			7MBR25SA120	7MBR25UA120
30A	7MBR30SA060	7MBR30U2A060		
35A				7MBR35UA120
50A	7MBR50SA060	7MBR50U2A060		7MBR50UA120
35A			7MBR35SB120	7MBR35UB120
50A	7MBR50SB060		7MBR50SB120	7MBR50UB120
75A	7MBR75SB060	7MBR75U2B060		7MBR75U4B120
100A	7MBR100SB060	7MBR100U2B060		7MBR100U4B120

IGBT PIM (Power Integrated Module) mm

PIM

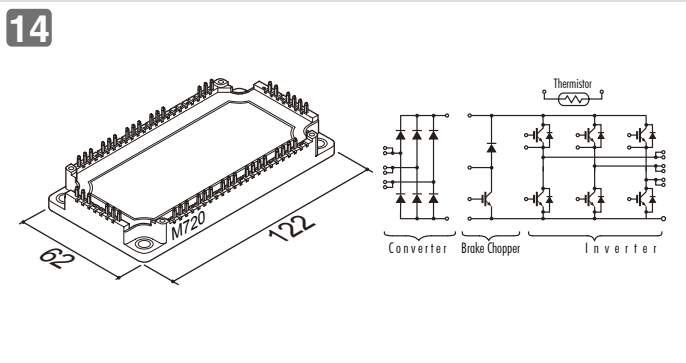
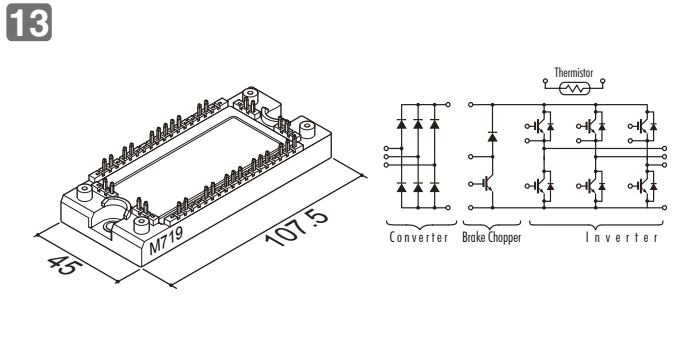

Ic

25A

35A

50A

75A

100A

50A

75A

100A

150A

600V

**Gen. 6
Trench-FS**

7MBR50VP060-50 *

7MBR75VP060-50 *

7MBR100VP060-50 *

7MBR100VR060-50 *

7MBR150VR060-50 *

1200V

**Gen. 6
Trench-FS**

7MBR25VM120-50 *
7MBR25VP120-50 *

7MBR35VM120-50 *
7MBR35VP120-50 *

7MBR50VM120-50 *
7MBR50VP120-50 *

7MBR50VN120-50 *
7MBR50VR120-50 *

7MBR75VN120-50 *
7MBR75VR120-50 *

7MBR100VN120-50 *
7MBR100VR120-50 *

7MBR150VN120-50 *
7MBR150VR120-50 *

* Under development

In/Out terminal Layout

7MBR□VM/VN□-50

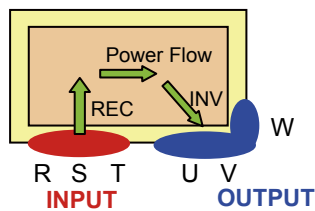

7MBR□VP/VR□-50

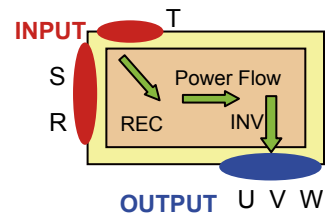

IGBT PIM (Power Integrated Module) mm

PIM

15

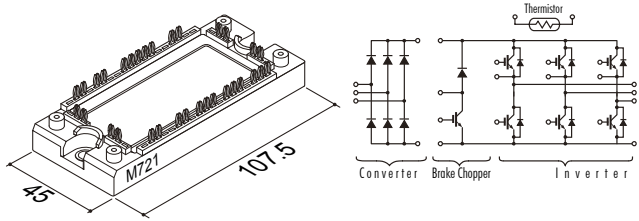

16

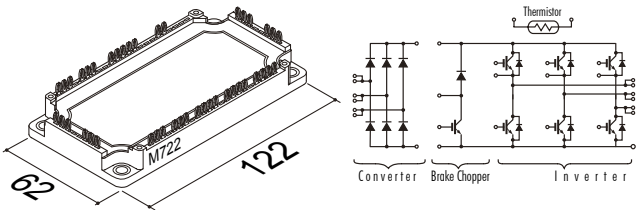

Ic

25A

35A

50A

75A

100A

50A

75A

100A

150A

600V

**Gen. 6
Trench-FS**

7MBR50VY060-50 *

7MBR75VY060-50 *

7MBR100VY060-50 *

7MBR150VZ060-50 *

1200V

**Gen. 6
Trench-FS**

7MBR25VW120-50 *
7MBR25VY120-50 *

7MBR35VW120-50 *
7MBR35VY120-50 *

7MBR50VW120-50 *
7MBR50VY120-50 *

7MBR50VX120-50 *
7MBR50VZ120-50 *

7MBR75VX120-50 *
7MBR75VZ120-50 *

7MBR100VX120-50 *
7MBR100VZ120-50 *

* Under development

In/Out terminal Layout

7MBR□VW/VX□-50

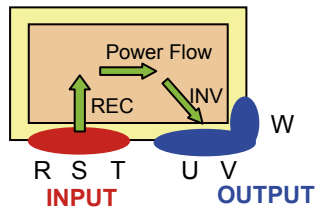

7MBR□VY/VZ□-50

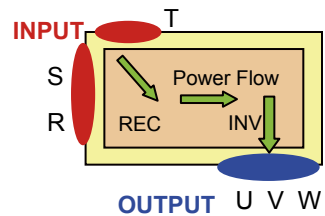

IGBT Standard 2-pack mm

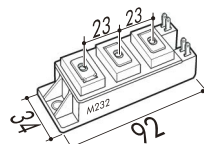
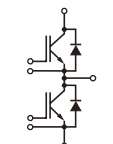
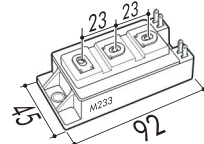
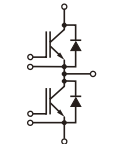
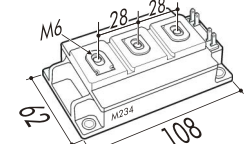
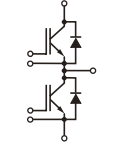
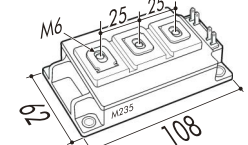
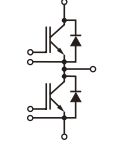
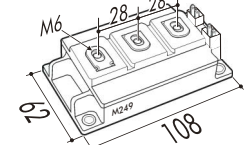
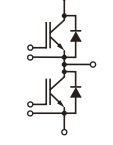
			600V	1200V		1700V	
		Ic	Gen. 5 Planar-NPT	Gen. 4 Planar-NPT	Gen. 5 Trench-FS	Gen. 5 Trench-FS	
2-pack	17  	50A					
		75A					
		100A					
		150A	2MBI150U2A-060			2MBI150U4A-120	
		200A	2MBI200U2A-060				
	18  	100A			2MBI100SC-120		
		150A			2MBI150SC-120		
		200A				2MBI150U4B-120	
		300A	2MBI300U2B-060				
		400A	2MBI400U2B-060				
	19  	100A			2MBI100S-120		
		150A			2MBI150S-120		
		200A			2MBI200S-120		
		300A				2MBI200UC-120	
		400A				2MBI300UC-120	
20  	100A						
	150A						
	200A			2MBI200SB-120			
	300A				2MBI200U4D-120		
	400A				2MBI300U4D-120		
21  	100A					2MBI100U4H-170	
	150A				2MBI150U4H-120	2MBI150U4H-170	
	200A				2MBI200U4H-120	2MBI200U4H-170	
	300A				2MBI300U4H-120	2MBI300U4H-170	
	400A				2MBI400U4H-120	2MBI400U4H-170	

IGBT Standard 2-pack mm

			600V	1200V		1700V	
		Ic	Gen. 5 Planar-NPT	Gen. 4 Planar-NPT	Gen. 5 Trench-FS	Gen. 6 Trench-FS	Gen. 5 Trench-FS
2-pack	22 	225A			2MBI225U4N-120-50	2MBI225VN-120-50 *	2MBI225U4N-170-50
		300A			2MBI300U4N-120-50	2MBI300VN-120-50 *	2MBI300U4N-170-50
		450A			2MBI450U4N-120-50	2MBI450VN-120-50 *	2MBI450U4N-170-50
		600A				2MBI600VN-120-50 *	
	23 	225A			2MBI225U4J-120-50	2MBI225VJ-120-50 *	
		300A			2MBI300U4J-120-50	2MBI300VJ-120-50 *	
		450A			2MBI450U4J-120-50	2MBI450VJ-120-50 *	
		600A				2MBI600VJ-120-50 *	
	24 	300A		2MBI300S-120	2MBI300U4E-120		
		450A			2MBI450U4E-120		
		600A	2MBI600U2E-060				
	25 	600A			2MBI600U4G-120		2MBI600U4G-170
800A				2MBI800U4G-120		2MBI800U4G-170	
1200A				2MBI1200U4G-120		2MBI1200U4G-170	

* Under development

IGBT Standard 1-pack mm

1-pack

26

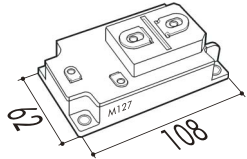

200A
300A
400A
600A

1MBI200S-120
1MBI300S-120
1MBI400S-120

1MBI300U4-120
1MBI400U4-120
1MBI600U4-120

27

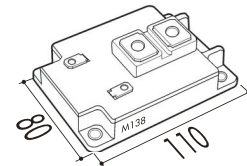

600A
800A

1MBI600S-120

1MBI600U4B-120
1MBI800U4B-120

28

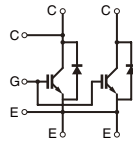
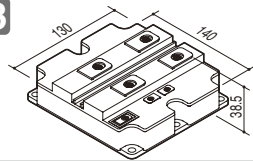

1200A
1600A

1MBI1200U4C-120
1MBI1600U4C-120

1MBI1200U4C-170
1MBI1600U4C-170

29

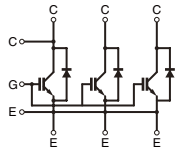
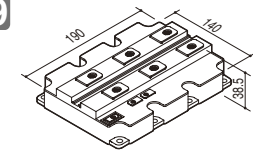

2400A
3600A

1MBI2400U4D-120
1MBI3600U4D-120

1MBI2400U4D-170
1MBI3600U4D-170

		1200V		1700V
		Gen. 4	Gen. 5	Gen. 5
		Planar-NPT	Trench-FS	Trench-FS
26	200A	1MBI200S-120		
	300A	1MBI300S-120	1MBI300U4-120	
	400A	1MBI400S-120	1MBI400U4-120	
	600A		1MBI600U4-120	
27	600A	1MBI600S-120	1MBI600U4B-120	
	800A		1MBI800U4B-120	
28	1200A		1MBI1200U4C-120	1MBI1200U4C-170
	1600A		1MBI1600U4C-120	1MBI1600U4C-170
29	2400A		1MBI2400U4D-120	1MBI2400U4D-170
	3600A		1MBI3600U4D-120	1MBI3600U4D-170

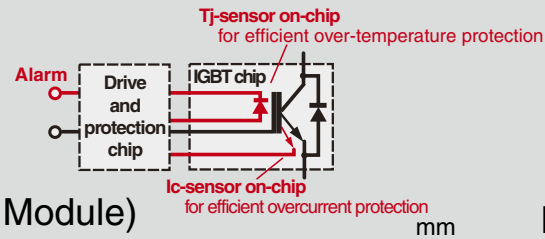

IGBT IPM (Intelligent Power Module)

	30 31	
Without brake-chopper		
With brake-chopper		
Without brake-chopper		
With brake-chopper		
Without brake-chopper		
With brake-chopper		

Ic	600V		1200V	
	Gen. 3 Planar-PT	Gen. 4 Planar-NPT	Gen. 4 Planar-NPT	Gen. 5 Planar-FS
15A	6MBP15RH060		6MBP15RA120 *	
20A	6MBP20RH060	6MBP20RTA060*		
30A	6MBP30RH060			
25A			7MBP25RSB120	
25A			6MBP25RA120	6MBP25RU2A120
50A	6MBP50RA060	6MBP50RTB060	6MBP50RA120	6MBP50RU2A120
75A	6MBP75RA060	6MBP75RTB060	6MBP75RA120	6MBP75RU2A120
100A	6MBP100RA060	6MBP100RTB060		
150A	6MBP150RA060	6MBP150RTB060		
25A			7MBP25RA120	7MBP25RU2A120
50A	7MBP50RA060	7MBP50RTB060	7MBP50RA120	7MBP50RU2A120
75A	7MBP75RA060	7MBP75RTB060	7MBP75RA120	7MBP75RU2A120
100A	7MBP100RA060	7MBP100RTB060		
150A	7MBP150RA060	7MBP150RTB060		
100A			6MBP100RA120	
150A			6MBP150RA120	
200A	6MBP200RA060			
300A	6MBP300RA060			
100A			7MBP100RA120	
150A			7MBP150RA120	
200A	7MBP200RA060			
300A	7MBP300RA060			

* The package outline is 31.

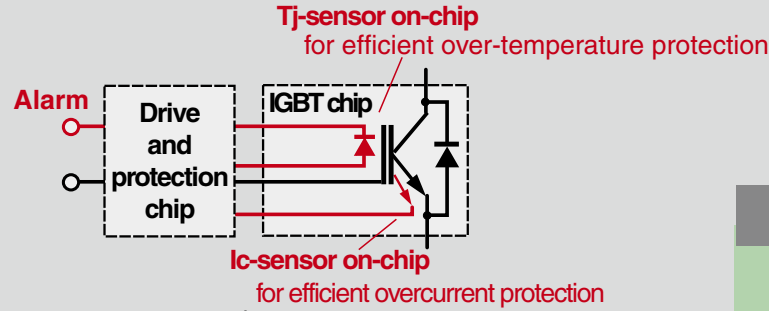

IGBT IPM (Intelligent Power Module)





mm

	35 With upper alarm output	36 With upper alarm output
Without brake-chopper		
With brake-chopper		

Ic	600V	1200V
	Gen. 4 Planar-NPT	Gen. 4 Planar-NPT
25A		6MBP25RJ120
50A	6MBP50RTJ060	6MBP50RJ120
75A	6MBP75RTJ060	6MBP75RJ120
100A	6MBP100RTJ060	
150A	6MBP150RTJ060	
25A		7MBP25RJ120
50A	7MBP50RTJ060	7MBP50RJ120
75A	7MBP75RTJ060	7MBP75RJ120
100A	7MBP100RTJ060	
150A	7MBP150RTJ060	
25A		6MBP25TEA120
50A	6MBP50TEA060	6MBP50TEA120
75A	6MBP75TEA060	6MBP75TEA120
100A	6MBP100TEA060	
150A	6MBP150TEA060	
25A		7MBP25TEA120
50A	7MBP50TEA060	7MBP50TEA120
75A	7MBP75TEA060	7MBP75TEA120
100A	7MBP100TEA060	
150A	7MBP150TEA060	

IGBT Discretes

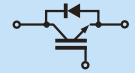
mm

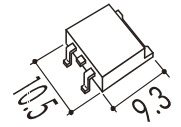
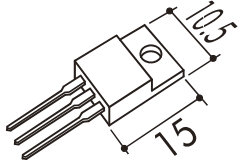
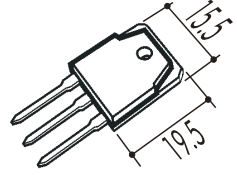
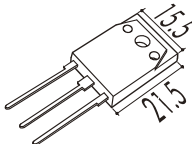
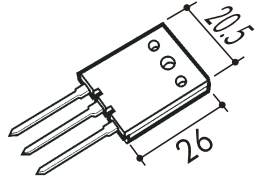
		600V		1200V	
		Planar-PT		Planar-PT	
					
Package	Part Number	IC	IC	IC	IC
T-pack(S)	37 	5A	1MBG05D-060		
		10A	1MBG10D-060		
TO-220AB	38 	2.5A			1MBC03-120
		5A	1MBC05D-060	1MBC05-060	
		10A	1MBC10D-060	1MBC10-060	
		15A		1MBC15-060	
TO-3P	39 	2.5A			1MB03D-120
		5A			1MB05D-120
		8A			1MB08D-120
		10A			1MB10D-120
		15A	1MB15D-060		
		20A	1MB20D-060	1MB20-060	
		30A		1MB30-060	
TO-247	40 	30A	1MBK30D-060S		
		50A	1MBK50D-060S		
TO-3PL	41 	15A			1MBH15D-120
		25A			1MBH25D-120
		30A	1MBH30D-060		
		50A	1MBH50D-060	1MBH50-060	
		75A	1MBH75D-060S		

Package Outlines

mm

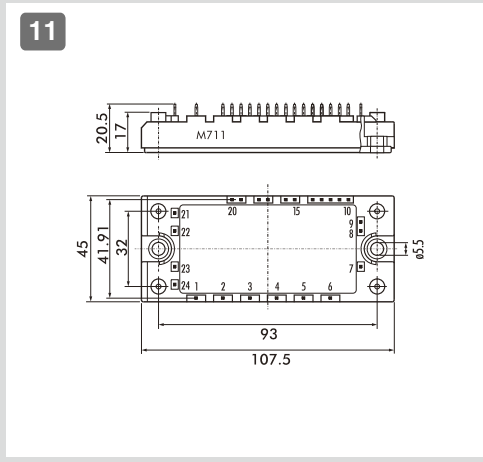
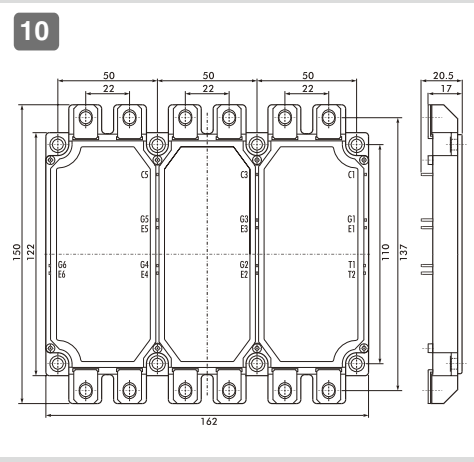
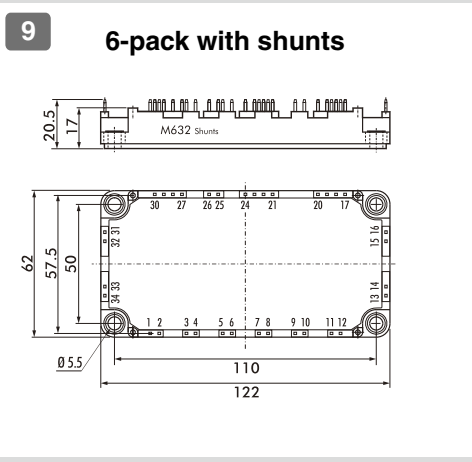
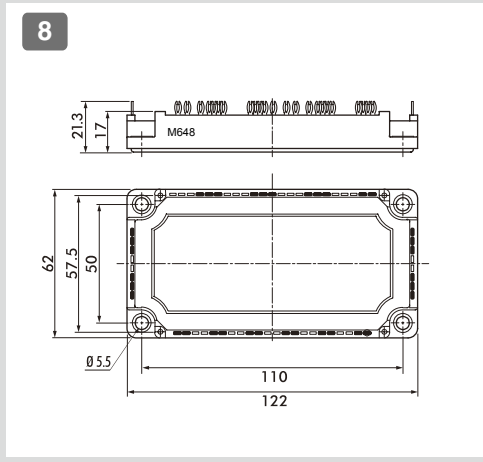
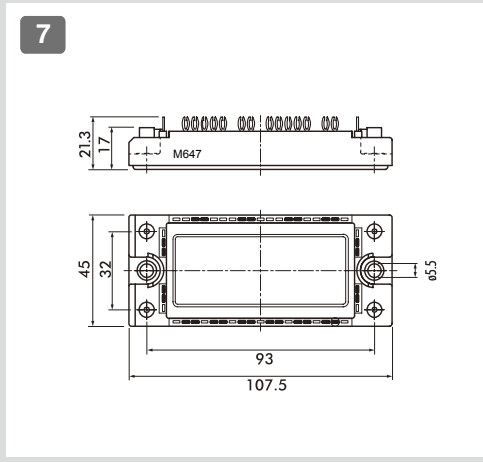
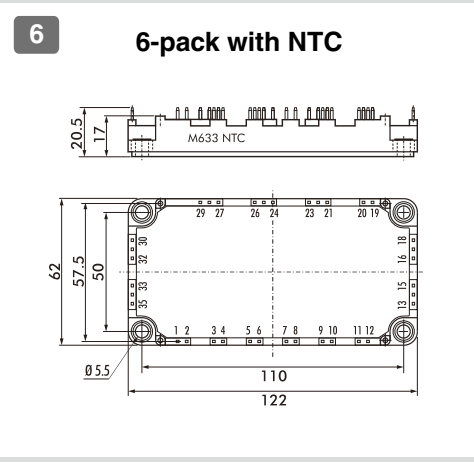
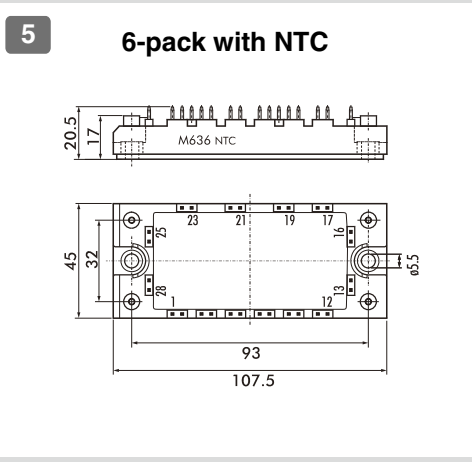
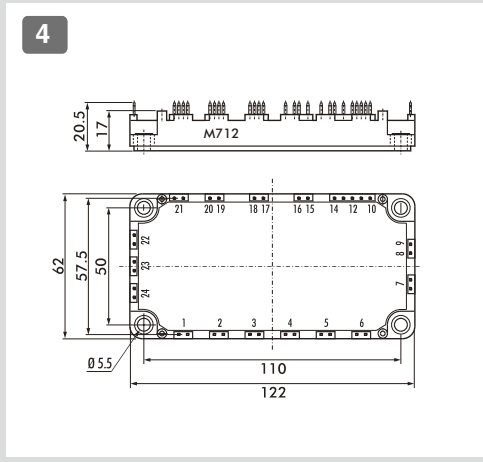
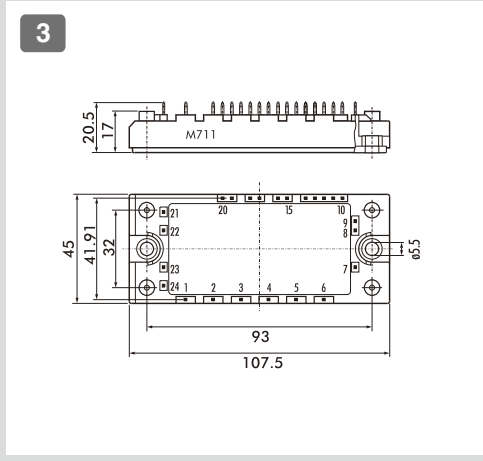
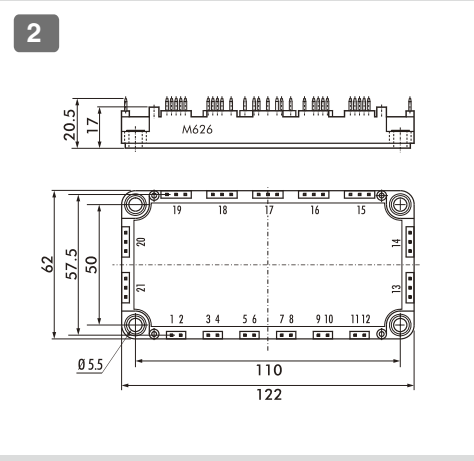
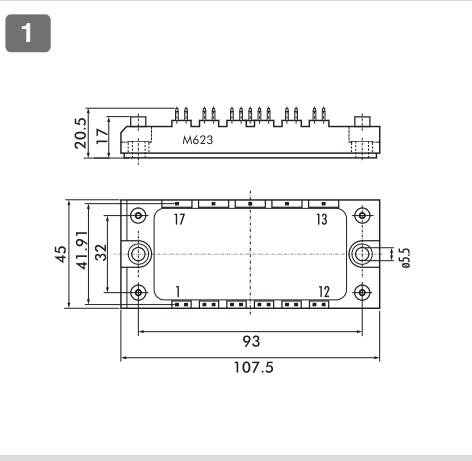

Package Outlines

mm

12

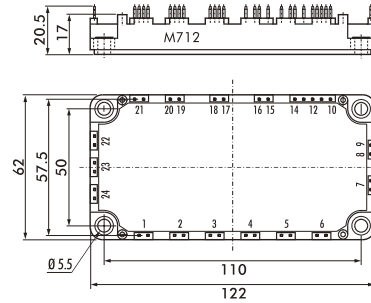

13

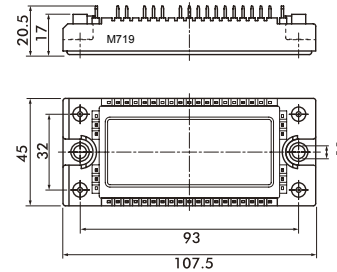

14

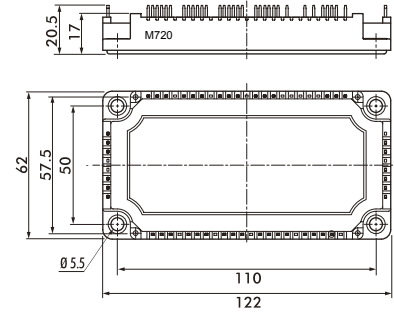

15

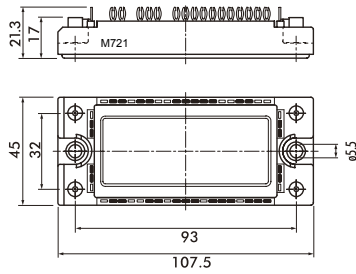

16

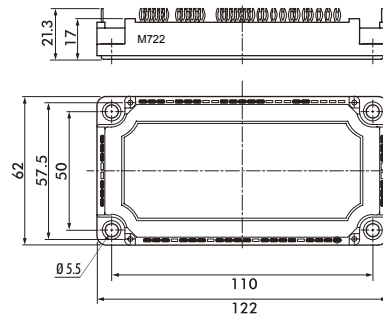

17

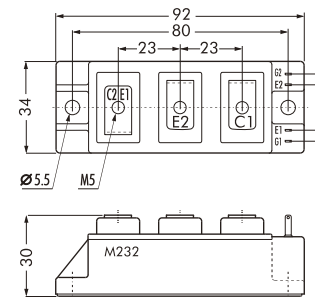

18

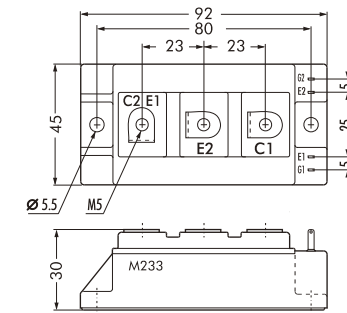

19

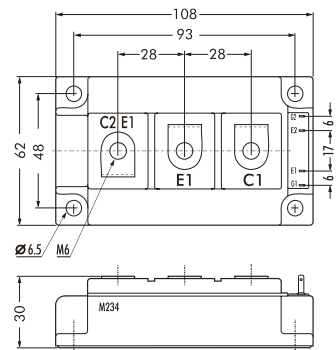

20

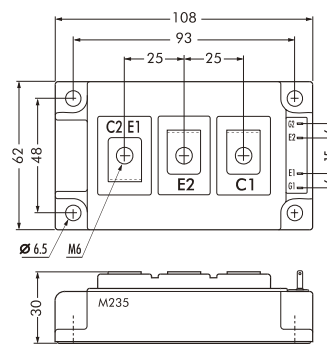

21

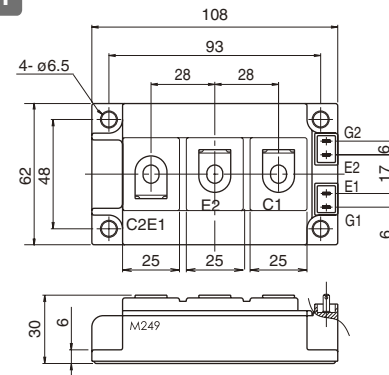

22

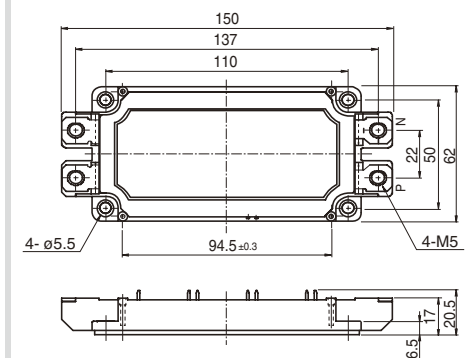

Package Outlines

mm

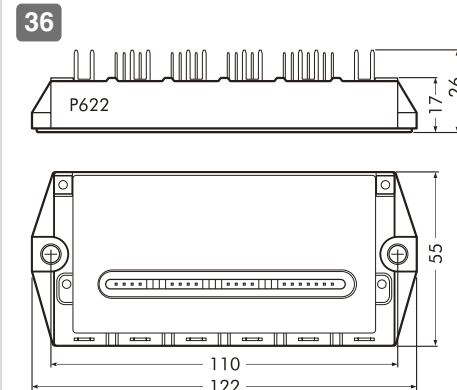
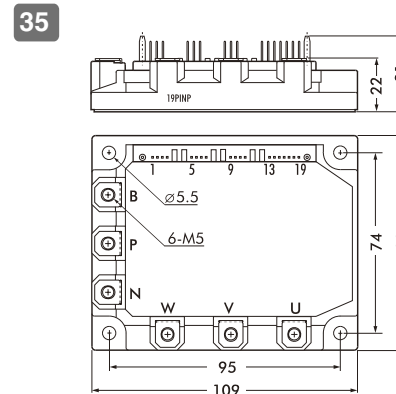
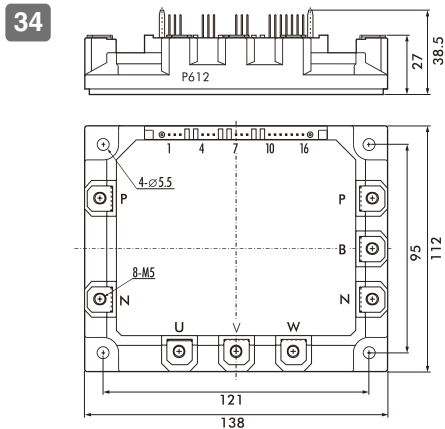

37 T-pack (S)

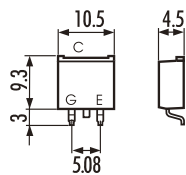

38 TO-220AB

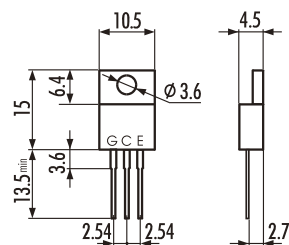

39 TO-3P

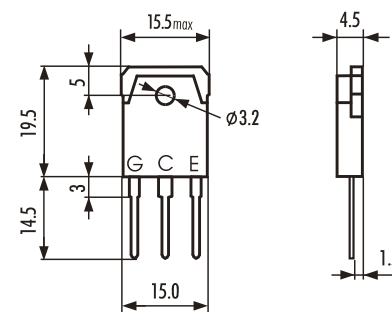

40 TO-247

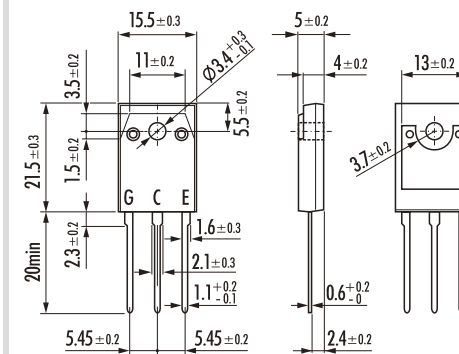

41 TO-3PL

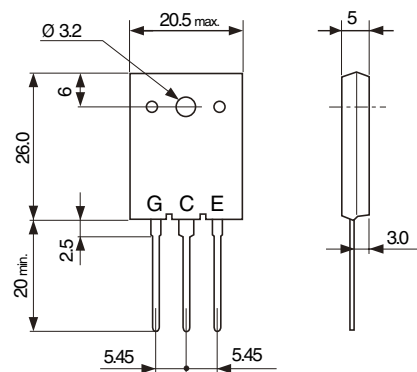

富士電機デバイステクノロジー株式会社

半導体事業本部

<http://www.fujielectric.co.jp/fdt/scd/index.html>

東日本支社

〒141-0032 東京都品川区大崎一丁目11番2号（ゲートシティ大崎イーストタワー）

TEL: 03-5435-7161

中部支社

〒460-0003 名古屋市中区錦一丁目19番24号（名古屋第一ビル）

TEL: 052-204-0295

西日本支社

〒530-0004 大阪市北区堂島浜二丁目1番29号（古河大阪ビル）

TEL: 06-6341-6510