

ZONE	REV	DESCRIPTION	ECN #	CHG BY	DATE	APP'D

REVISONS	ECN #	CHG BY	DATE	APP'D

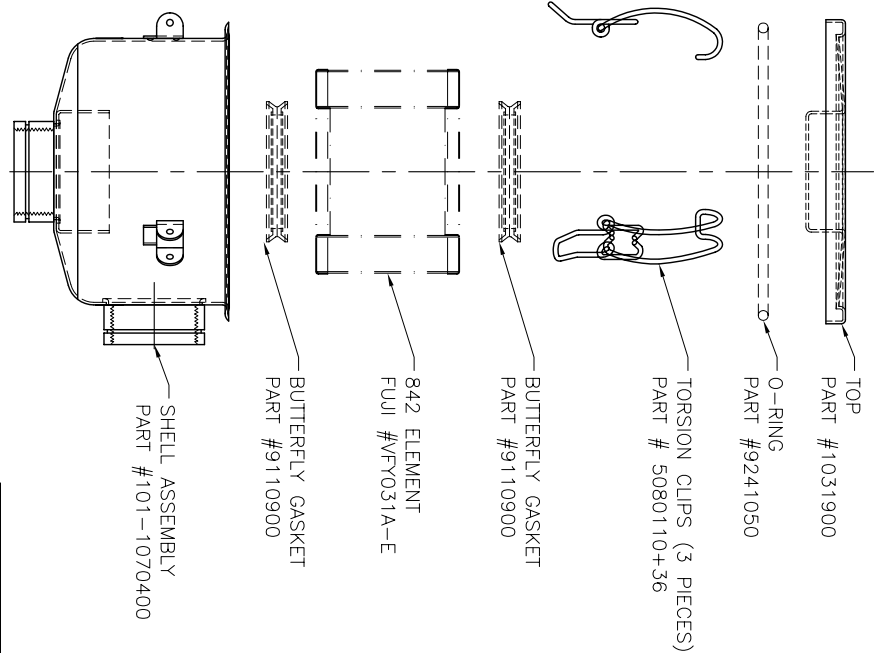
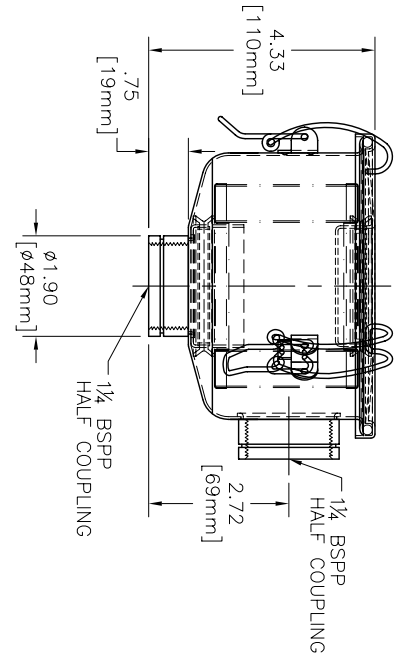
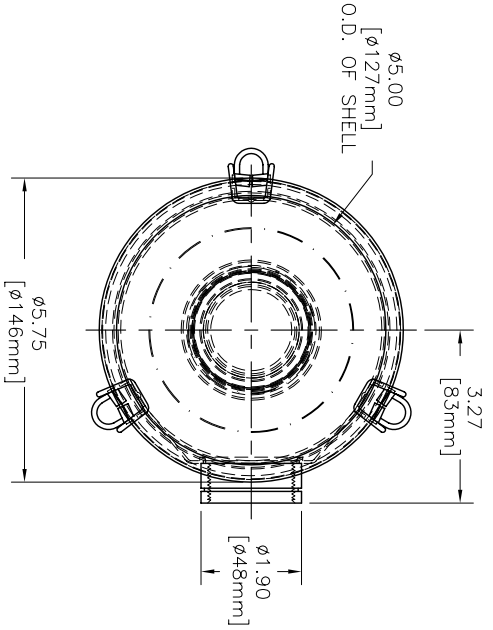

MODEL #	HOUSING MATERIAL	FINISH
VFT031A	CARBON STEEL	BAKED ENAMEL GREY

**NOTE: DIMENSIONS TO MATCH FUJI 1994 DRAWINGS.

The information contained herein is confidential and the information is provided to you with the expressed understanding that it will not be disclosed to others outside of the part, nor used for any other purpose without the express written consent of Solberg Manufacturing Inc. The information is provided to you for your information only. The information is not to be used for any other purpose, and any other restrictions which may apply to this information are hereby acknowledged. Solberg Manufacturing Inc. reserves the right to change this information without notice and without obligation to provide any explanation or justification over any presentation that may be necessary to uphold these restrictions.

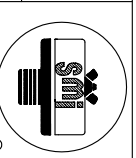

SOLEBERG MANUFACTURING INC.
1151 W. ARDMORE AVE.
ITASCA, IL 60143
630/773-1363
DESCRIPTION:
FUJI PART #VFY031A

UNLESS OTHERWISE SPECIFIED:
DIMENSIONS ARE IN MILLIMETERS
-TOLERANCES ARE:
DECIMALS: XX ±.25
XXX ±.125
ANGLES: ±2°

SALES REP.: E. NISTROW
APPROVALS: DATE: 01/05/00
DRAWN: P.E. APPROVED: JMB 01/10/00
SHEET: 1 OF 1 SHEET SCALE: 1:1
DRAWING NUMBER: SD11931
REV: —

